

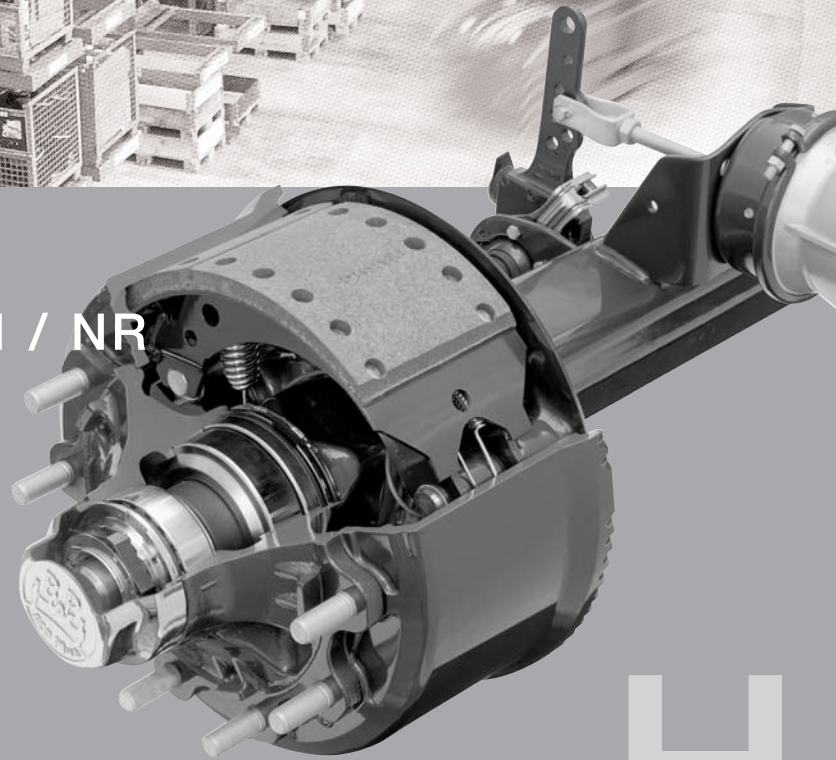

BPW Original spare parts  
Series H / R; KH / KR; NH / NR



H

K

BPW ORIGINAL SPARE PARTS

N

Contents		Page		
		Axle series		
		H.. / R.. Ø 420	KH.. / KR.. Ø 360	NH.. / NR.. Ø 300
	Explanation of BPW axle type codes	4	4	4
	Explanation of BPW axle code numbers	5	5	5
<b>1</b>	<b>Axle beams</b>	<b>6 - 9</b>	<b>6 - 9</b>	<b>6 - 9</b>
1.1	Axle beam, booster brackets	8 - 9	8 - 9	8 - 9
<b>2</b>	<b>Brake camshafts, brake camshaft bearings</b>	<b>10 - 19</b>	<b>10 - 19</b>	<b>10 - 19</b>
2.1	Brake camshafts	12	12	13
2.2	Brake camshaft bearings	14 - 19	14 - 19	14 - 19
<b>3</b>	<b>Slack adjusters</b>	<b>20 - 49</b>	<b>30 - 49</b>	<b>30 - 49</b>
3.1	Manual slack adjusters type GSK, return springs	22	22	22
3.2	Automatic slack adjusters type ECO-Master	23 / 24	23 / 25	23 / 26
3.3	Installation instructions ECO-Master	27	27	27
3.4	Slack adjuster attachments	28 - 29	28 - 29	28 - 29
<b>4</b>	<b>Brake parts</b>	<b>30 - 49</b>	<b>30 - 49</b>	<b>30 - 49</b>
4.1	Brake parts SN ....-2, retrofit kits	32 - 33	34 - 35	36 - 37
4.2	Brake parts for brake BPW 95	38 - 39	40 - 41	42 - 43
4.3	Brake drums	44	45	45
4.4	Brake drum attachments	46	46	47
4.5	Dust covers	48	49	49
4.6	Brake cylinder	50 - 51	50 - 51	50 - 51
<b>5</b>	<b>Hub bearings, hub seals</b>	<b>52 - 68</b>	<b>52 - 68</b>	<b>52 - 67</b>
5.1	Hub bearings, hub seals, conventional hub bearing system	54 - 57	54 - 57	58 - 59
5.2	Hub bearings, hub seals, ECO hub system	60 - 61	60 - 61	60 - 61
5.3	Hub bearings, hub seals, ECO <sup>Plus</sup> hub system	62 - 63	62 - 63	-
5.4	Hubs, conventional hub bearing system	64	64	64
5.5	Hubs, ECO hub system	65	65	66
5.6	Hubs, ECO <sup>Plus</sup> hub system	67	67	-
5.7	Grease filling, bearing adjustment, conventional	68	68	68
5.8	Grease filling, bearing adjustment, ECO	69	69	69
5.9	Grease filling, bearing adjustment, ECO <sup>Plus</sup>	70	70	-
5.10	Grease sprays for greasing taper roller bearings	71	71	71
<b>6</b>	<b>ABS</b>	<b>72 - 81</b>	<b>72 - 81</b>	<b>72 - 81</b>
6.1	ABS parts	74 - 75	76 - 77	78 - 79
6.2	ABS retrofit part sets	80	81	81
<b>7</b>	<b>TRILEX</b>	<b>82 - 83</b>	-	-
<b>8</b>	<b>Wheel studs</b>	<b>84 - 89</b>	<b>84 - 89</b>	<b>84 - 89</b>
8.1	Wheel studs, single wheels	86 - 87	86 - 87	86 - 87
8.2	Wheel studs, twin wheels	88 - 89	88 - 89	88 - 89
<b>9</b>	<b>Hub caps with integrated Hubodometer</b>	<b>90 - 91</b>	<b>90 - 91</b>	<b>90 - 91</b>

Valid: 1.1.2005

This spare parts list shows fast moving parts for BPW trailer axles

**series H.. / K.. / N.. 6.5 - 18 tons** from 1983 (1982) onwards.

Additional spare parts as per spare parts catalogue.

 -parts are embossed with BPW Code no.

Subject to change (without notice).



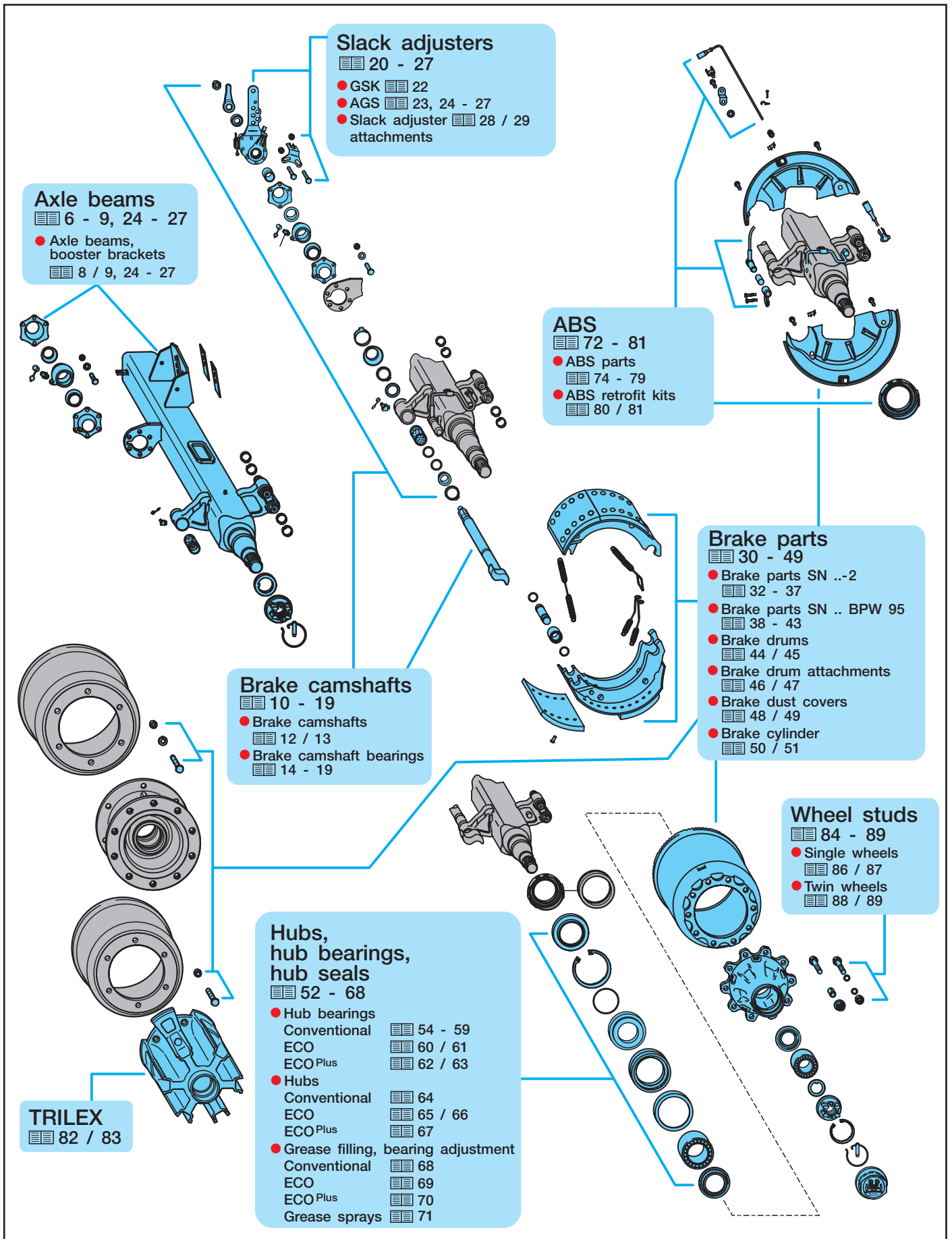

# BPW Original spare parts • Series H / R; KH / KR; NH / NR

Riveted type plate up to year of manufacture 1999

Glued type plate from year of manufacture 2000

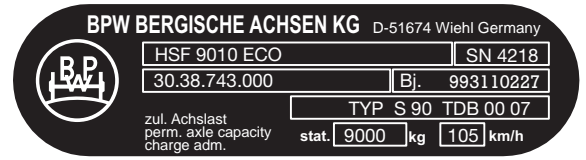
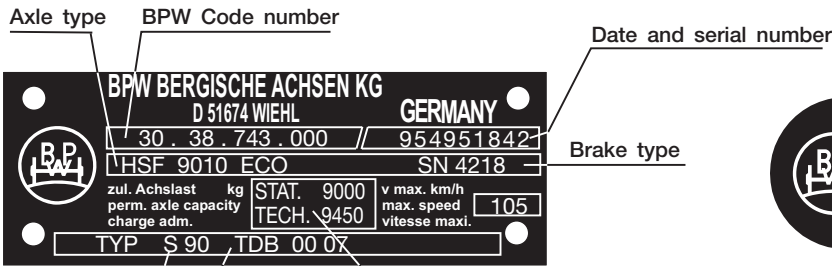

Stat. = Max. static axle load on ground  
 Tech. = "Permissible techn. axle load"  
 = Test load of wheel brakes

## Explanation of BPW axle type codes

Example:											
H	S	F	A	H	9010	-15	ECO				
								Axle series	Axle beam	Brake	Tyre
H								H..	□	SN 420	20" - 24"
R								R..	○		
KH								KH..	□	SN 360	19.5
KM								KM..	■		
KR								KR..	○		
KRD								KRD..	●		
NH								NH..	□	SN 300	15" / 17.5"
NR								NR..	○		
NRD								NRD..	●		
	B							For single wheels, wheels with offset			
	S							For single wheels, wheels without offset			
	Z							For twin wheels			
	I							Wheel spiders for TRILEX wheel rims, single wheels			
	IZ							Wheel spiders for TRILEX wheel rims, twin wheels			
		F						Wheel studs M 22 x 1.5 without wheel nuts, order wheel nuts for stud or spigot alignment separately			
		M						For spigot alignment			
			A					With alloy hubs			
				(D)				( German Dauerbremse )			
				H				For hanging boosters			
					6006 to 18010			Axle load (kg) + quantity of wheel studs per hub			
						-15		Axle beam - wall thickness, e.g. 15 mm			
						-1		Type of hub bearing (e.g. 14 t)			
						/3		Wheel connection - 10 wheel studs, pitch circle 335 mm			
							ECO	ECO hub system			
							ECO-MAXX	Weight optimized trailer axle with ECO hub system			
							ECOPlus	Weight optimized trailer axle with ECOPlus hub system			
							MAXX	Weight optimized trailer axle with helical fit wheel bolts			

## Explanation of BPW axle code numbers

Example:						
30.	38.	743.	000			
20.				<b>Trailer axle without suspension parts</b>		
24.						
25.						
27.						
30.						
31.						
				<b>Axle load</b>	<b>Roller bearing</b>	
06.				6500 kg	33116 / 32310	Conventional hub bearing system
08. 09.				8000 - 9000 kg	33116 / 32310	
10.				10000 - 12000 kg	33118 / 32313	
14.				13000 - 14000 kg	32219 / 33215	
16.				16000 - 18000 kg	32222 / 33214	
36.				6500 kg	33116 / 32310	ECO hub bearing system
38.				8000 - 9000 kg	33116 / 32310	
40.				10000 - 12000 kg	33118 / 33213	
44.				13000 - 14000 kg	32219 / 33215	ECOPlus hub bearing system
48.				8000 - 9000 kg	33118 / 33213	
50.				10000 - 12000 kg	33118 / 33213	
65.				6400 kg	33215 / 32310	Conventional hub bearing system
				<b>Wheel brake type</b>	<b>Dimension</b>	
582.				SN 3015-1 HWG closed	Ø 300 x 150	Brake shoes with closed anchor eye (old type) up to 1989
586.				SN 3020-1 HWG closed	Ø 300 x 200	
592.				SN 3015 HWG closed	Ø 300 x 150	Quick-release brake shoes from 1990 onwards
596.				SN 3020 HWG closed	Ø 300 x 200	
501.				SN 3015 BPW 95 closed	Ø 300 x 150	Brake shoes with splitted roller (BPW 95)
502.				SN 3020 BPW 95 closed	Ø 300 x 200	
542.				SN 3616 closed	Ø 360 x 160	Brake shoes with splitted roller (BPW 95)
546.				SN 3620 closed	Ø 360 x 200	
551.				SN 3616 BPW 95 closed	Ø 360 x 160	
552.				SN 3620 BPW 95 closed	Ø 360 x 200	
790.				SN 4212-2 HWG offen	Ø 420 x 120	
794.				SN 4212-2 HWG closed	Ø 420 x 120	
710.				SN 4218-2 HWG offen	Ø 420 x 180	Brake shoes with splitted roller (BPW 95)
714.				SN 4218-2 HWG closed	Ø 420 x 180	
718.				SN 4220-2 HWG offen	Ø 420 x 200	
723.				SN 4220-2 HWG closed	Ø 420 x 200	
739.				SN 4222-2 HWG closed	Ø 420 x 220	
741.				SN 4212 BPW 95 closed	Ø 420 x 120	
743.				SN 4218 BPW 95 closed	Ø 420 x 180	
744.				SN 4220 BPW 95 closed	Ø 420 x 200	
745.				SN 4222 BPW 95 closed	Ø 420 x 220	
				<b>000</b>	<b>Consecutive number 000 - 999</b>	

## 1 Axle beams, booster brackets

H

### General

#### BPW Axle beams

Square, reliable, light – the BPW axle beam. It's the stable foundation for a long vehicle life. And in combination with our brakes and suspension systems, the square axle produces axle systems which offer convincing allround performance with long service lives and maintenance intervals.

The BPW square axle beam consists of two high-quality, specially rolled axle half-tubes (U-sections) which are welded together inside and out.

The special feature of the BPW standard axle tube with a 120 mm axle cross-section is its Q.U.A.D. profile (Quality Upgraded Advanced Design). This profile features more material at the corner radii and less material in the top and bottom areas. As a result, the axle cross-sections are reinforced at the points where the force is applied and are optimally shaped to cope with the load.

The Q.U.A.D. profile ensures that the maximum service life can be achieved. BPW axle tubes are available with various cross-sections and wall thickness values depending on the axle load and the application conditions.

BPW axle stubs are forged, quenched and tempered. They have two stepped bearing seats.

The axle stubs and axle tube are flash butt-welded together to produce one piece – the BPW axle beam.

In this welding process, the axle tube and the ends of the axle stubs are heated up to welding temperature by an electric current applied at their joining faces, whilst at the same time being forced together.

This produces an absolutely homogeneous connection without any inclusions. In contrast to conventional welding processes, no filler metals are needed.

At the same time, the axle beam is given its camber and toe-in.

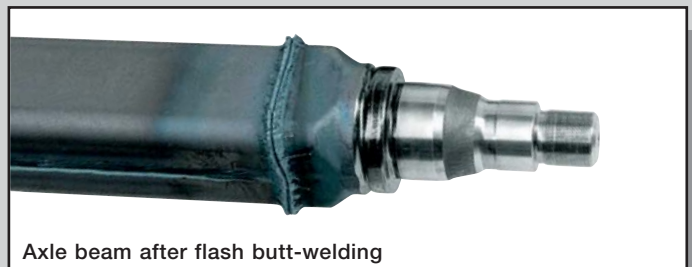
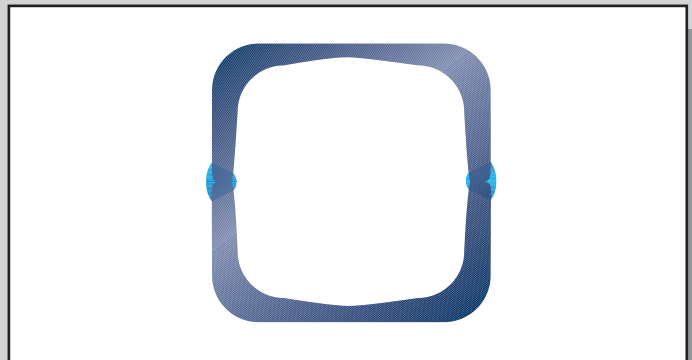
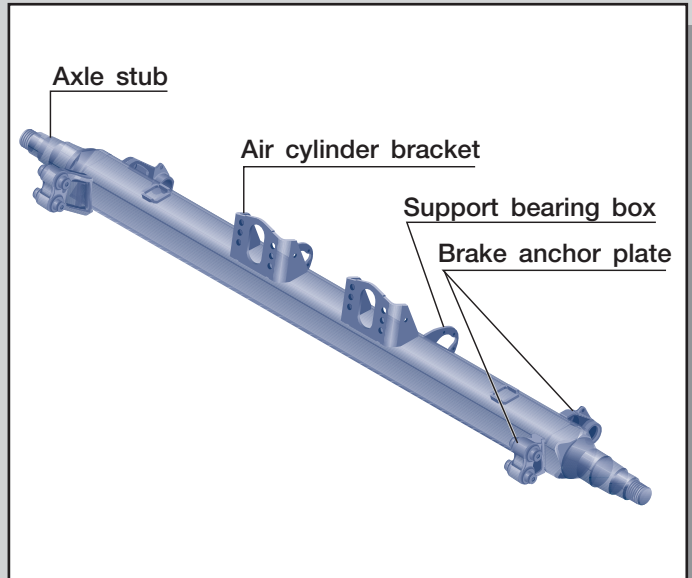

Axle beam after flash butt-welding

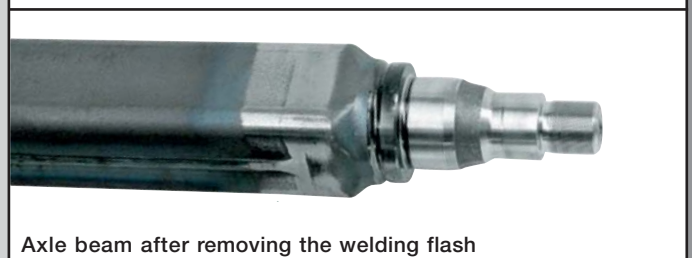

Axle beam after removing the welding flash

## Determining replacement axle beams

The BPW axle number is shown on the type plate. If this is missing or no longer legible, the BPW axle number can be read off the front end of the axle stub.

When ordering the axle beam, quote this BPW axle number with the reference to a replacement axle beam.

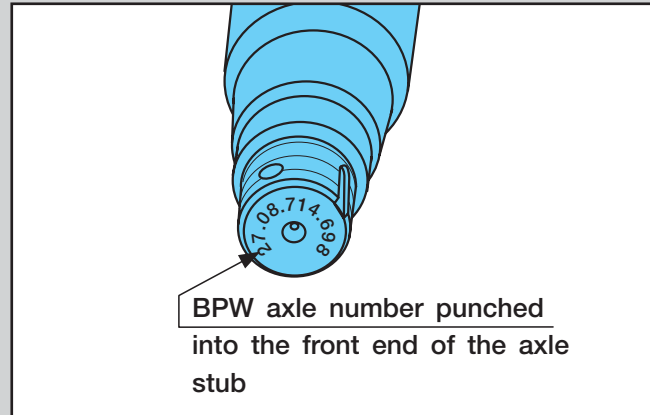

If there is no BPW axle number or none is known, the axle beam or the axle can be identified on the basis of the dimensions.

1. Axle beam cross section (□ 120 / 150, Ø 127)
2. Axle beam wall thickness
3. Booster bracket centre (GM)
4. Spring centre (FM)
5. Track (SP)
6. Overall width (P)
7. Leaf spring width (FB)
8. Spring pad hole pattern (C and D)
9. Wheel seat (H)
10. Pitch circle and number of wheel studs (K)

Furthermore, the **type of tyres**, the **brake size** and the approximate **year of manufacture** (first registration) should be specified.

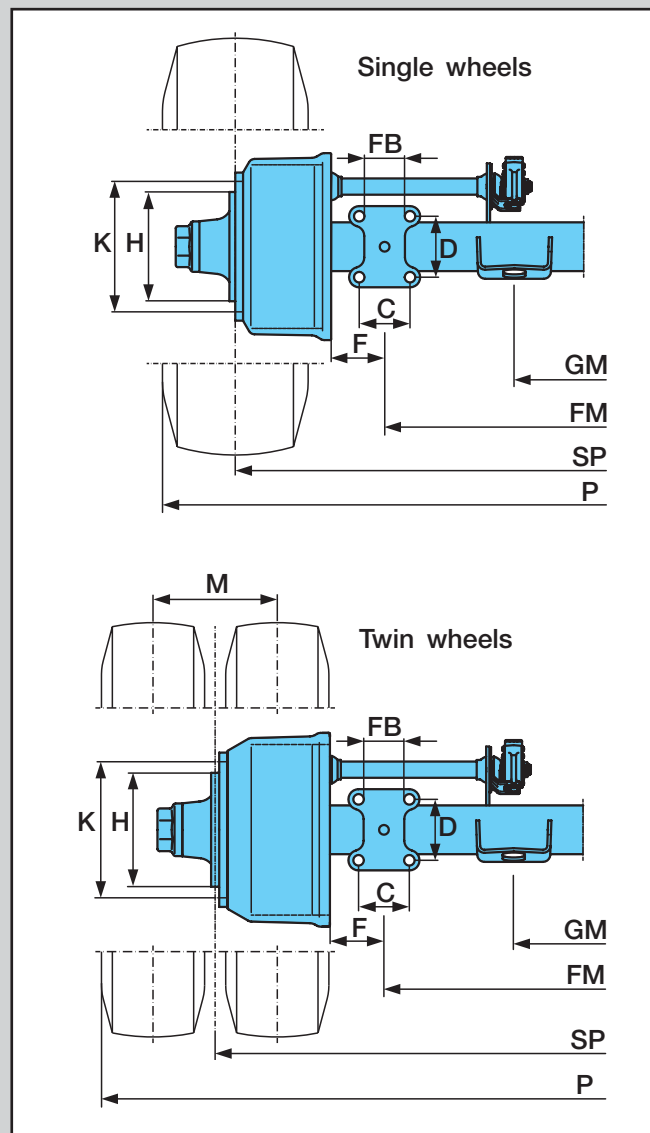

## 1 Axle beams, booster brackets

**H.. / KH.. Conv. / ECO**  
Brake ...-1 / 2

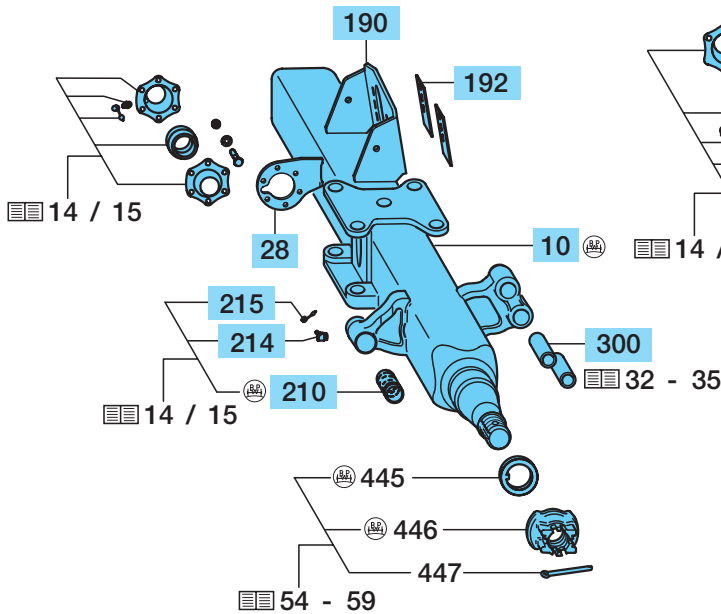

**H.. / KH.. ECO / ECO<sup>Plus</sup>**  
Brake with splitted roller (BPW 95)

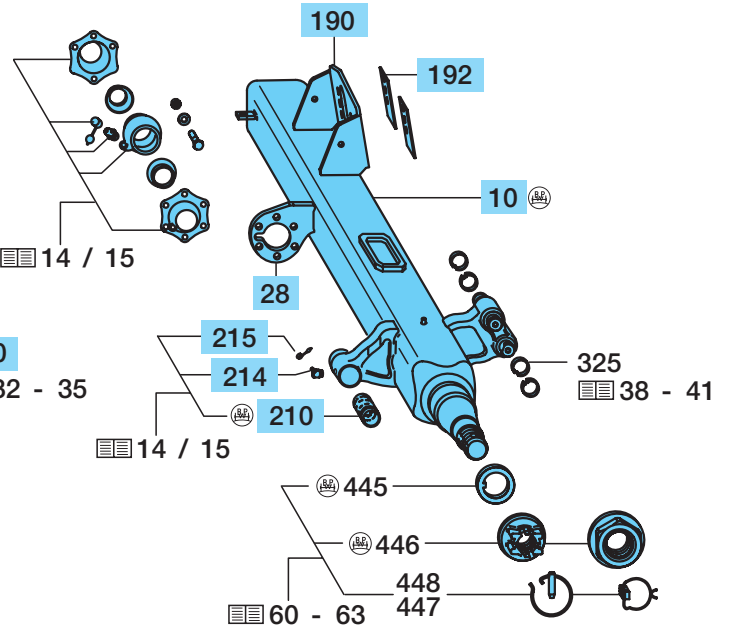

**NR.. Conv. / ECO**  
Brake ...-1 / 2

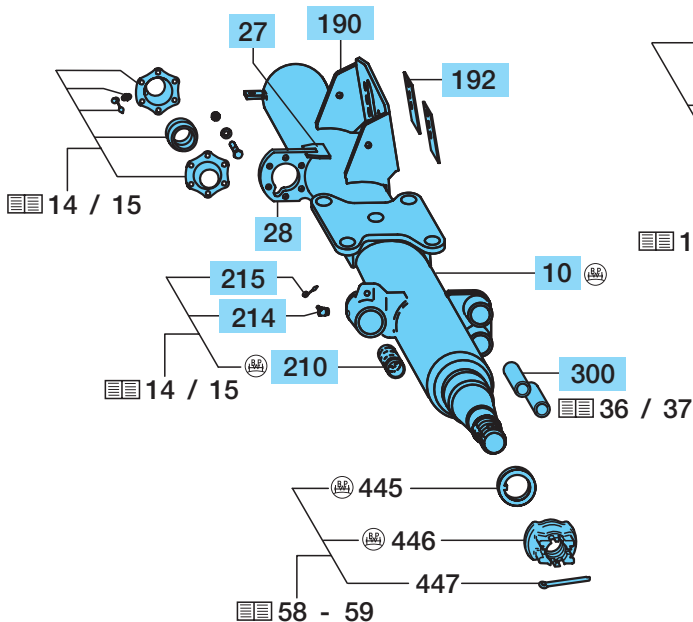

**NH.. ECO**  
Brake with splitted roller (BPW 95)

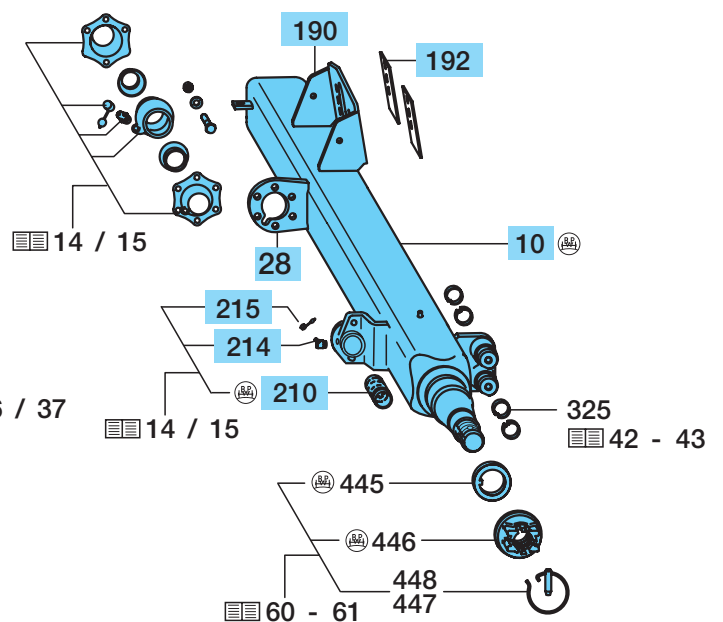

**Axle series H.. / R..**

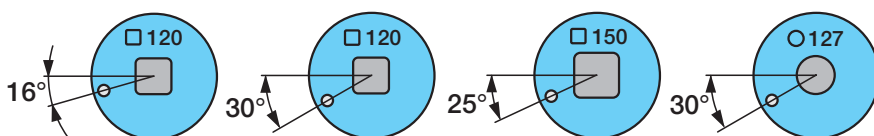

**Axle series K.. / N..**

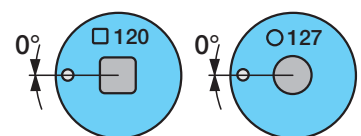



# Axle beams, booster brackets 1

H

K

N

Item	Designation (Remark)	BPW Code no. Dimension		
		H.. / R..	KH.. / KR.. / KM..	NH.. / NR..
10	Axle beam assembly (incl. item 27, 28, 190-194 210-215, 220-230, 300, 445-447)	When ordering axle beam assembly, please state axle type and BPW code-no. (Axle name plate).		
27	Plate	-	-	03.287.43.03.0 Brake 30...-1
28	Plate	03.285.55.71.0 □ 120 16° 03.285.55.22.0 □ 120 30° 03.285.55.21.0 □ 150 25° 03.285.55.23.0 ○ 127 30°	03.285.54.12.0 □ 120 03.285.56.18.0 ○ 127	03.285.54.16.0 □ 120 03.285.55.19.0 ○ 127

Booster brackets welded on				
	Designation (Remark)	BPW Code no. Dimension		
		H.. / R..	KH.. / KR.. / KM..	NH.. / NR..
190	Booster bracket (standard) <sup>1)</sup>	03.182.35.78.0 □ 120 16° 03.182.34.77.0 □ 120 30° □ 150 25° 03.182.34.58.0 ○ 127	03.182.35.42.0 □ 120 03.182.34.65.0 ○ 127 03.182.34.95.0 ○ 127 15°	03.182.35.80.0 □ 120 03.182.34.65.0 ○ 127
192	Plate (Reinforcement plate for spring brakes)	03.281.54.10.0	03.281.54.10.0	03.281.54.10.0

<sup>1)</sup> for further types refer pages 24 - 26.

Adjustable booster brackets		Adjustable booster brackets are not included with axle beam assembly 09.....		
190	Booster bracket	05.182.34.23.0		
192	Shaped plate	03.165.56.01.0 □ 120 / 150		
193	Shaped plate	03.165.56.02.0		
		03.165.56.05.0 ○ 127		
194	Screw assembly (incl. item 198, 200)	03.165.56.06.0	05.865.01.04.0 M 12 x 40/933	
198	Spring washer	02.5601.12.90 A 12 / 128		
200	Hexagon nut	02.5202.16.80 M 12 / 934		

Item	Designation (Remark)	BPW Code no. Dimension		
		H.. / R..	KH.. / KR.. / KM..	NH.. / NR..
210	Bush	03.112.44.34.0	Ø 42/46x73	03.112.44.34.0 Ø 42/46x73
214	Grease nipple e.g. SN 4222	<b>02.6802.03.50</b> AM 10 x 1 02.6802.06.50 BM 10 x 1 02.6850.12.50 BM 10 x 1/67°		<b>02.6802.03.50</b> AM 10 x 1 02.6802.06.50 BM 10 x 1 -
215	Cap	02.3505.20.00		02.3505.20.00
300	Bush (for brake ...-1 / -2)	03.112.33.08.0	Ø 36/40x60	03.112.33.08.0 Ø 36/40x60

## 2 Brake camshafts and brake camshaft bearings

### General

#### BPW Brake camshafts and bearings

Optimized sealing and improved support for brake camshaft bearings on BPW drum brake axles

As from October 2000, an innovative sintered bush in conjunction with a new integrated sealing system will mean double life expectancy for bearing and brake camshaft units.

#### Advantages:

- Double life expectancy for brake camshaft and bearing units
- Increased reliability of operation
- Integrated sealing system
- Compact design
- Easy, secure installation
- For use with all BPW drum brake axles

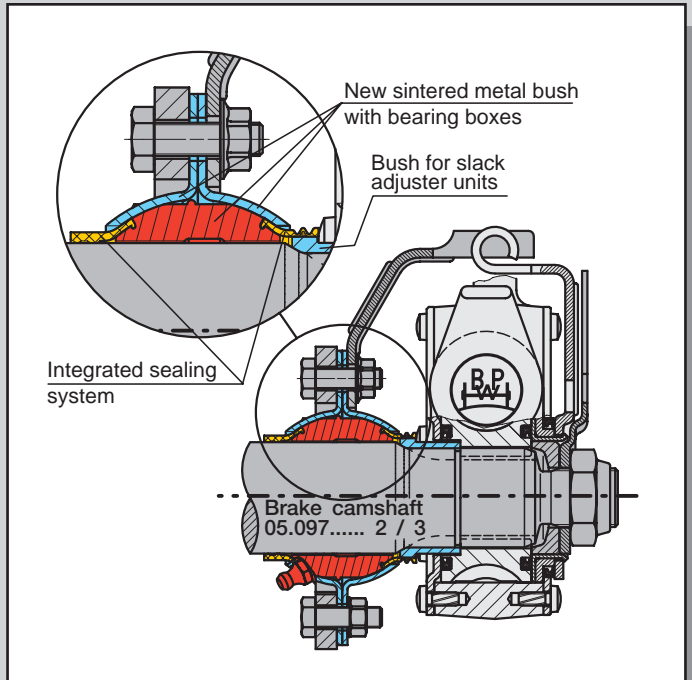

#### Slack adjuster system on the brake camshaft

- 4 / 91

Contact on collar of brake camshaft ( 1 )

5 / 91 - 10 / 00

Contact on circlip ( 2 )

10 / 00 -

Contact on the bush pushed onto the brake camshaft ( 3 )

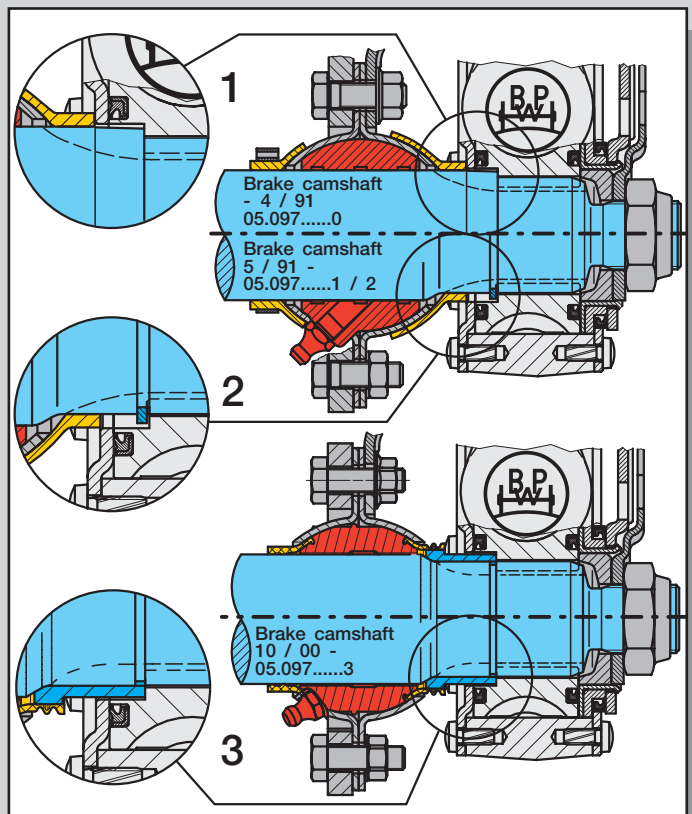

## Optimized brake camshaft bush and additional 'O'-Ring

From February 2002, BPW drum brake axles with support bearings for brake sizes SN 300, SN 360, and SN 420 will be fitted with a further development of our camshaft bearing on the brake anchor plate side.

### Features:

- The layout of the lubricating grooves inside the brass bush 03.112.44.34.0 has been improved. The bush has a machined annular groove on the outside. The previous code number for the bush will apply.
- The brake camshaft has an additional groove in the bearing seat on the cam side in order to accommodate the 'O'-ring 02.5677.37.42 (Ø 37 x 2.6 (black)). The code number of the brake camshaft has changed. The last digit of the former number ( 1 or 2 ) is changed to indicate version 3.

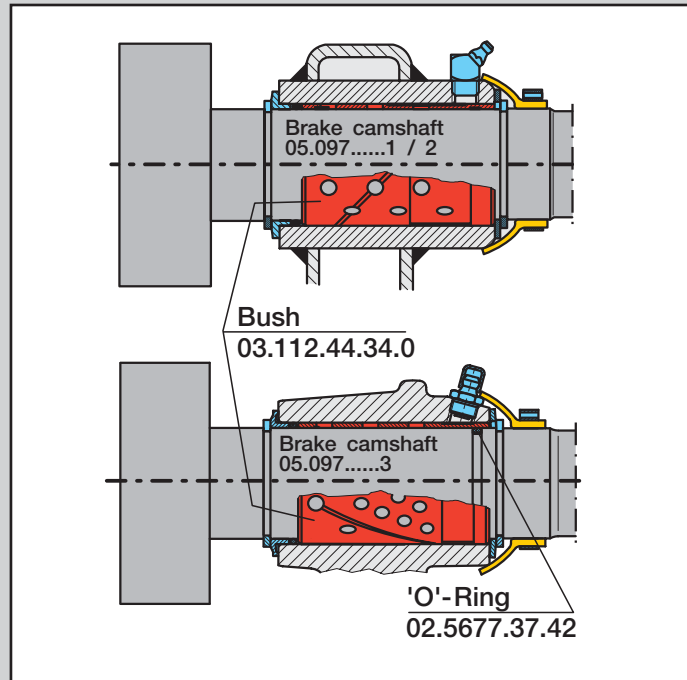

## Modified inner camshaft support bearing fixing screws on drum brake axles !

From week 23/2003 onwards, the inner camshaft support bearing fixing screws will be modified on series production drum brake axles. The self-tapping screws 02.5071.23.00 used as standard up to now will be replaced by hexagon screws 02.5025.30.82 with nuts.

In automatic slack adjusters (AGS), the shaped plate for the slack adjuster support is secured using these bolts in conjunction with the Tensilock lock nuts (BPW no. 02.5273.32.82).

The other screw connection of the support bearing is made with the bolts in connection with spring washers and normal hexagon nuts (BPW no. cpl. 05.865.00.02.0).

The screws are fitted towards the centre of the axle.

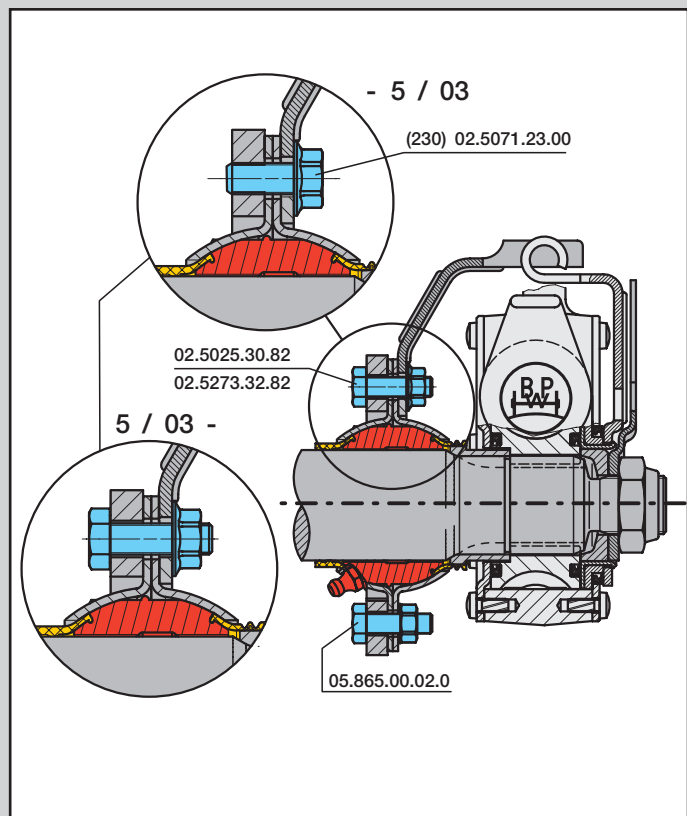

## 2.1 Brake camshafts

Item	Designation (Remark)	BPW Code no.	
240	Brake camshaft, left	05.097.....3	
241	Brake camshaft, right	05.097.....3	
<b>H.. / R..</b>		<b>SN 42..</b>	<b>---.7xx---</b>
<b>KH.. / KR..</b>		<b>SN 3620</b>	<b>---.546. / 552---</b>
<b>A</b>	<b>L</b>	<b>left</b>	<b>right</b>
285.5	404	05.097.05.01.3	05.097.05.02.3
299.5	418	03.3	04.3
311.5	430	05.3	06.3
322.5	441	07.3	08.3
337.5	456	35.3	36.3
361.5	480	09.3	10.3
397.5	516	11.3	12.3
422.5	541	13.3	14.3
431.5	550	15.3	16.3
457.5	576	45.3	46.3
469.5	588	17.3	18.3
484.5	603	47.3	48.3
499.5	618	19.3	20.3
509.5	628	21.3	22.3
522.5	641	23.3	24.3
547.5	666	25.3	26.3
557.5	676	39.3	40.3
577.5	696	27.3	28.3
615.5	734	29.3	30.3
634.5	753	37.3	38.3
649.5	768	57.3	58.3
699.5	818	49.3	50.3
741.5	860	31.3	32.3
751.5	870	55.3	56.3
<b>KH.. / KR..</b>		<b>SN 3616</b>	<b>---.542./551---</b>
<b>A</b>	<b>L</b>	<b>left</b>	<b>right</b>
172.5	291	05.097.09.07.3	05.097.09.08.3
649.5	768	13.3	14.3
699.5	818	15.3	16.3
751.5	870	09.3	10.3
866.5	985	17.3	18.3

Brake camshafts with last digit of code number **0** (until 4/91) and **1** (until 2/02) will be replaced with brake camshafts with last digit **3**.  
**Note modified assembly parts.**

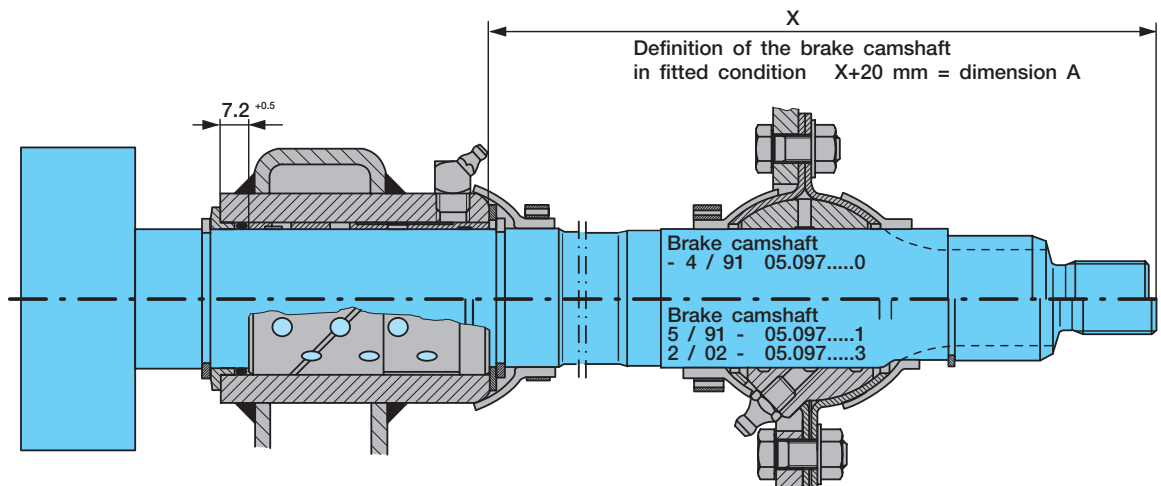
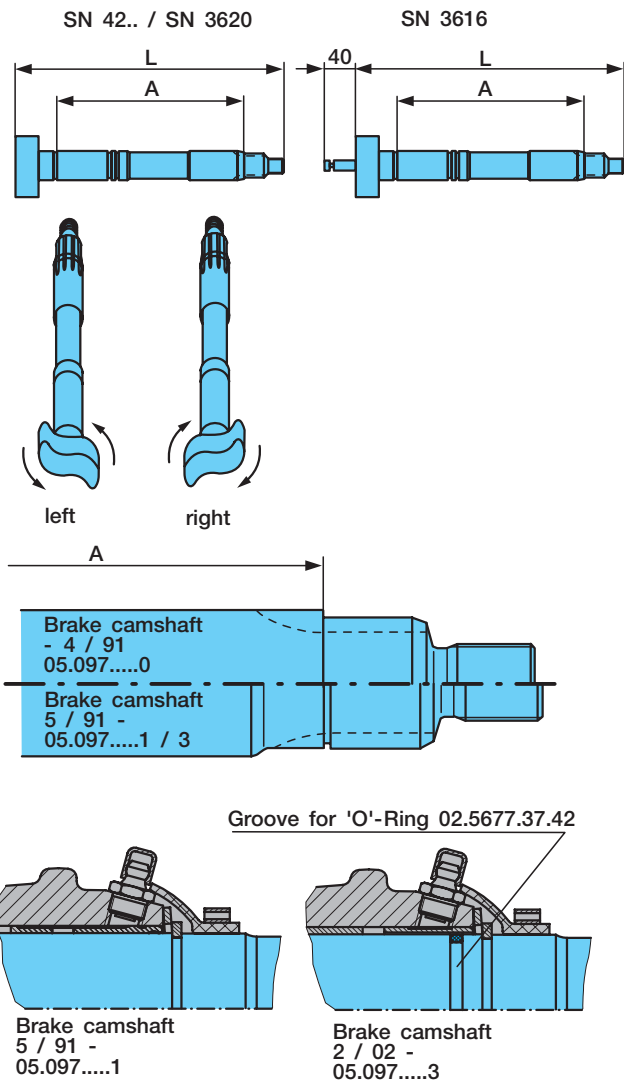

## Brake camshafts 2.1

Item	Designation (Remark)	BPW Code no.	
240	Brake camshaft, left	05.097.60....3	
241	Brake camshaft, right	05.097.60....3	
NH.. / NR..		SN 30..	---.---.50x.---
			---.---.58x.---
			---.---.59x.---
	<b>A</b>	<b>L</b>	
			<b>left</b>
			<b>right</b>
	182.5	307 (333)	05.097.60.27.3
	212.5	337 (363)	19.3
	311.5	436 (462)	39.3
	337.5	462 (488)	11.3
	380.5	505 (531)	43.3
	395.5	520 (546)	01.3
	422.5	547 (573)	15.3
	457.5	582 (608)	13.3
	469.5	594 (620)	03.3
	509.5	634 (660)	09.3
	522.5	647 (673)	07.3
	548.5	673 (699)	23.3
	557.5	682 (708)	05.3
	567.5	692 (718)	49.3
	582.5	707 (733)	45.3
	598.5	723 (749)	41.3
	615.5	740 (766)	17.3
	638.5	763 (789)	47.3
	648.5	773 (799)	25.3
	675.5	800 (826)	21.3
	698.5	823 (849)	37.3
	723.5	848 (874)	31.3
	748.5	873 (899)	33.3
	798.5	923 (949)	35.3
	848.5	973 (999)	29.3

Brake camshafts with last digit of code number **0** (until 4/91), **1** (until 12/95) and **2** (until 2/02) will be replaced with brake camshafts with last digit **3**.  
**Note modified assembly parts.**

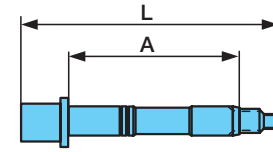

Brake camshaft  
1 / 96 -  
05.097.....2 / 3

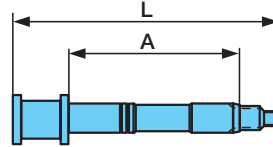

Brake camshaft  
- 12 / 95  
05.097.....0 / 1

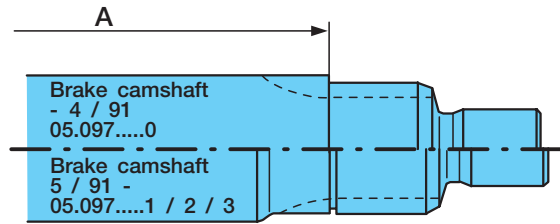
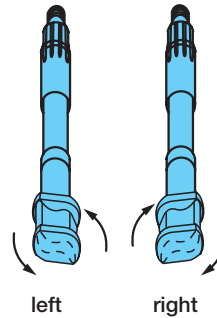

Groove for 'O'-Ring 02.5677.37.42

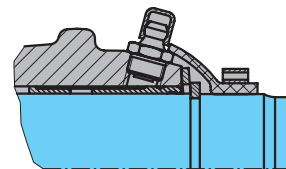

Brake camshaft  
5 / 91 -  
05.097.....1 / 2

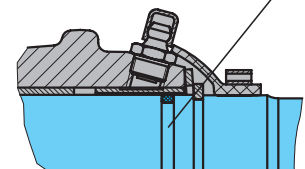

Brake camshaft  
2 / 02 -  
05.097.....3

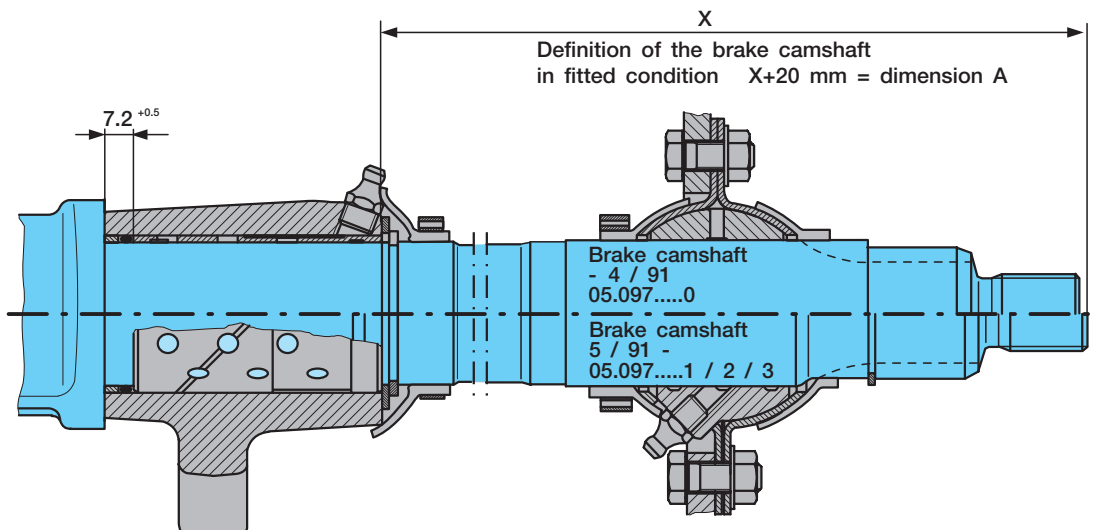

Definition of the brake camshaft  
in fitted condition  $X+20\text{ mm} = \text{dimension A}$

## 2.2 Brake camshaft bearings

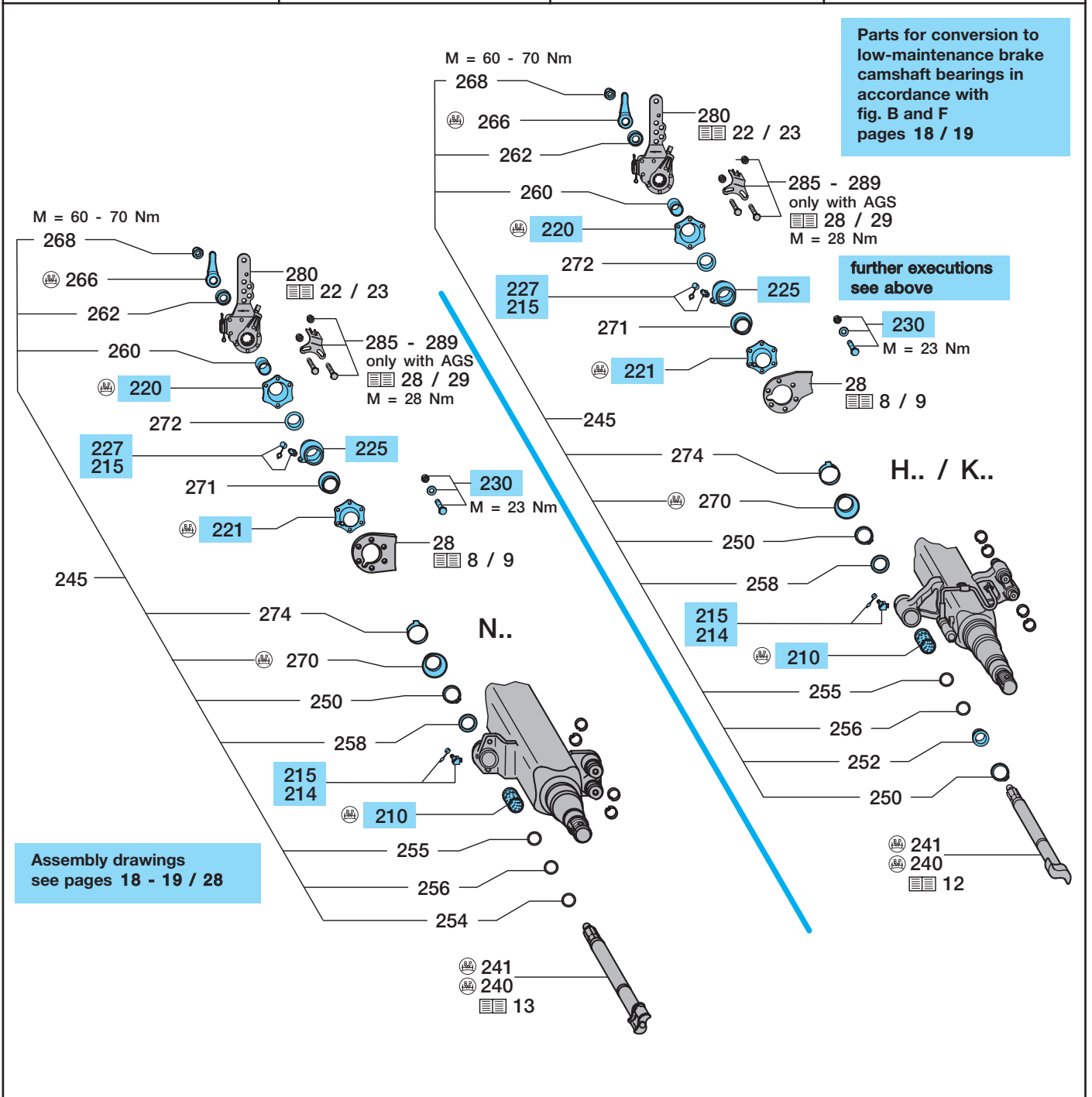
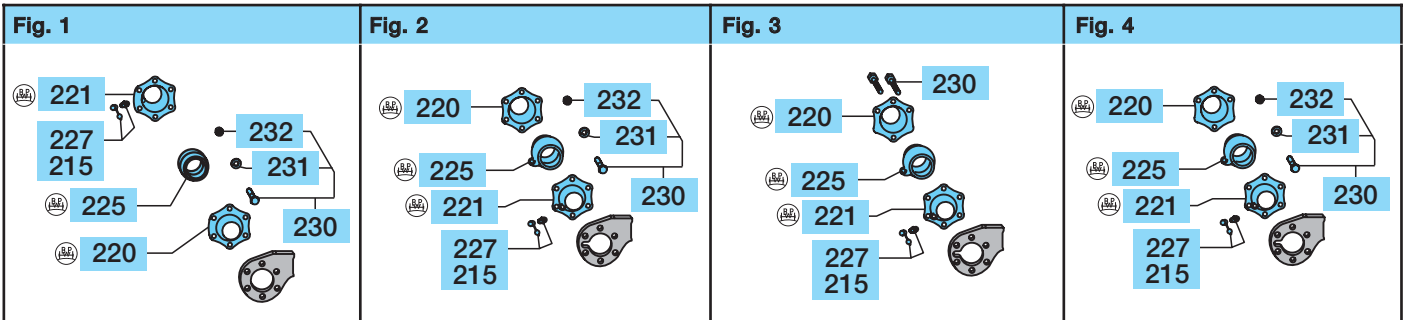

When converting to low-maintenance brake camshaft bearings, low-maintenance automatic slack adjusters type ECO-Master should be used.

Use only BPW special grease ECO-Li 91 or ECO-LiPlus for low-maintenance brake camshaft bearings.

H  
K  
N

## Brake camshaft bearings 2.2

Item	Designation (Remark)	BPW Code no.			Dimension
		H.. / R..	KH.. / KR..	NH.. / NR..	
28	Plate	see page 9			
208	Repair kit conventional brake camshaft bearing (item 210 - 214, 220 - 230, 245, 270, 272, 274) Repair kit low-maintenance brake camshaft bearing (item 210 - 214, 220 - 230, 245, 270, 272, 274)	09.801.02.13.0	for 1 axle side		
		09.801.06.09.1	for 1 axle		
210	Bush	03.112.44.34.0	Ø 42 / 46 x 73		
214	Grease nipple e.g. SN 4222	02.6802.03.50	AM 10 x 1		
		02.6802.06.50	BM 10 x 1 / 45°		
		02.6850.12.50	BM 10 x 1 / 67°		
215	Cap	02.3505.20.00			

H

K

N

		Conventional brake camshaft bearing, ( - 12 / 92 ) Fig. D / E, page 18 / 19	Low-maintenance brake camshaft bearing, bearing box attachment with 6 hexagon screws, ( 1 / 93 - 8 / 97 ) Fig. F, page 18 / 19
		Fig. 1	Fig. 2
219	Repair kit support bearing (incl. item 220 - 230)	09.801.02.15.0	-
220	Bearing box	03.229.02.09.0	03.229.02.16.0
221	Bearing box (for grease nipple)	03.229.02.10.0	03.229.02.17.0
225	Spherical bearing	03.113.14.01.0 Ø 42 / 60 x 38	03.113.14.03.0 Ø 42 / 60 x 38
227	Grease nipple e.g.	02.6850.01.02 AS 8 x 1 / 0° 02.6850.02.02 BS 8 x 1 / 45°	02.6802.14.50 AM 8 x 1 / 8.5 lg.
230	Screw assembly (incl. item 231, 232)	05.865.00.02.0 M 8 x 25 (6x)	05.865.00.02.0 M 8 x 25 (4x)
231	Lock washer	02.5403.08.92 B 8 / 137	02.5403.08.92 B 8 / 137
232	Hexagon nut	02.5202.12.82 M 8 / 934	02.5202.12.82 M 8 / 934
		Low-maintenance brake camshaft bearing, bearing box attachment with 4 locking screws, ( 8 / 97 - 10 / 00 ) Fig. F, page 18 / 19	Low-maintenance brake camshaft bearing, bearing box attachment with 4 hexagon screws, ( 10 / 00 - ) Fig. G, page 18 / 19
		Fig. 3	Fig. 4
220	Bearing box	03.229.02.16.1	03.229.02.18.0
221	Bearing box (for grease nipple)	03.229.02.17.0	03.229.02.19.0
225	Spherical bearing	03.113.14.03.0 Ø 42 / 60 x 38	03.113.14.04.0 Ø 42 / 60 x 38
227	Grease nipple	02.6802.14.50 AM 8 x 1 / 8.5 lg.	02.6802.14.50 AM 8 x 1 / 8.5 lg.
230	Locking screw	02.5403.08.92 B 8 / 137	-
230	Screw assembly (incl. item 231, 232)	05.865.00.02.0 M 8 x 25 (4x)	05.865.00.02.0 M 8 x 25 (4x)
231	Lock washer	02.5403.08.92 B 8 / 137	02.5403.08.92 B 8 / 137
232	Hexagon nut	02.5202.12.82 M 8 / 934	02.5202.12.82 M 8 / 934

No longer available.  
Retrofit to new low-maintenance  
brake camshaft bearing.  
Retrofit kit 09.801.06.09.1

No longer available.  
Retrofit to new low-maintenance  
brake camshaft bearing.  
Retrofit kit 09.801.06.09.1

## 2.2 Brake camshaft bearings

Slack adjuster contact on circlip ( - 10 / 00 )

(Item 260) Circlip 02.5616.05.90

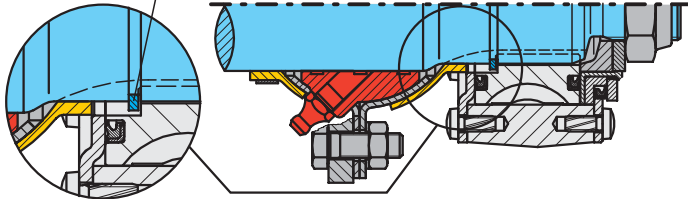

Slack adjuster contact on bush ( 10 / 00 - )

(Item 260) Bush 03.113.03.06.0

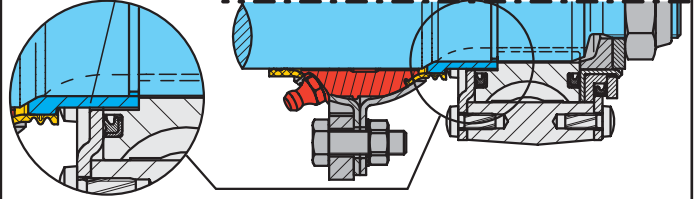

Parts for conversion to low-maintenance brake camshaft bearings in accordance with fig. B and F pages 18 / 19

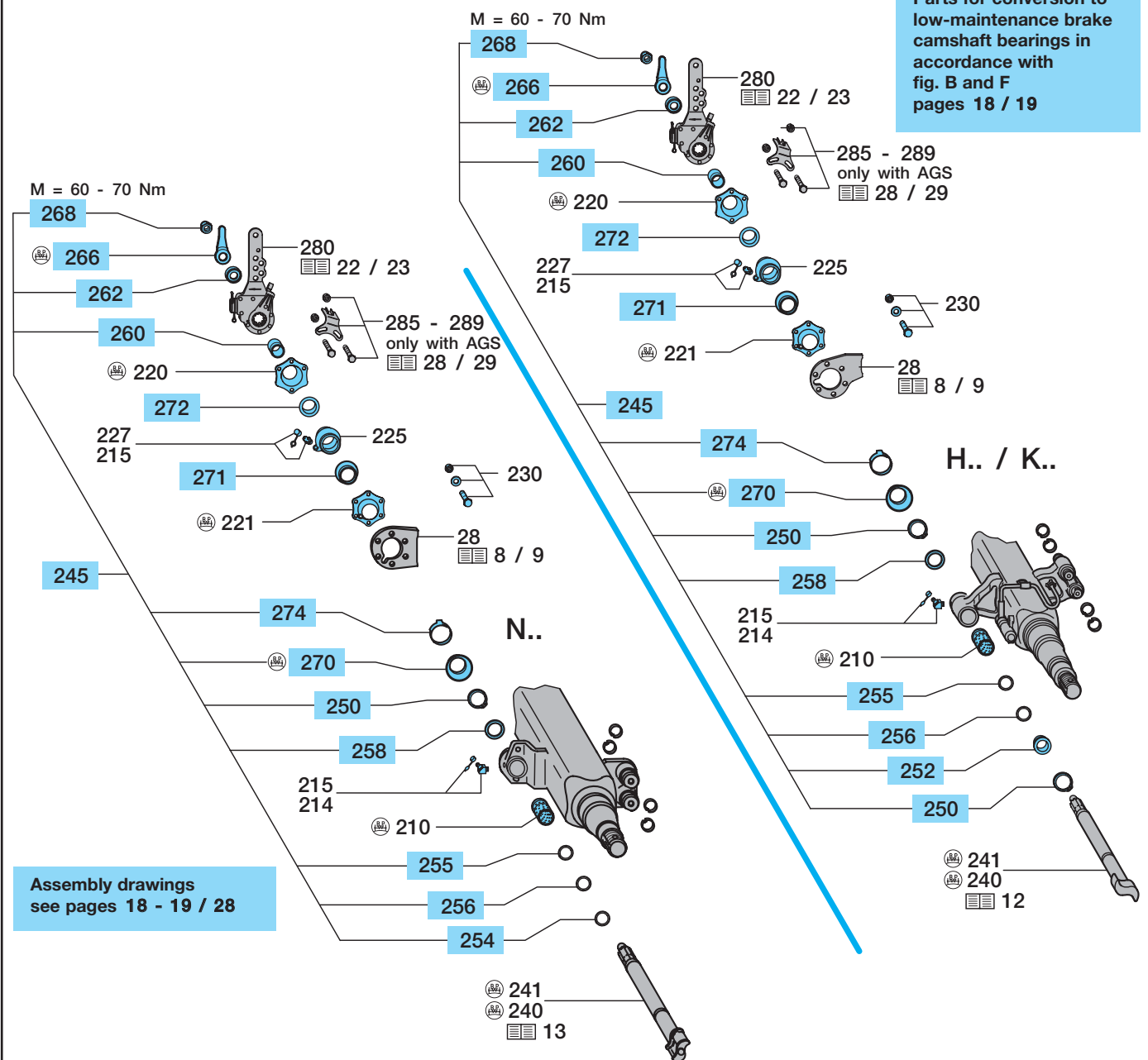

When converting to low-maintenance brake camshaft bearings, low-maintenance automatic slack adjusters type ECO-Master should be used.

Use only BPW special grease ECO-Li 91 or ECO-LiPlus for low-maintenance brake camshaft bearings.



## Brake camshaft bearings 2.2

Item	Designation (Remark)	BPW Code no.			Dimension		
		H.. / R..	KH.. / KR..	NH.. / NR..	H.. / R..	KH.. / KR..	NH.. / NR..
		Brake camshaft with last digit 0 / 1 / 2, - 2 / 02 Fig. A / B / D / E / F, page 18 / 19			Brake camshafts with last digit 3, 2 / 02 - Fig. C / G, page 18 / 19		
245	Assembly kit (item 250 - 262, 268, 270, 274)	09.801.00.14.2	for 1 axle side		09.801.00.43.1	for 1 axle side	
250	Circlip	02.5676.01.00	A 42 x 2.5 (N.. 2x)		02.5676.01.00	A 42 x 2.5 (N.. 2x)	
252	Ring (Thrust ring)	03.310.12.24.0	1) Ø 42 / 46 / 55 x 7		03.310.12.24.0	Ø 42 / 46 / 55 x 7	
254	Ring	03.310.81.02.0	Ø 42 / 46 x 4 (only N..)		03.310.81.02.0	Ø 42 / 46 x 4 (only N..)	
255	'O'-Ring	-			02.5677.37.42	Ø 37 x 2.6 (black)	
256	'O'-Ring	02.5679.23.00	Ø 40 x 2.5 (green)		02.5679.23.00	Ø 40 x 2.5 (green)	
258	Seal	03.120.42.02.0	Ø 42 / 56 x 2		03.120.42.02.0	Ø 42 / 56 x 2	
260	Circlip ( - 10 / 00)	02.5616.05.90	2) Ø 37 / 41 x 2		-		
260	Bush ( 10 / 00 - )	03.113.03.06.0	Ø 37.4 / 45 x 21.3		03.113.03.06.0	Ø 37.4 / 45 x 21.3	
262	Washer (for GSK/ECO-Master 5 / 91 - )	03.320.11.16.1	Ø 22.5 / 42 x 10.5		03.320.11.16.1	Ø 22.5 / 42 x 10.5	
266	Lever (Brake lining wear indicator)	03.190.14.07.1	100 mm		03.190.14.07.1	100 mm	
		03.190.14.08.1	60 mm		03.190.14.08.1	60 mm	
268	Lock nut	03.260.14.08.0	M 22 x 1.5 / SW 32		03.260.14.08.0	M 22 x 1.5 / SW 32	
		Conventional brake camshaft bearing, brake camshaft with last digit 0, - 12 / 92 Fig. A / C, page 18 / 19		Low-maintenance brake camshaft bearing, brake camshaft with last digit 1 and 2, 1 / 93 - 10 / 00 Fig. B/C/E/F, page 18 / 19		Low-maintenance brake camshaft bearing, brake camshaft with last digit 2 / 3, 10 / 00 - Fig. C / G, page 18 / 19	
270	Seal	03.120.43.14.0	Ø 41 x 25		03.120.43.14.0	Ø 41 x 25	
271	Seal	-			03.120.43.12.0	Ø 41 x 20	
272	Seal	-			03.120.43.10.0	Ø 34 x 26	
274	Circlip	03.350.30.02.0	Ø 49 x 9		03.350.30.02.0	Ø 49 x 9	

1) Replacement for rings 03.310.32.09.0 and 03.310.81.02.0, only for H.. / K..

2) With brake camshaft having 1 or 2 as last digit

2.2 Brake camshaft bearings

H  
K

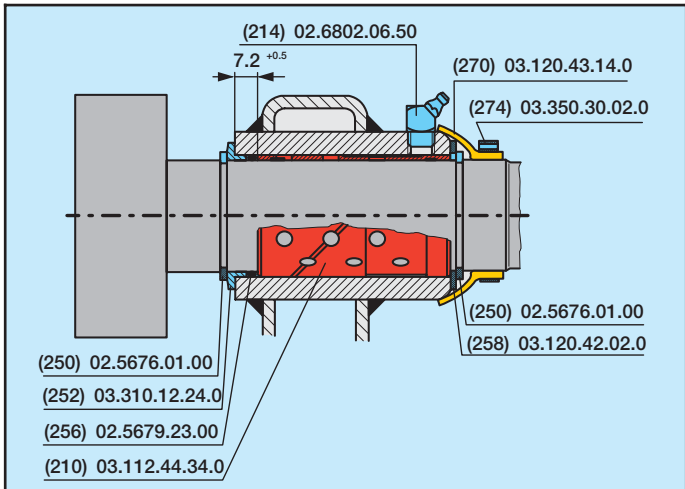

**A** Conventional brake camshaft bearing  
**B** Low-maintenance brake camshaft bearing, - 2 / 02

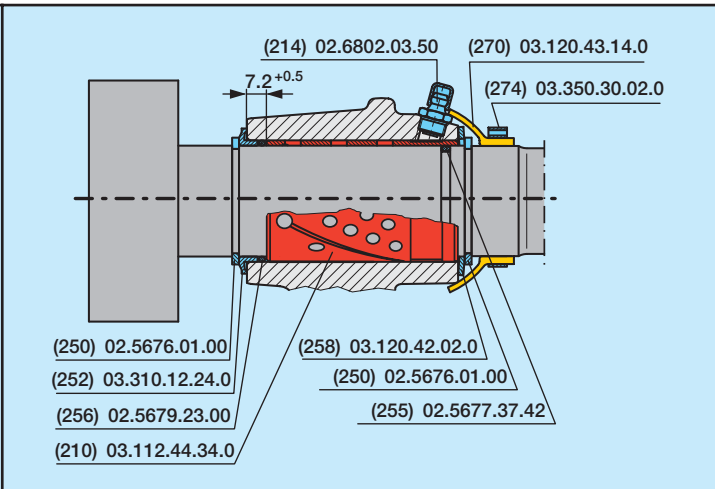

**C** Low-maintenance brake camshaft bearing, 2 / 02 -  
New brake camshaft 05.097.60....3, 2 / 02 -

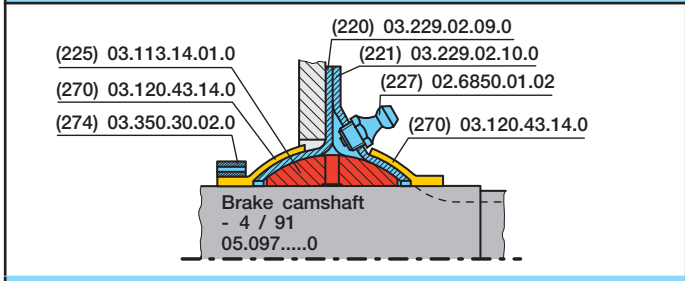

**D** Conventional brake camshaft bearing, - 12 / 92  
Old brake camshaft 05.097.05(09)....0, - 4 / 91

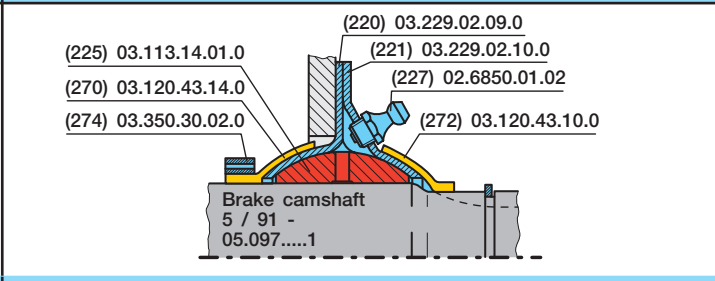

**E** Conventional brake camshaft bearing, - 12 / 92  
Brake camshaft 05.097.05(09)....1, 5 / 91 - 10 / 00

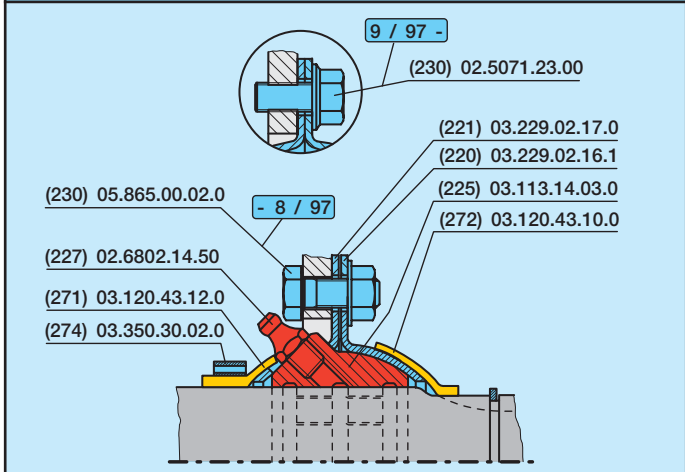

**F** Low-maintenance brake camshaft bearing, 1 / 93 - 10 / 00

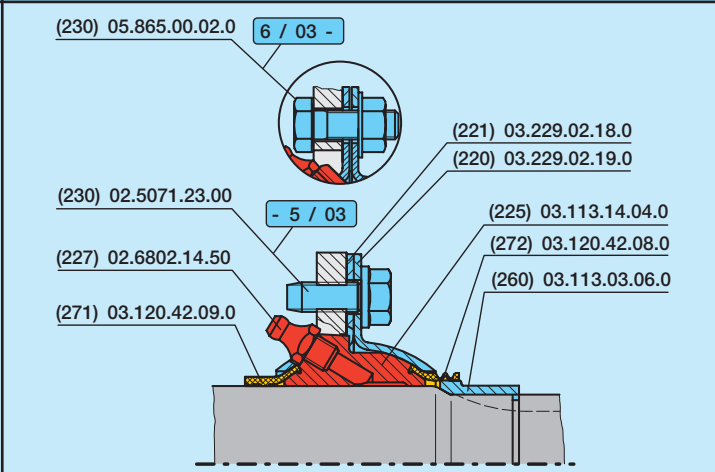

**G** Low-maintenance brake camshaft bearing, 10 / 00 -

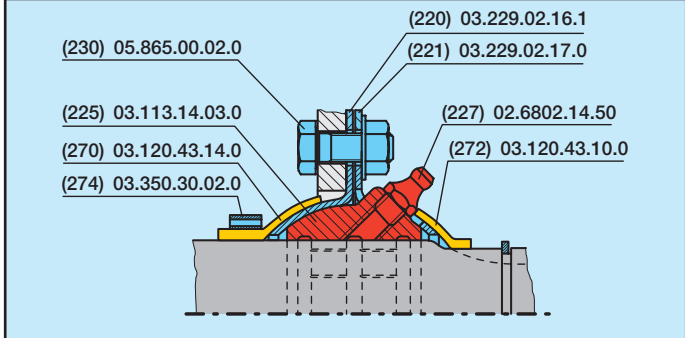

**H** Conversion to low-maintenance brake camshaft bearing  
Support plates without a lubrication nipple recess  
Brake camshaft 05.097.05....1/2, 5 / 91 -

## Brake camshaft bearings 2.2

N

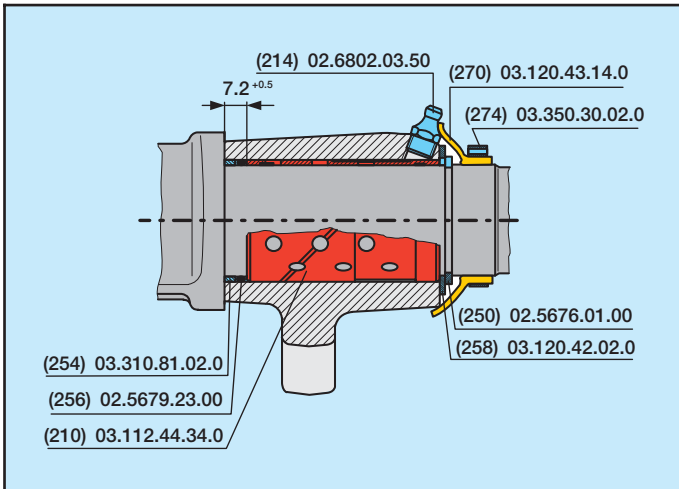

**A** Conventional brake camshaft bearing  
**B** Low-maintenance brake camshaft bearing, - 2 / 02

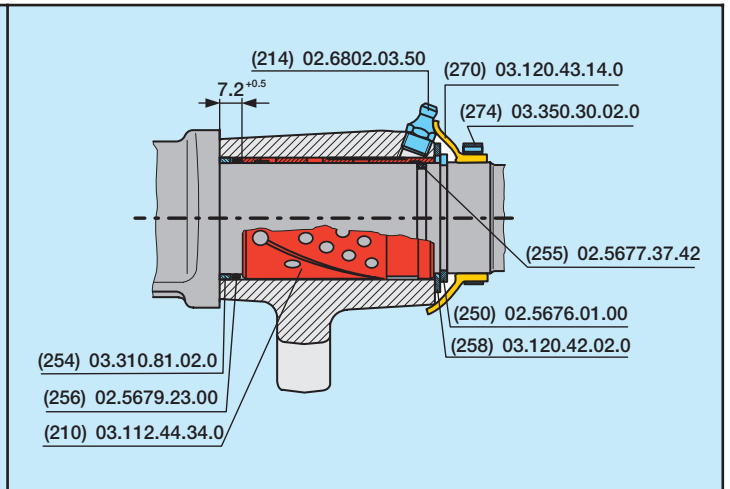

**C** Low-maintenance brake camshaft bearing, 2 / 02 -  
 New brake camshaft 05.097.60....3, 2 / 02 -

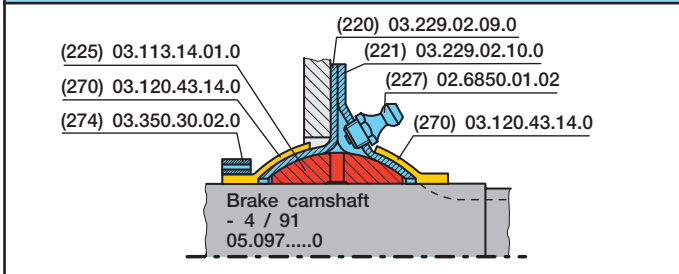

**D** Conventional brake camshaft bearing, - 12 / 92  
 Old brake camshaft 05.097.60....0, - 4 / 91

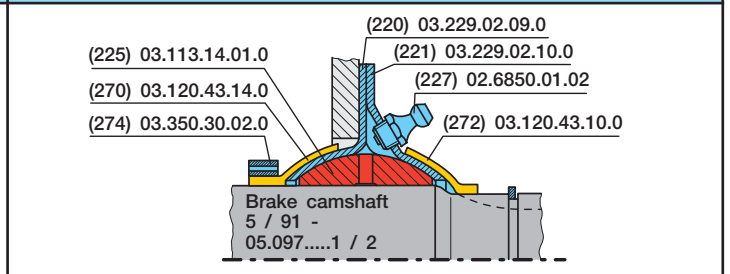

**E** Conventional brake camshaft bearing, - 12 / 92  
 Brake camshaft 05.097.60....1/2, 5 / 91 - 10 / 00

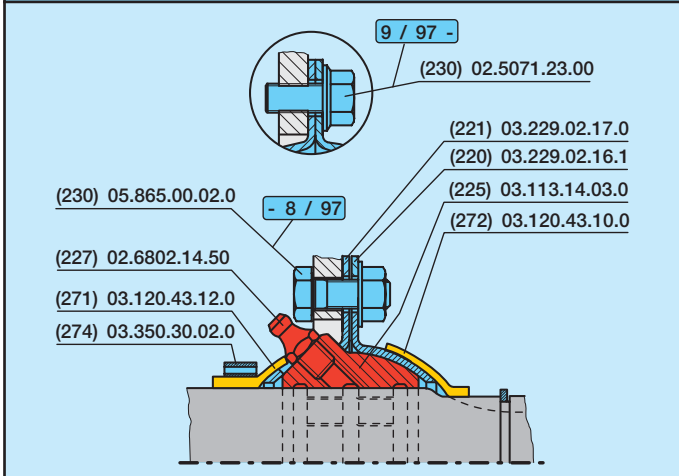

**F** Low-maintenance brake camshaft bearing, 1 / 93 - 10 / 00

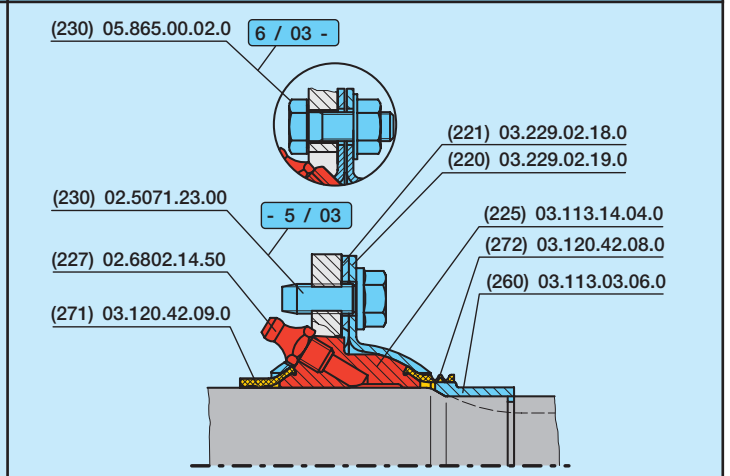

**G** Low-maintenance brake camshaft bearing, 10 / 00 -

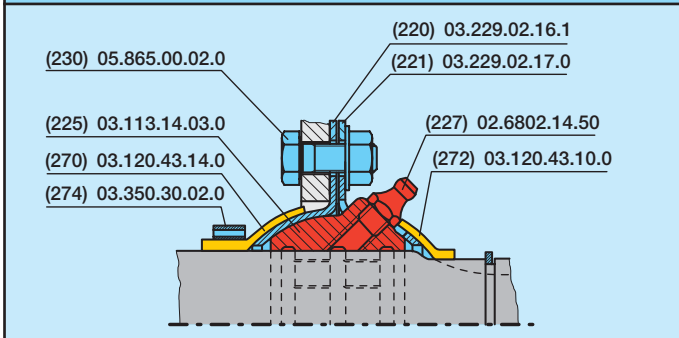

**H** Conversion to low-maintenance brake camshaft bearing  
 Support plates without a lubrication nipple recess  
 Brake camshaft 05.097.60....1/2, 5 / 91 -

### 3 Slack adjusters

H

#### General

##### BPW Slack adjusters

The necessary brake cylinder stroke increases as the brake lining thickness reduces.

The slack adjuster makes up for this change and keeps the brake cylinder stroke in the optimum range at all times.

In most countries, fitting automatic slack adjusters is a statutory requirement.



##### The principle of automatic adjustment

Brake linings and brake drums are parts subject to wear. As the thickness of the material is reduced, the brake cylinder stroke increases, meaning that the brake camshaft has to rotate further. In this case, the automatic function of the ECO-Master automatic slack adjuster provides the necessary adjustment. As a result, the brake cylinder stroke is always kept within the same, optimum range.

The adjustment stroke is designed so that there is always sufficient air gap even at higher levels of elasticity and given thermal expansion of the adjacent components (e.g. the brake drum).

Levers with different shapes and crank values are available depending on the particular installation conditions.

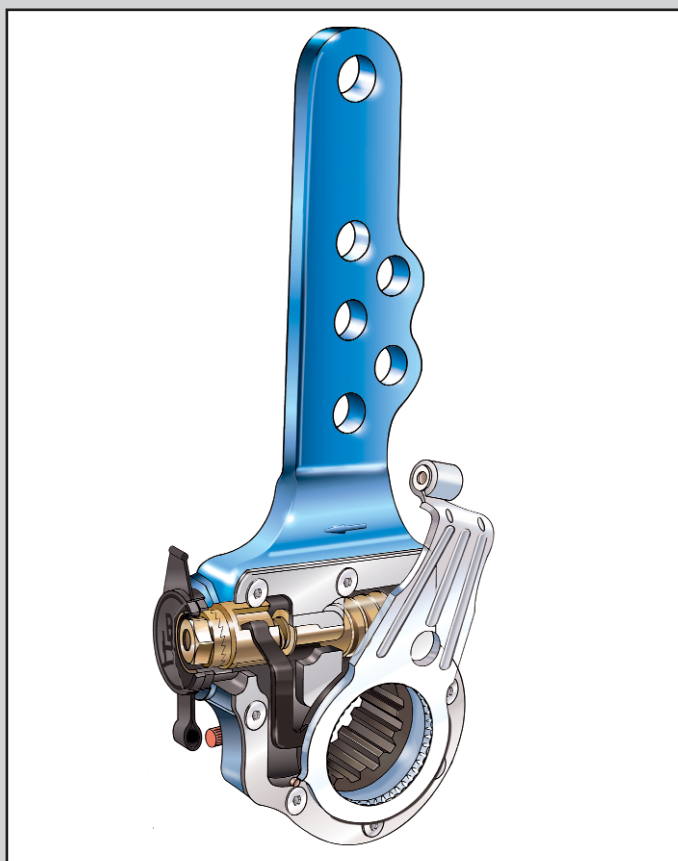

## Determining replacement slack adjusters

The BPW code number is punched into the cover plate of the slack adjuster.

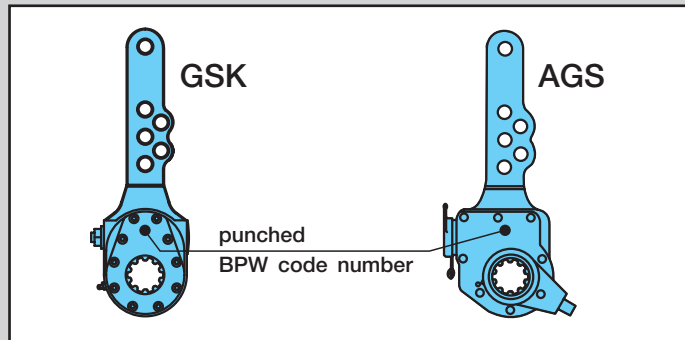

If there is no BPW code number or it is not legible, the slack adjuster can be identified on the basis of the shape and dimensions.

1. **Automatic (AGS) or manual slack adjuster (GSK)**
2. **Lever length (HL)**
3. **Crank value ( $\beta$ )**
4. **Offset (X)**
5. **Position of fixed point holder in AGS ( $\alpha$ )**

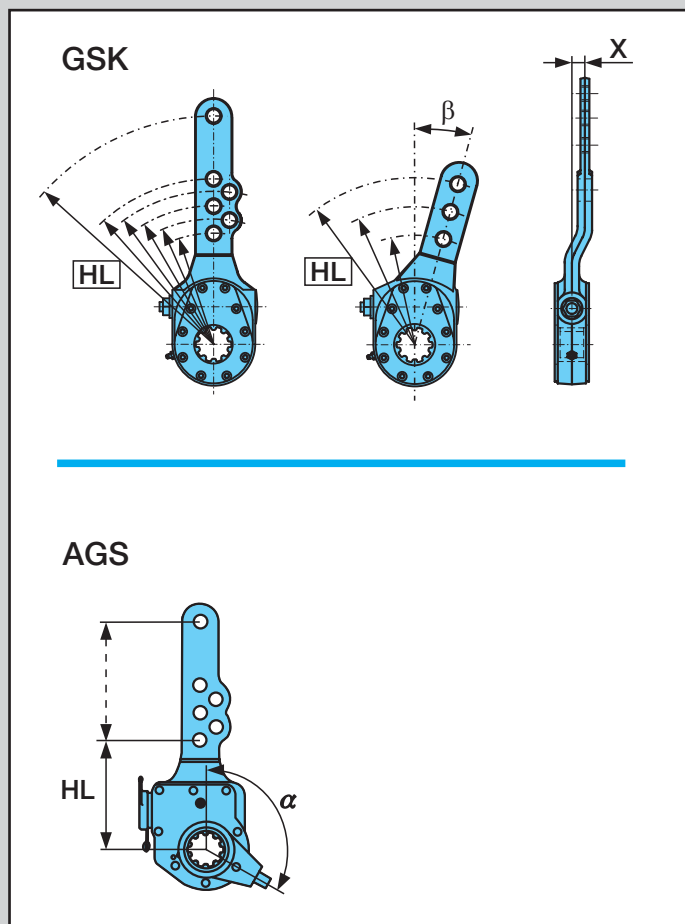

3.1 Manual slack adjusters (GSK), return springs

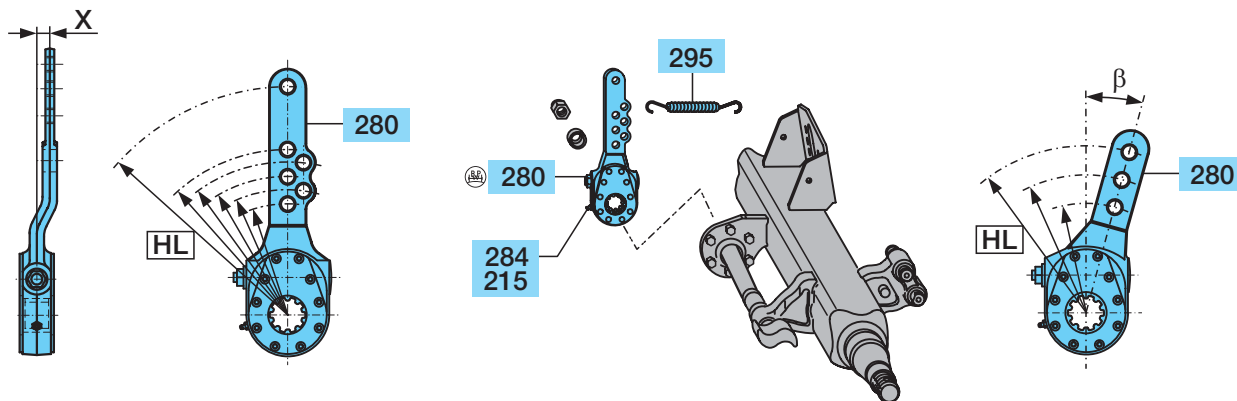

Item	Designation (Remark)	BPW Code no.	Dimension				
280 / 281	Slack adjuster (incl. item 215, 284)	<b>GSK (manual)</b>					
		<b>H.. / R..</b>		<b>KH.. / KR..</b>		<b>NH.. / NR..</b>	
	<b>HL 120 / 150 / 180</b>	05.174.52.34.0	3-holes	05.174.52.34.0	3-holes	05.174.52.34.0	3-holes
				05.174.65.20.0	3-holes / $\beta$ 15°	05.174.65.20.0	3-holes / $\beta$ 15°
	<b>HL 230 / 260 / 290 / X=14</b>	05.174.58.13.0	3-holes left	-	-	-	-
		05.174.58.14.0	3-holes right	-	-	-	-
	<b>HL 150 / 150 / 180 / 250</b>	05.174.52.61.0	4-holes	05.174.52.61.0	4-holes	05.174.52.43.0	4-holes / $\beta$ 15°
		-		05.174.52.43.0	4-holes / $\beta$ 15°	-	-
	<b>HL 120 / 150 / 195 / 250</b>	-		-		05.174.65.14.0	4-holes / $\beta$ 15°
	<b>HL 120 / 135 / 150 / 165 / 180</b>	05.174.65.22.0	5-holes	05.174.65.22.0	5-holes	-	-
	<b>HL 120 / 135 / 150 / 165 / 180 / 195 / 250</b>	<b>05.174.65.13.0</b>	<b>7-holes</b>	<b>05.174.65.13.0</b>	<b>7-holes</b>	<b>05.174.65.13.0</b>	<b>7-holes</b>
284	Grease nipple	02.6850.01.02	AS 8 x 1 / 0°				
215	Cap	02.3505.20.00					

Item	Designation (Remark)	BPW Code no.	Dimension				
		<b>H.. / R..</b>		<b>KH.. / KR..</b>		<b>NH.. / NR..</b>	
295	Return spring	03.397.26.04.0	$\emptyset$ 24/2.8x69	03.397.26.04.0	$\emptyset$ 24/2.8x69	03.397.26.08.0	$\emptyset$ 21/2.8x84
		03.397.26.09.0	$\emptyset$ 24/2.8x72	03.397.26.08.0	$\emptyset$ 21/2.8x84	03.397.26.06.0	$\emptyset$ 24/2.8x89
		03.397.26.08.0	$\emptyset$ 24/2.8x84	03.397.26.06.0	$\emptyset$ 24/2.8x89	05.397.28.01.0	$\emptyset$ 31/2.8x120
		03.397.26.06.0	$\emptyset$ 24/2.8x89	05.397.28.01.0	$\emptyset$ 31/2.8x120	<b>05.397.26.03.0</b>	<b><math>\emptyset</math> 26/2.8x148</b>
		05.397.28.01.0	$\emptyset$ 31/2.8x120	<b>05.397.26.03.0</b>	<b><math>\emptyset</math> 26/2.8x148</b>	05.397.26.02.0	$\emptyset$ 22.5/2.5x235
		<b>05.397.26.03.0</b>	<b><math>\emptyset</math> 26/2.8x148</b>	05.397.28.02.0	$\emptyset$ 22.5/2.5x235		
		05.397.26.05.0	$\emptyset$ 22.5/2.5x185				
		05.397.26.02.0	$\emptyset$ 22.5/2.5x235				

## Automatic slack adjusters (ECO-Master) 3.2

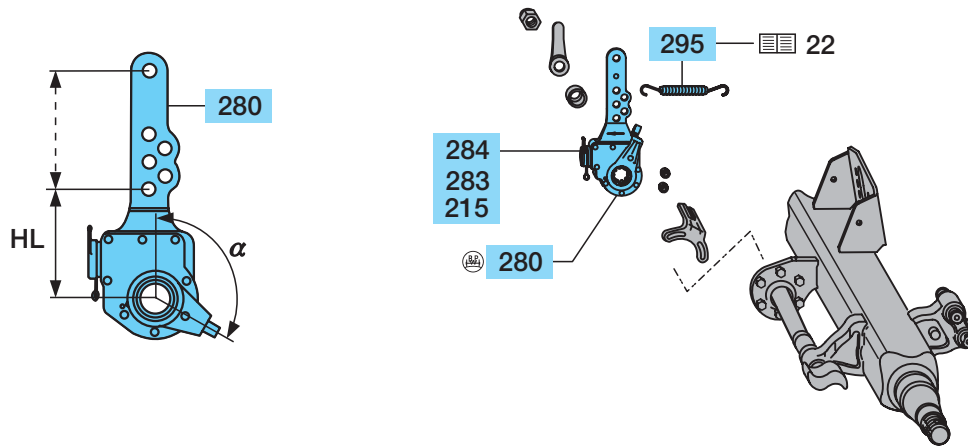

Item	Designation (Remark)	BPW Code no.	Dimension	
280	Slack adjuster (incl. item 215, 283, 284)	<b>ECO-Master (autom.) ( 5 / 91 - )</b>		<b>Slack adjuster kit (item 280, 285 - 289)</b>
		<b>H.. / R..</b>	<b>KH.. / KR..</b>	
	<b>HL 120 / 135 / 150 / 165</b>	<b>05.174.82.67.3</b>	<b>5-holes, <math>\alpha = 24^\circ</math></b>	<b>05.574.83.01.3</b>
		05.174.83.06.3	5-holes, $\alpha = 60^\circ$	05.574.82.68.3
		05.174.82.75.3	5-holes, $\alpha = 60^\circ$	05.574.83.08.3
		05.174.82.22.3	5-holes, $\alpha = 120^\circ$	05.574.82.55.3
		05.174.82.31.3	5-holes, $\alpha = 180^\circ$	05.574.82.67.3
		05.174.88.51.3	5-holes, $\alpha = 210^\circ$	05.574.88.22.3
		05.174.82.32.3	5-holes, $\alpha = 210^\circ$	05.574.82.66.3
	<b>HL 120 / 135 / 150 / 165 / 240</b>	05.174.82.40.3	6-holes, $\alpha = 210^\circ$	05.574.82.45.3
	<b>HL 120 / 135 / 150 / 165 / 250</b>	<b>05.174.82.63.3</b>	<b>6-holes, <math>\alpha = 24^\circ</math></b>	<b>05.574.82.87.3</b>
		05.174.83.05.3	6-holes, $\alpha = 60^\circ$	05.574.83.07.3
		<b>05.174.82.21.3</b>	<b>6-holes, <math>\alpha = 120^\circ</math></b>	<b>05.574.82.43.3</b>
		<b>05.174.82.24.3</b>	<b>6-holes, <math>\alpha = 180^\circ</math></b>	<b>05.574.82.44.3</b>
		05.174.82.26.3	6-holes, $\alpha = 210^\circ$	05.574.82.65.3
		05.174.83.04.3	6-holes, $\alpha = 210^\circ$	05.574.82.88.3
			<b>NH.. / NR..</b>	
	<b>HL 150 / 165</b>	05.174.89.05.3	3-holes, $\alpha = 180^\circ$	-
	<b>HL 120 / 135 / 150 / 165</b>	<b>05.174.82.67.3</b>	<b>5-holes, <math>\alpha = 24^\circ</math></b>	<b>05.574.83.01.3</b>
		05.174.82.14.3	5-holes, $\alpha = 180^\circ$	05.574.82.67.3
	05.174.82.31.3	5-holes, $\alpha = 180^\circ$	05.574.82.59.3	
	05.174.82.32.3	5-holes, $\alpha = 210^\circ$	05.574.82.66.3	
<b>HL 120 / 135 / 150 / 165</b>	05.174.88.51.3	5-holes, $\alpha = 210^\circ$	05.574.88.22.3	
<b>HL 120 / 135 / 150 / 165 / 250</b>	<b>05.174.82.63.3</b>	<b>6-holes, <math>\alpha = 24^\circ</math></b>	<b>05.574.82.87.3</b>	
	05.174.82.24.3	6-holes, $\alpha = 180^\circ$	05.574.82.44.3	
	05.174.83.04.3	6-holes, $\alpha = 210^\circ$	05.574.82.88.3	
283	Cap	03.211.90.15.0		
284	Grease nipple	02.6850.01.02 AS 8 x 1 / 0°		
215	Cap	02.3505.20.00		

3.2 Slack adjusters (ECO-Master) - Axle series H.. / R..

H

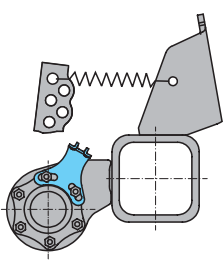
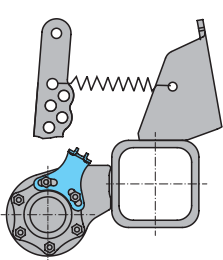
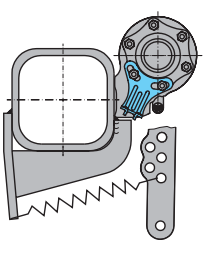
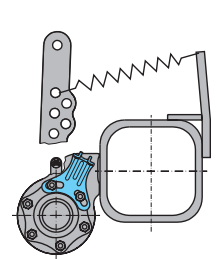
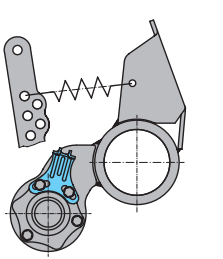
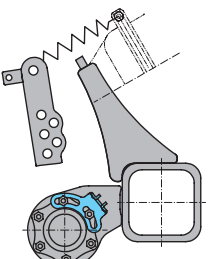
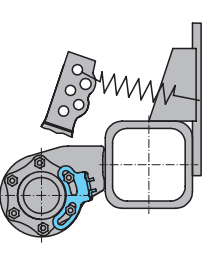
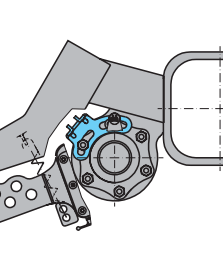
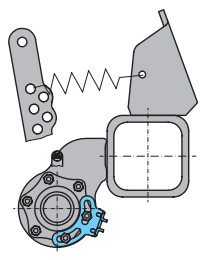
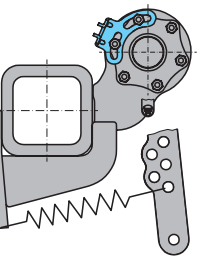
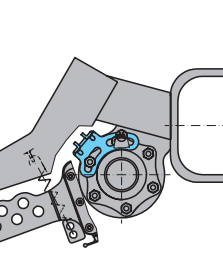
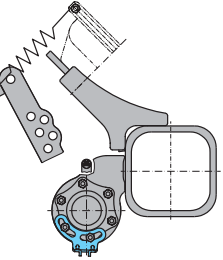
<p>H..</p>  <p>ECO-Master <math>\alpha=24^\circ</math> 05.174.82.67.3 Return spring 05.397.26.03.0 Booster bracket <math>25^\circ/30^\circ</math> 03.182.34.77.0 <math>16^\circ</math> 03.182.35.78.0 Piston rod 227 mm</p>	<p>H..</p>  <p>ECO-Master <math>\alpha=24^\circ</math> 05.174.82.63.3 Return spring 05.397.26.03.0 Booster bracket <math>30^\circ</math> 03.182.34.77.0 <math>16^\circ</math> 03.182.35.78.0 Piston rod 227 mm</p>	<p>H..</p>  <p>ECO-Master <math>\alpha=24^\circ</math> 05.174.82.63.3 Return spring 05.397.26.05.0 Booster bracket <math>\square</math> 150 05.182.07.26.0 Piston rod 227 mm</p>
<p>H..</p>  <p>ECO-Master <math>\alpha=24^\circ</math> 05.174.82.63.3 Return spring 05.397.26.05.0 Booster bracket 03.182.07.21.0 Piston rod 227 mm</p>	<p>R..</p>  <p>ECO-Master <math>\alpha=24^\circ</math> 05.174.82.63.3 Return spring 05.397.26.03.0 Booster bracket 03.182.34.58.0 Piston rod 227 mm</p>	<p>H..</p>  <p>ECO-Master <math>\alpha=60^\circ</math> 05.174.83.05.3 Return spring 05.397.26.03.0 Booster bracket 05.182.17.38.0 Piston rod 110 mm</p>
<p>H..</p>  <p>ECO-Master <math>\alpha=60^\circ</math> 05.174.82.75.3 Return spring 05.397.26.03.0 Booster bracket 05.182.16.57.0 Piston rod 180 mm</p>	<p>H..</p>  <p>ECO-Master <math>\alpha=60^\circ</math> 05.174.82.36.3 Return spring 03.397.26.04.0 Booster bracket <math>25^\circ/30^\circ</math> 05.182.33.15.0 <math>16^\circ</math> L 05.182.45.03.0 <math>16^\circ</math> R 05.182.45.04.0 Piston rod 80 mm</p>	<p>H..</p>  <p>ECO-Master <math>\alpha=120^\circ</math> 05.174.82.21.3 Return spring 05.397.26.03.0 Booster bracket <math>30^\circ</math> 03.182.34.77.0 <math>16^\circ</math> 03.182.35.78.0 Piston rod 227 mm</p>
<p>H..</p>  <p>ECO-Master <math>\alpha=120^\circ</math> 05.174.82.21.3 Return spring 05.397.26.05.0 Booster br. <math>\square</math> 120 <math>30^\circ</math> 05.182.07.25.0 <math>\square</math> 150 05.182.07.26.0 Piston rod 227 mm</p>	<p>H..</p>  <p>ECO-Master <math>\alpha=180^\circ</math> 05.174.82.14.3 Return spring 05.397.26.03.0 Booster bracket 05.182.07.37.0 Piston rod 190 mm</p>	<p>H..</p>  <p>ECO-Master <math>\alpha=210^\circ</math> 05.174.82.40.3 Return spring 05.397.26.03.0 Booster bracket 05.182.16.69.0 Piston rod 110 mm</p>



## Slack adjusters (ECO-Master) - Axle series KH.. / KR.. 3.2

K

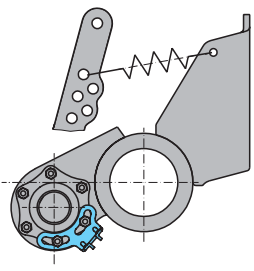
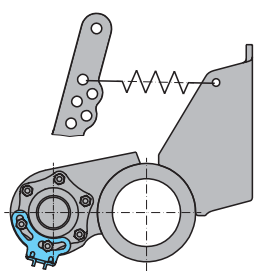
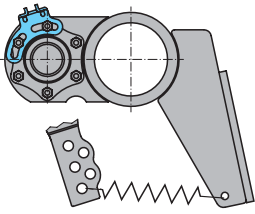
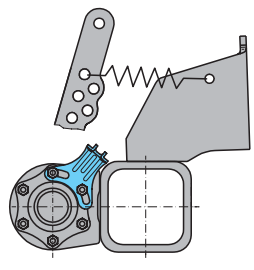
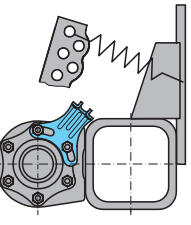
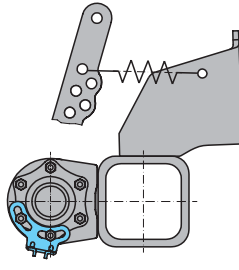
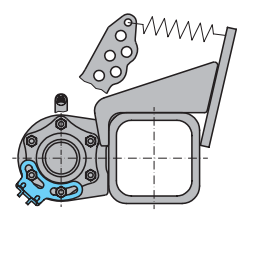
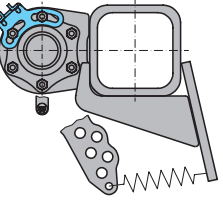
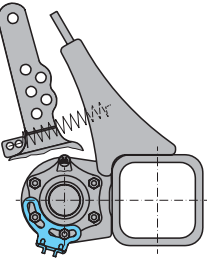
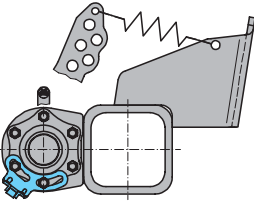
<p><b>KR..</b></p>  <p>ECO-Master <math>\alpha=120^\circ</math> 05.174.82.21.3 Return spring 05.397.26.03.0 Booster bracket 03.182.34.95.0 Piston rod 227 mm</p>	<p><b>KR..</b></p>  <p>ECO-Master <math>\alpha=180^\circ</math> 05.174.82.24.3 Return spring 05.397.26.03.0 Booster bracket 03.182.34.95.0 Piston rod 227 mm</p>	<p><b>KR..</b></p>  <p>ECO-Master <math>\alpha=210^\circ</math> 05.174.82.32.3 Return spring 05.397.26.03.0 Booster bracket 05.182.16.60.0 Piston rod 227 mm</p>
<p><b>KH..</b></p>  <p>ECO-Master <math>\alpha=24^\circ</math> 05.174.82.63.3 Return spring 03.397.26.03.0 Booster bracket 03.182.35.80.0 Piston rod 227 mm</p>	<p><b>KH..</b></p>  <p>ECO-Master <math>\alpha=24^\circ</math> 05.174.82.67.3 Return spring 05.397.26.03.0 Booster bracket 03.182.33.10.0 Piston rod 180 mm</p>	<p><b>KH..</b></p>  <p>ECO-Master <math>\alpha=180^\circ</math> 05.174.82.24.3 Return spring 05.397.26.03.0 Booster bracket 03.182.35.80.0 Piston rod 227 mm</p>
<p><b>KH..</b></p>  <p>ECO-Master <math>\alpha=194^\circ</math> 05.174.88.51.3 Return spring 05.397.28.01.0 Booster bracket 05.182.27.03.0 Piston rod 155 mm</p>	<p><b>KH..</b></p>  <p>ECO-Master <math>\alpha=194^\circ</math> 05.174.88.51.3 Return spring 03.397.28.01.0 Booster bracket 05.182.27.03.0 Piston rod 155 mm</p>	<p><b>KH..</b></p>  <p>ECO-Master <math>\alpha=210^\circ</math> 05.174.83.04.3 Return spring 05.397.26.06.0 Booster bracket 03.182.17.45.0 Piston rod 82 mm</p>
<p><b>KH..</b></p>  <p>ECO-Master <math>\alpha=210^\circ</math> 05.174.88.51.3 Return spring 05.397.26.03.0 Booster bracket 03.182.35.83.0 Piston rod 227 mm</p>		

3.2 Slack adjusters (ECO-Master) - Axle series NH.. / NR..

N

NR..

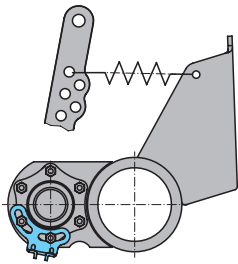

ECO-Master  $\alpha=180^\circ$  05.174.82.24.3  
Return spring 05.397.26.03.0  
Booster bracket  $25^\circ/30^\circ$  03.182.34.65.0  
Piston rod 227 mm

NR..

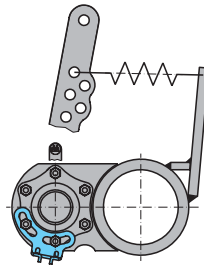

ECO-Master  $\alpha=180^\circ$  05.174.82.24.3  
 $\alpha=180^\circ$  PAL 05.174.82.14.3  
Return spring 05.397.26.03.0  
Booster bracket 03.182.07.21.0  
Piston rod 180 mm

NR..

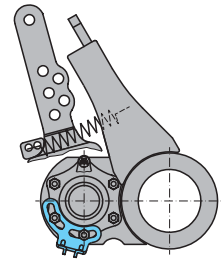

ECO-Master  $\alpha=210^\circ$  05.174.82.40.3  
Return spring 05.397.26.03.0  
Booster bracket 05.182.17.14.0  
Piston rod 82 mm

NR..

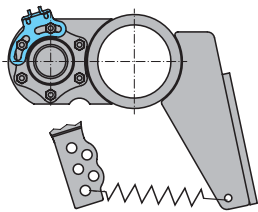

ECO-Master  $\alpha=180^\circ$  05.174.82.14.3  
Return spring 05.397.26.03.0  
Booster bracket 03.182.16.60.0  
Piston rod 227 mm

NH..

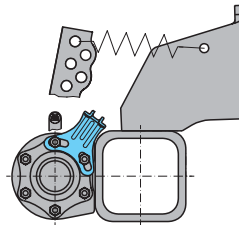

ECO-Master  $\alpha=24^\circ$  05.174.82.67.3  
Return spring 05.397.26.03.0  
Booster bracket 03.182.35.80.0  
Piston rod 227 mm

NH..

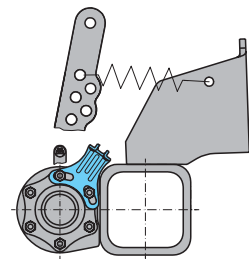

ECO-Master  $\alpha=24^\circ$  05.174.82.63.3  
Return spring 05.397.26.03.0  
Booster bracket 05.182.35.80.0  
Piston rod 227 mm

NH..

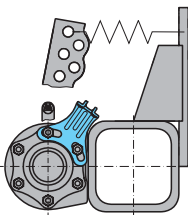

ECO-Master  $\alpha=24^\circ$  05.174.82.67.3  
Return spring 05.397.28.01.0  
Booster bracket 03.182.33.10.0  
Piston rod 170 mm

NH..

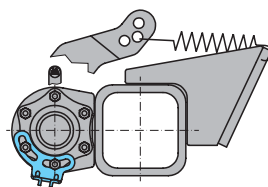

ECO-Master  $\alpha=180^\circ$  05.174.89.05.3  
Return spring 05.397.26.03.0  
Booster bracket 05.182.16.95.0  
Piston rod 180 mm

NH..

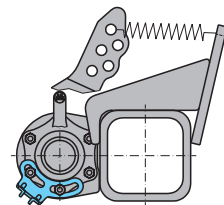

ECO-Master  $\alpha=210^\circ$  05.174.88.99.3  
05.174.88.51.3  
Return spring 05.397.28.01.0  
Booster bracket 05.182.27.03.0  
Piston rod 155 mm

NH..

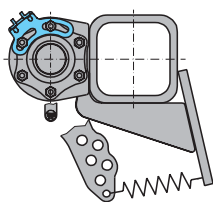

ECO-Master  $\alpha=210^\circ$  05.174.88.99.3  
05.174.88.51.3  
Return spring 05.397.28.01.0  
Booster bracket 05.182.27.03.0  
Piston rod 155 mm

NH..

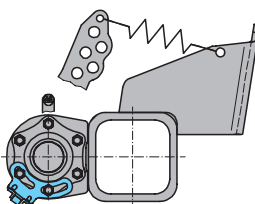

ECO-Master  $\alpha=210^\circ$  05.174.88.51.3  
Return spring 05.397.26.03.0  
Booster bracket 03.182.35.83.0  
Piston rod 227 mm

NH..

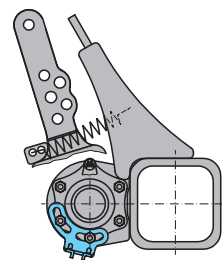

ECO-Master  $\alpha=210^\circ$  05.174.82.64.3  
Return spring 03.397.26.06.0  
Booster bracket 03.182.17.45.0  
Piston rod 82 mm

# Installation instructions ECO-Master 3.3

H  
K  
N

<p><b>1</b></p>	<p><b>2</b></p> <p>60 - 70 Nm</p>
<p><b>3</b></p>	<p><b>4</b></p>
<p><b>5</b></p>	<p><b>6</b></p>
<p><b>7</b></p> <p> <math>a_{min} = 0,1 \times b</math>  <math>a_{max} = 0,15 \times b</math> </p>	<p><b>8</b></p>

### 3.5 Slack adjuster attachments

#### Automatic slack adjuster ECO-Master, 5 / 91 - 10 / 00

9 / 97 - 5 / 03

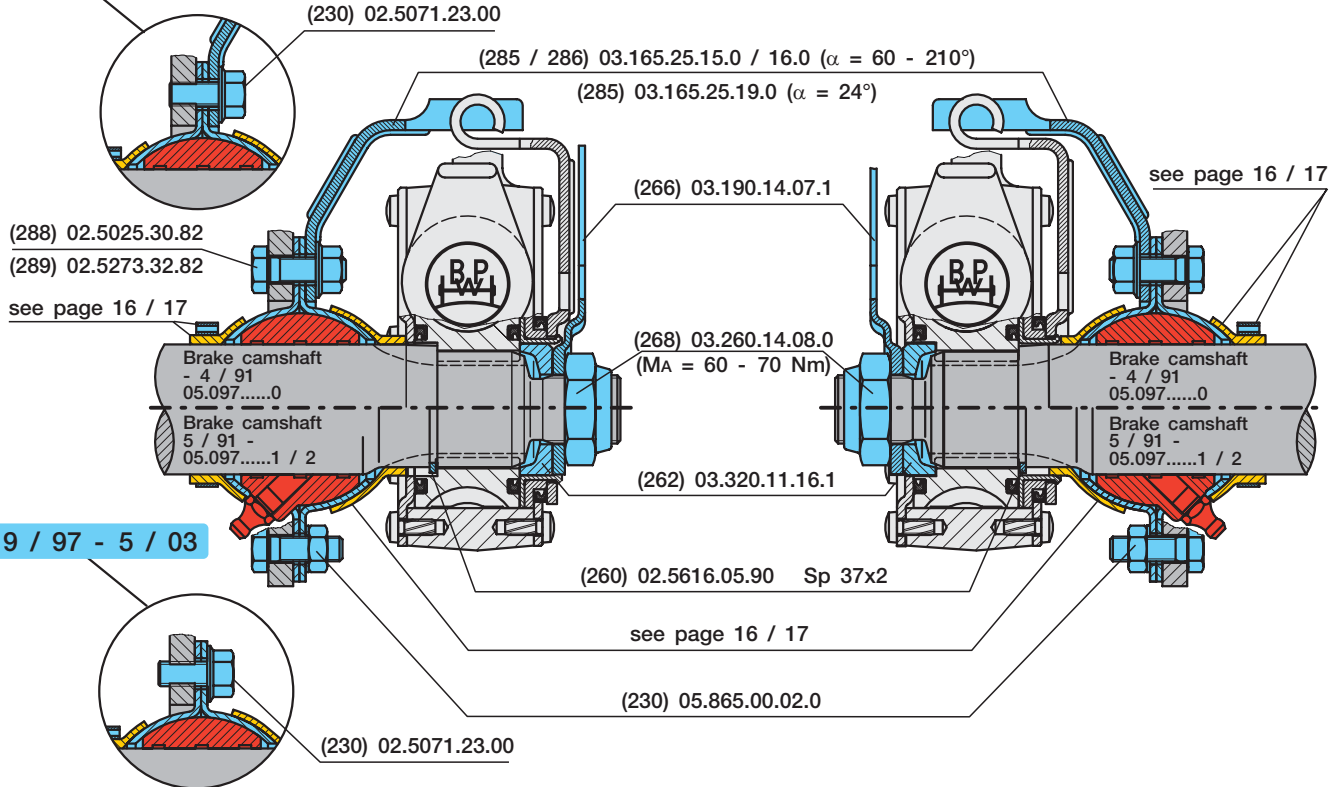

9 / 97 - 5 / 03

#### Automatic slack adjuster ECO-Master, 10 / 00 -

- 5 / 03

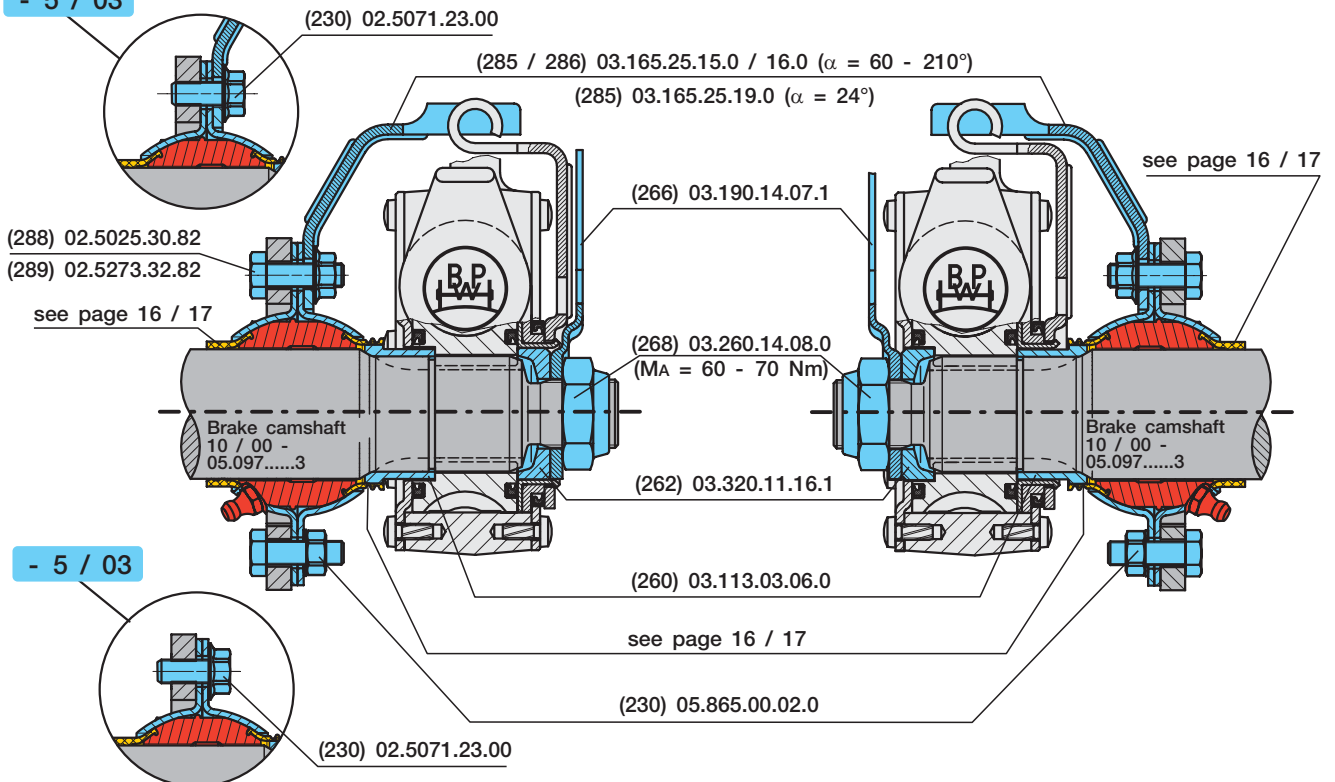

- 5 / 03

## Slack adjuster attachments 3.5

Item	Designation (Remark)	BPW Code no.	Dimension	
for ECO-Master ( autom. ) ( 5 / 91 - ) $\alpha = 60 - 210^\circ$				
285	Shaped plate	03.165.25.15.0		
286	Shaped plate	03.165.25.16.0		
288	Hexagon screw	02.5025.30.82	M 8 x 25 / 933	
289	Lock nut	02.5273.32.82	M 8	
for ECO-Master ( autom. ) ( 3 / 95 - 9 / 97 ) ( 6 / 03 - ) $\alpha = 24^\circ$				
285	Shaped plate	03.165.25.19.0		
288	Hexagon screw	02.5025.30.82	M 8 x 25 / 933	
289	Lock nut	02.5273.32.82	M 8	
for ECO-Master ( autom. ) ( 9 / 97 - 5 / 03 ) $\alpha = 24^\circ$				
285	Shaped plate	03.165.25.19.0		
230	Locking screw	02.5071.23.00	M 8 x 20	

**No longer available..  
Retrofit to hexagon screw  
with lock nut, see above.**

H

K

N

## 4 Brake parts

H

### General

#### BPW Drum brakes

The proven technology and robust construction of BPW drum brakes makes them suitable for every application. They shrug off dirt and are extremely hard wearing, even under the harshest conditions.

K

N

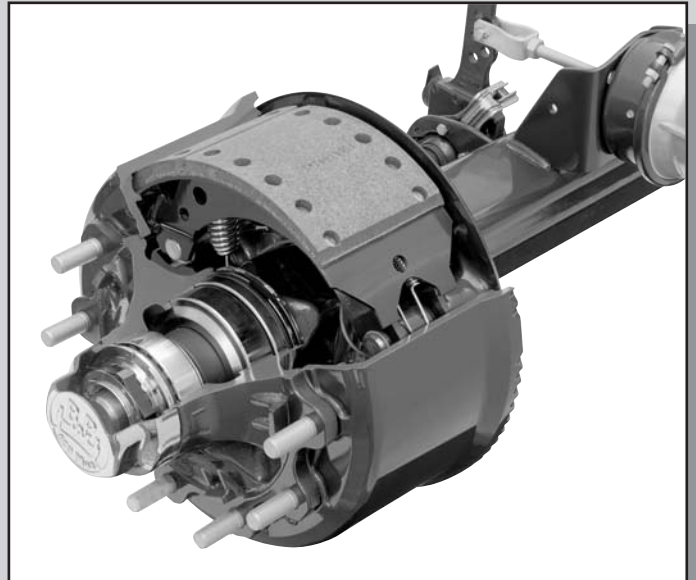

#### Function

The force from the brake cylinders is transmitted by the slack adjuster to the brake camshaft causing it to rotate.

The S-cam forces the brake shoes apart, pressing them against the inside of the brake drum.

When the brake is released, the brake camshaft rotates the S-cam back to its neutral position. The brake shoes are returned to their initial position by tension springs.

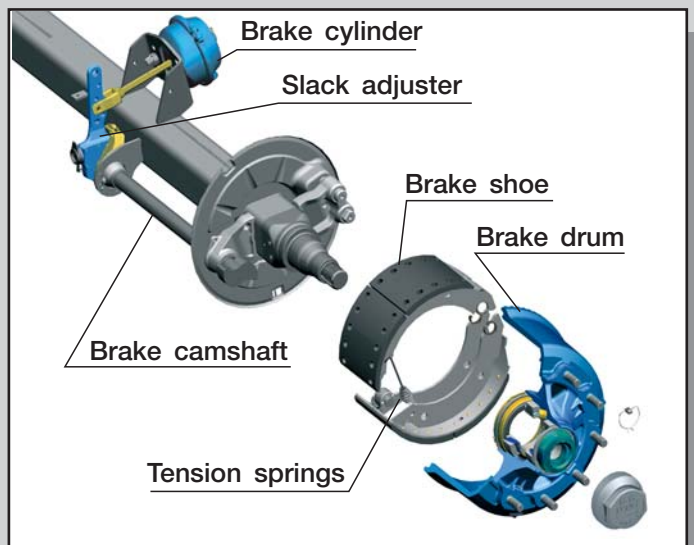

### Conversion to brake with splitted roller (BPW 95 brake)

Brakes of the former version should be changed over to new brake technology.

#### High degree of safety

Short response time and a consistent braking effect throughout the entire life of the lining thanks to the permanently lubricated brake rollers.

#### Reduced own weight

Weight-optimized design with fewer wear parts.

#### Easy to change brake linings

Fast and easy brake shoe replacement.

Same brake components on all axles of the corresponding series.

The technical specifications of the brake remain unchanged. Consequently existing EC test certificates remain valid.

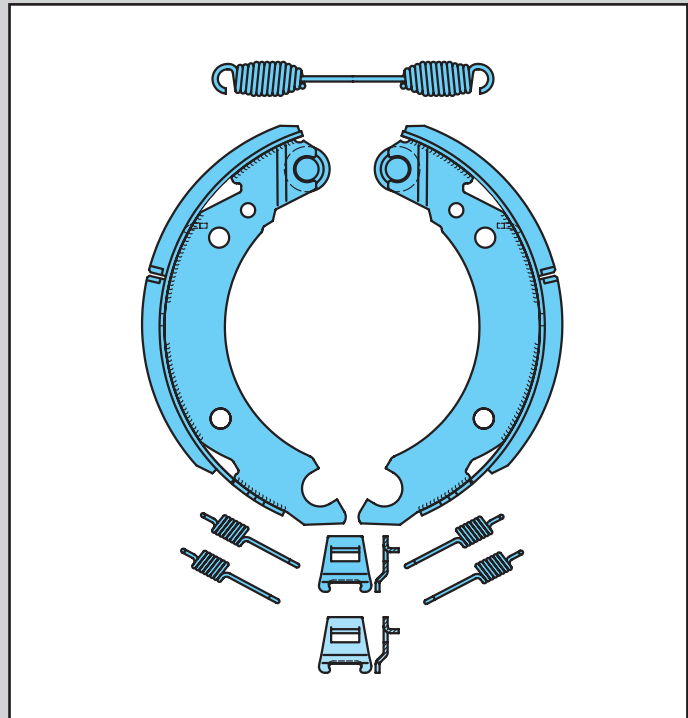

#### Position springs

The position springs ensure the brake shoes are firmly and securely seated on the C-clamps.

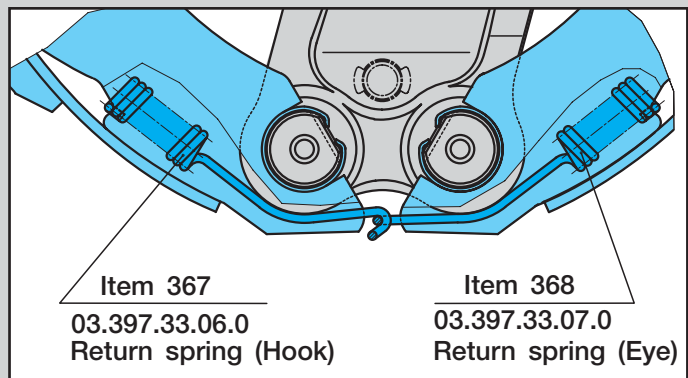

#### Brake pull-back springs

The brake pull-back spring is hooked into lugs that are formed on the brake shoes.

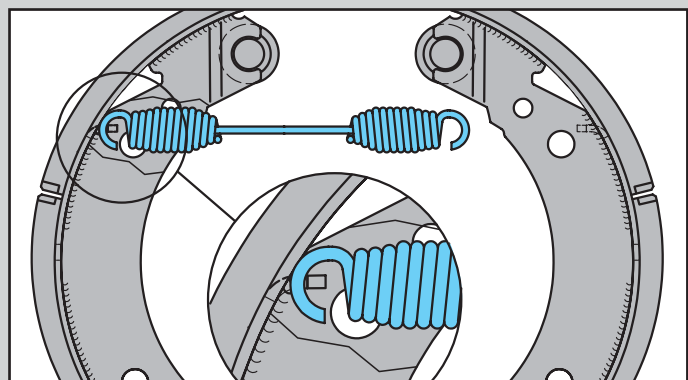

## 4.1 Brake parts

SN 42..-2

H

Conventional brake (Year of manufacture 1983 - 1995) H.. / R..  
 SN 4212-2 / 4218-2 / 4220-2 / 4222-2

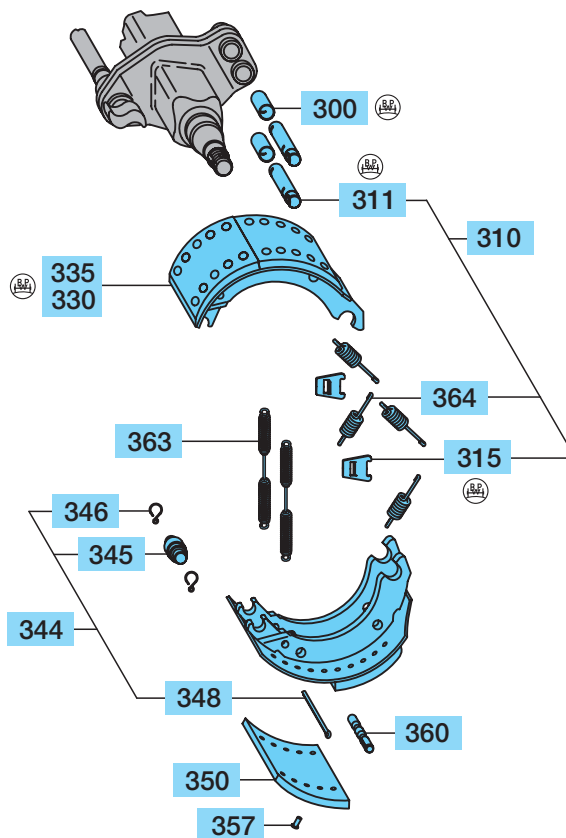

Conversion to brake with splitted roller (BPW 95) H.. / R..  
 SN 4212-2 / 4218-2 / 4220-2 / 4222-2

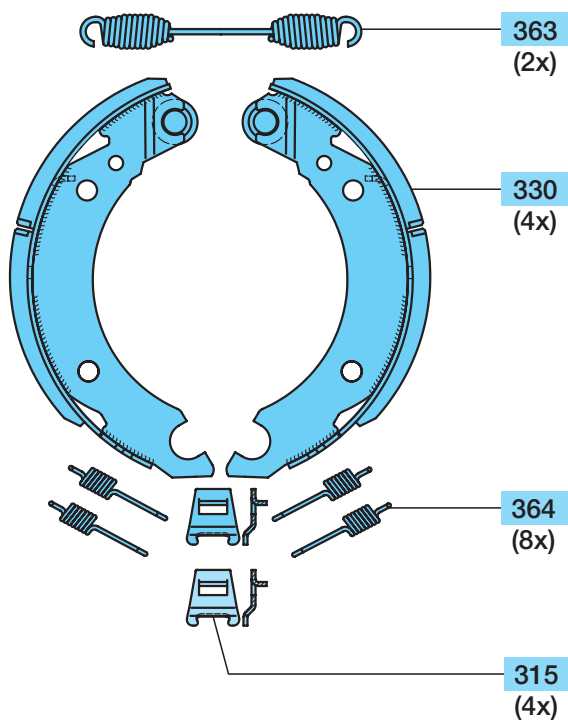

### Conversion to brake with splitted roller (BPW 95 brake)

- High degree of safety**  
Short response time and a consistent braking effect throughout the entire life of the lining thanks to the permanently lubricated brake rollers.
- Reduced own weight**  
Weight-optimized design with fewer wear parts.
- Easy to change brake linings**  
Fast and easy brake shoe replacement.
- Same brake components on all axles of the corresponding series**
- The technical specifications of the brake remain unchanged. Consequently existing EC test certificates remain valid.



# SN 42..-2

# Brake parts 4.1

Conventional brake (Year of manufacture 1983 - 1995)					H.. / R..
Item	Designation (Remark)	BPW Code no.	Dimension		
		SN 4212-2 SN 4218-2 SN 4220-2	---,---,790. / 794.--- ---,---,710. / 714.--- ---,---,718. / 723.---	SN 4222-2	---,---,739.---
300	Bush	03.112.33.08.0	Ø 36 / 40 x 60	03.112.33.08.0	Ø 36 / 40 x 60
310	Brake pin (cpl. item 311, 315)	09.084.46.36.0		09.084.46.35.0	
311	Brake pin	03.084.46.22.0	Ø 36 x 135	03.084.46.23.0	Ø 36 x 145
315	Shaped plate	03.167.23.02.0		03.167.23.02.0	
Brake type		SN 4212-2	SN 4218-2	SN 4220-2	SN 4222-2
330	Brake shoe assembly, with lining (incl. item 345 - 357)	05.091.29.84.0	05.091.46.09.0	05.091.27.79.0	05.091.28.26.0
335	Brake shoe assembly, without lining (incl. item 345 - 348)	05.091.29.51.0	05.091.26.64.2	05.091.27.54.2	05.091.28.11.2
344	Repair kit brake shoe roller (item 345 - 348)	-		09.801.02.10.0 (for 1 axle)	
345	Roller	Ø 26 / 42 x 52 Ø 26 / 42 x 78	03.331.34.06.0 -	- 03.331.34.05.0	
346	Circlip	03.350.00.13.0		03.350.00.13.0	
348	Split pin	6.3 x 71 / 94 6.3 x 90 / 94	02.6201.64.01 -	- 02.6201.66.03	
350	Brake lining (Textar T090)	18 mm 19 mm 19.5 mm 20 mm	03.092.29.53.0 03.092.29.54.0 03.092.29.55.0 -	03.092.27.76.0 03.092.27.77.0 - 03.092.27.78.0	03.092.28.32.0 03.092.28.33.0 - 03.092.28.34.0
360	Splined pin	Ø 12 x 70 Ø 12 x 90	03.001.08.04.0	- 03.001.08.05.0	
357	Rivet (Steel)	B 8 x 15/7338	02.5805.80.35	02.5805.80.35	
363	Return spring	Ø 25 / 5 x 269 Ø 25 / 4 x 262	05.397.58.07.0 (1x) -	- 05.397.46.07.0	
364	Return spring	Ø 21 / 4 x 105	03.397.44.06.0	03.397.44.06.0	

Conversion to brake with splitted roller (BPW 95)					H.. / R..
Item	Designation (Remark)	BPW Code no.	Dimension		
Brake type		SN 4212-2	SN 4218-2	SN 4220-2	SN 4222-2
328	Retrofit kit cpl. for 1 axle with brake shoes (item 315, 330, 363, 364)	09.801.02.94.0	09.801.02.39.0	09.801.02.38.0	09.801.02.53.0
329	Retrofit kit cpl. for 1 axle without brake shoes (item 315, 363, 364)	09.801.02.44.0	09.801.02.44.0	09.801.02.44.0	09.801.02.44.0
315	Shaped plate	03.167.23.09.0	03.167.23.09.0	03.167.23.09.0	03.167.23.09.0
330	Brake shoe assembly, with lining (incl. item 345 - 357)	05.091.29.92.0	05.091.46.14.0	05.091.27.82.0	05.091.28.28.0
345	Roller		05.331.44.02.0	Ø 26 / 45 x 33.5	
346	Bolt		03.084.75.24.0	Ø 26 x 58.5	
348	Ring		03.310.70.15.0	Ø 31 / 24 / 7	
350	Brake lining (Textar T090)	18 mm 03.092.29.53.0	03.092.26.85.0	03.092.27.76.0	03.092.28.32.0
357	Rivet (Steel)		02.5805.80.35	B 8 x 15 / 7338	
363	Return spring		05.397.58.03.0	Ø 34 / 5 x 274	
364	Return spring		03.397.44.06.0	Ø 21 / 4 x 105	

4.1 Brake parts

SN 36..

K

Conventional brake (Year of manufacture 1983 - 1995) KH.. / KR..

SN 3616

SN 3620

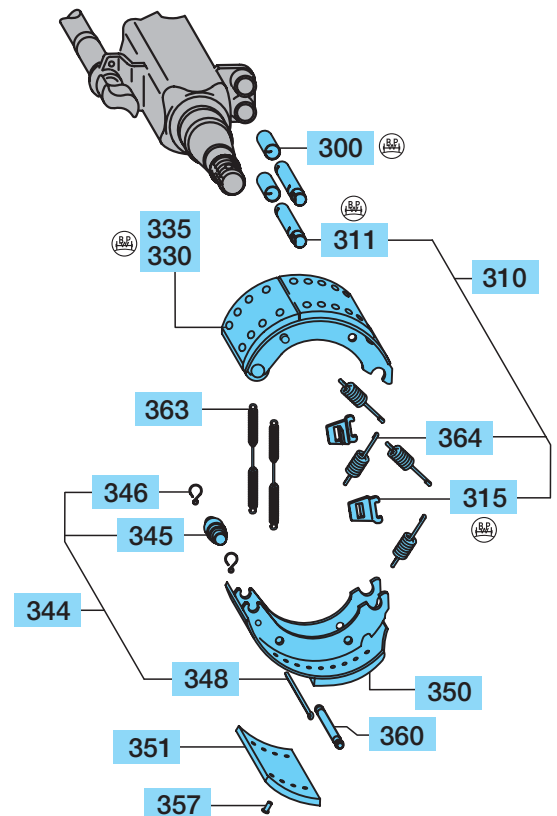
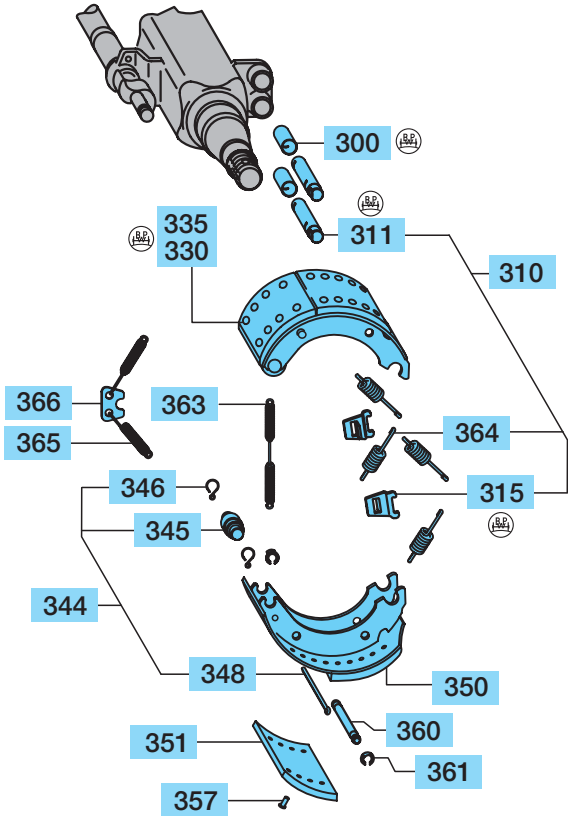

Conversion to brake with splitted roller (BPW 95) KH.. / KR..

SN 3616

SN 3620

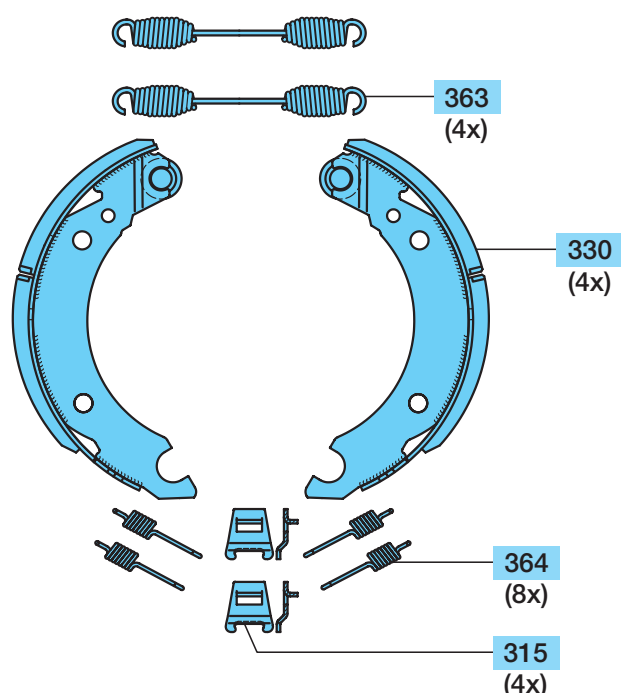
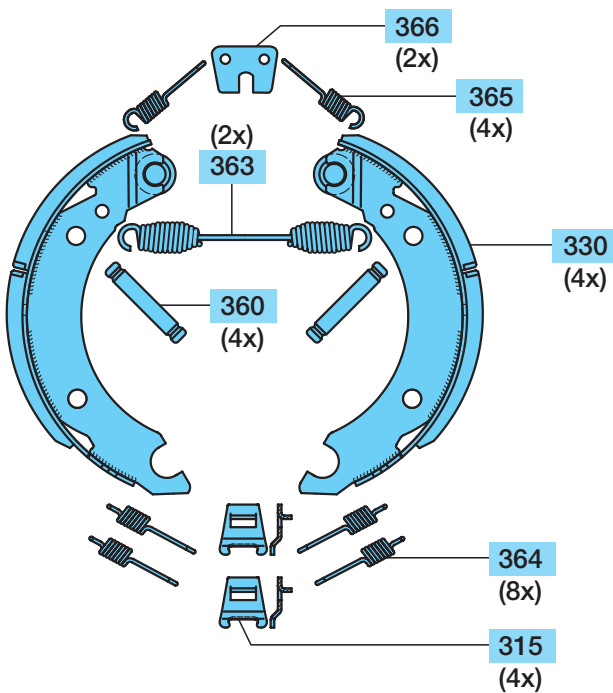

# SN 36..

# Brake parts 4.1

Conventional brake (Year of manufacture 1983 - 1995)				KH.. / KR..	
Item	Designation (Remark)		BPW Code no.		Dimension
			<b>SN 3616</b>	<b>--...542...--</b>	
			<b>SN 3620</b>	<b>--...546...--</b>	
300	Bush		03.112.33.08.0	Ø 36 / 40 x 60	
310	Brake pin (cpl. item 311, 315)		09.084.46.36.0		
311	Brake pin		03.084.46.22.0	Ø 36 x 135	
315	Shaped plate		03.167.23.02.0		
	<b>Brake type</b>		<b>SN 3616</b>	<b>--...542...--</b>	<b>SN 3620</b>
330	Brake shoe assembly, with lining (incl. item 345 - 357)		No longer available. Retrofit to brake with splitted roller		No longer available. Retrofit to brake with splitted roller
335	Brake shoe assembly, without lining (incl. item 345 - 348)		( BPW 95 ), (see below, item 328)		( BPW 95 ), (see below, item 328)
344	Repair kit brake shoe roller (item 345 - 348)		09.801.02.10.0 (for 1 axle)		
345	Roller		03.331.34.05.0	Ø 26 / 42 x 78	
346	Circlip		03.350.00.13.0		
348	Split pin		02.6201.66.03	6.3 x 90 / 94	
			<b>Brake pin side</b>	<b>Camshaft side</b>	<b>Brake pin side</b>
			<b>10 Rivets</b>	<b>8 Rivets</b>	<b>10 Rivets</b>
			<b>item 350</b>	<b>item 351</b>	<b>item 350</b>
350	Brake lining	18 mm	<b>03.092.19.63.0</b>	<b>03.092.19.62.0</b>	<b>03.092.19.54.0</b>
351	(Textar T090)	19 mm	03.092.19.64.0	03.092.19.65.0	03.092.19.56.0
		19.5 mm	03.092.19.66.0	03.092.19.67.0	03.092.19.58.0
357	Rivet (Steel)		02.5805.80.35 B 8 x 15 / 7338		
360	Bolt		03.084.42.03.0	Ø 12 x 120	03.084.42.02.0
361	Circlip		02.3317.17.00	12 SxN 09	-
363	Return spring		05.397.45.14.0 Ø 24 / 4 x 218		
364	Return spring		03.397.44.06.0 Ø 21 / 4 x 105		
365	Return spring		03.397.45.10.0	Ø 22 / 4 x 108	-
366	Plate		03.285.22.05.0		

Conversion to brake with splitted roller (BPW 95)				KH.. / KR..	
Item	Designation (Remark)		BPW Code no.		Dimension
	<b>Brake type</b>		<b>SN 3616</b>	<b>SN 3620</b>	
328	Retrofit kit cpl. for 1 axle with brake shoes (item 315, 330, 360 - 366)		<b>09.801.02.41.0</b>	<b>09.801.02.40.0</b>	
329	Retrofit kit cpl. for 1 axle without brake shoes (item 315, 360 - 366)		09.801.02.46.0	09.801.02.45.0	
315	Shaped plate		03.167.23.09.0		
330	Brake shoe assembly, with lining (incl. item 345 - 357)		05.091.19.24.0	05.091.19.22.0	
345	Roller		05.331.44.02.0	Ø 26 / 45 x 33.5	
346	Bolt		03.084.75.24.0 Ø 26 x 58.5		
348	Ring		03.310.70.15.0 Ø 31 / 24 / 7		
			<b>Brake pin side</b>	<b>Camshaft side</b>	<b>Brake pin side</b>
			<b>10 Rivets</b>	<b>8 Rivets</b>	<b>10 Rivets</b>
			<b>item 350</b>	<b>item 351</b>	<b>item 350</b>
350	Brake lining	18 mm	03.092.19.63.0	03.092.19.62.0	03.092.19.54.0
357	Rivet (Steel)		02.5805.80.35 B 8 x 15 / 7338		
360	Bolt		03.084.42.05.0	Ø 12 x 125	-
363	Return spring		05.397.46.13.0 Ø 24.5 / 4 x 236		
364	Return spring		03.397.44.06.0 Ø 21 / 4 x 105		
365	Return spring		03.397.45.10.0	Ø 22 / 4 x 108	-
366	Plate		03.285.22.05.0		

4.1 Brake parts

SN 30..

Conventional brake (Year of manufacture 1982 - 1995) NH.. / NR..

SN 3015-1 / 3020-1,  
Brake shoes with closed anchor eye  
1982 - 1989

SN 3015 / 3020,  
Quick-release brake shoes  
1990 - 1995

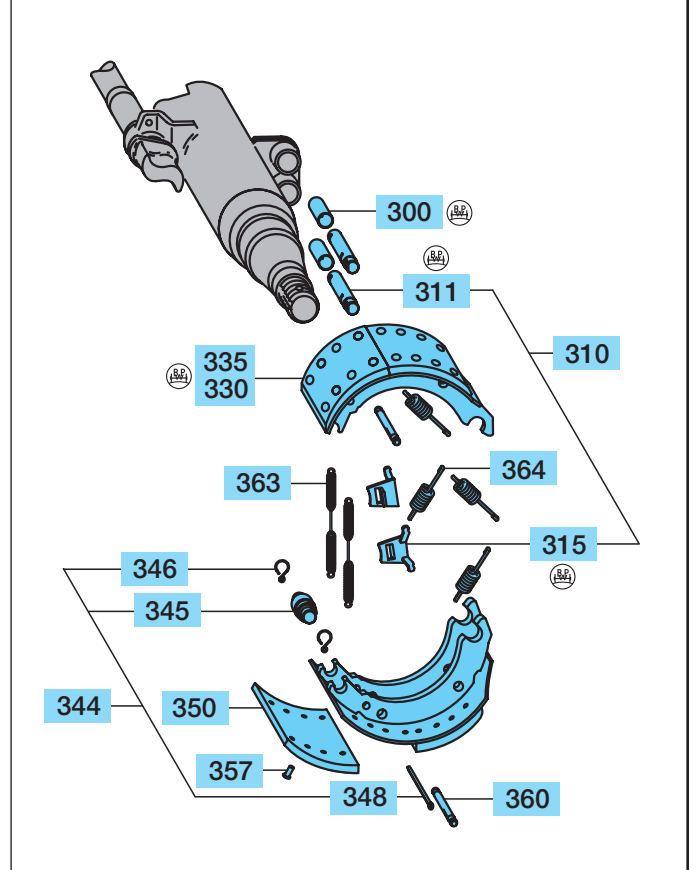
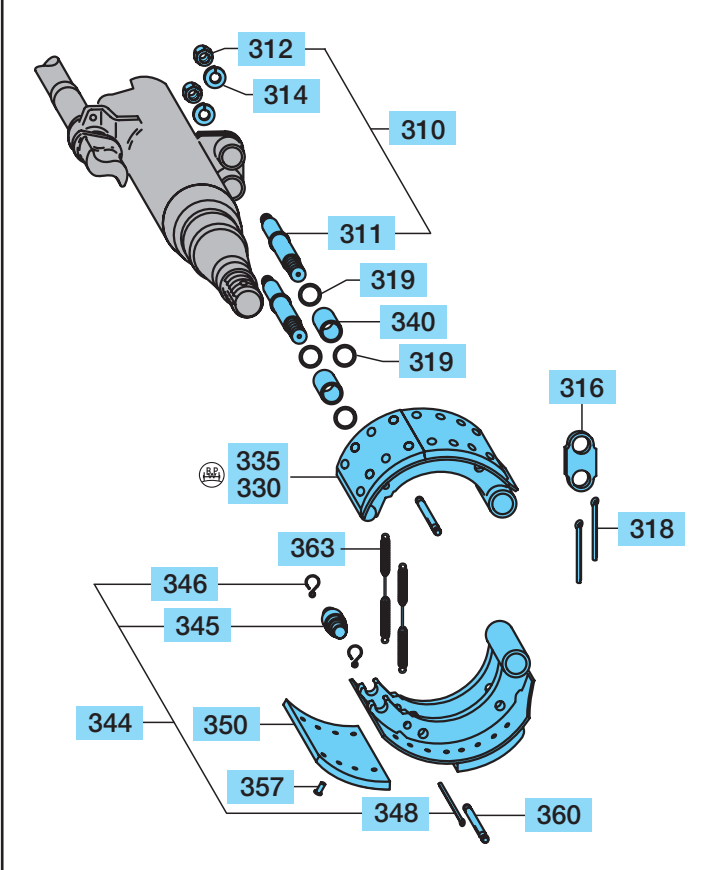

Conversion to brake with splitted roller (BPW 95) NH.. / NR..

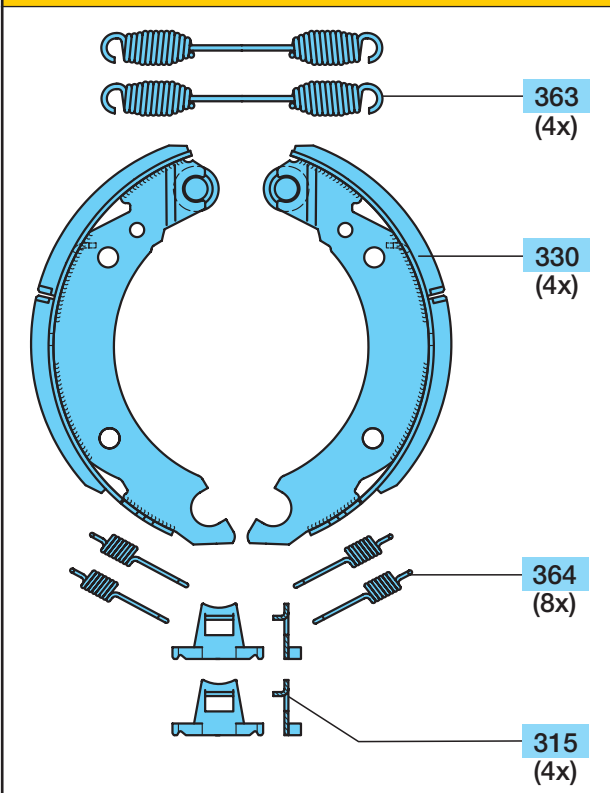

Brake type		SN 3015	SN 3020
Item	Designation (Remark)	BPW Code no.	BPW Code no.
328	Retrofit kit cpl. for 1 axle with brake shoes (item 315, 330, 363, 364)	09.801.02.43.0	09.801.02.42.0
329	Retrofit kit cpl. for 1 axle without brake shoes (item 315, 363, 364)	09.801.02.47.0	09.801.02.47.0
315	Shaped plate	03.167.24.01.0	
330	Brake shoe assembly with lining (incl. item 345 - 357)	05.091.15.05.0	05.091.14.77.0
345	Roller	05.331.44.02.0	Ø 26 / 45 x 33.5
346	Bolt	03.084.75.24.0	Ø 26 x 58.5
348	Ring	03.310.70.15.0	Ø 31 / 24 / 7
350	Brake lining (Textar T090) 18 mm	03.092.13.44.0	03.092.14.45.0
357	Rivet (Steel)	02.5805.80.35	B 8 x 15 / 7338
363	Return spring	05.397.34.17.0	Ø 20 / 3.5 x 180
364	Return spring	03.397.44.06.0	Ø 21 / 4 x 105

# SN 30..

# Brake parts 4.1

Conventional brake (Year of manufacture 1982 - 1995)				NH.. / NR..	
Item	Designation (Remark)	BPW Code no.	Dimension		
		<b>SN 315-1 * / SN 3020-1 *</b> <b>Brake shoes with closed anchor eye</b> <b>---.---.582. / 586.---</b> <b>(old type) 1982 - 1989</b>		<b>SN 3015 / SN 3020</b> <b>Quick-release brake shoes</b> <b>---.---.592. / 596.---</b> <b>1990 - 1995</b>	
300	Bush	-		03.112.33.08.0	Ø 36 / 40 x 60
310	Thread bolt cpl. (cpl. item 311, 314, 315)	09.177.23.09.0		-	
310	Brake pin cpl. (item 311, 315)	-		09.084.46.39.0	
311	Brake pin	-		03.084.46.30.0	Ø 36 x 145 (135)
311	Thread bolt	03.177.23.10.0	Ø 32 / 38 x 153	-	
312	Hexagon nut	02.5201.76.06	BM 20 x 1.5 / 439	-	
314	Spring washer	03.143.00.02.0	Ø 22.5 / 34 / 80°	-	
315	Shaped plate	-		03.167.24.01.0	
316	Shackle (standard) (for ABS, brake drum width until 260 mm)	<b>03.232.44.02.0</b> 03.232.44.04.0		-	
318	Split pin	02.6201.80.01	8 x 45 / 94	-	
319	'O'-Ring	02.5677.86.40	Ø 28 x 2.5	-	
	<b>Brake type</b>	<b>SN 3015-1 *</b>	<b>SN 3020-1 *</b>	<b>SN 3015</b>	
		<b>NR.. ○ 127</b> <b>---.---.582.---</b>	<b>NR.. ○ 127</b> <b>---.---.586.---</b>	<b>NR.. ○ 127</b> <b>---.---.592.---</b>	<b>NH.. □ 120</b> <b>---.---.592.---</b>
		<b>NR.. ○ 127</b> <b>---.---.596.---</b>	<b>NH.. □ 120</b> <b>---.---.596.---</b>		
330	Brake shoe assembly, with lining (incl. item 345 - 357)	05.091.13.85.0	05.091.14.70.0	No longer available. Retrofit to brake with splitted roller	
335	Brake shoe assembly, without lining (incl. item 345 - 348)	05.091.13.20.0	05.091.14.19.0	(BPW 95 ), (see page 36, item 328)	
340	Bush	03.112.22.30.0	Ø 32 / 36x54	-	
344	Repair kit brake shoe roller (item 345 - 348)	09.801.02.11.0	(for 1 axle)	09.801.02.12.0	(for 1 axle)
345	Roller	03.331.34.01.0	Ø 22 / 42x59	03.331.34.01.0	Ø 22 / 42 x 59
346	Shackle	03.232.13.01.0		-	
346	Circlip	-		03.350.00.14.0	
348	Split pin	02.6201.83.03	Ø 8 x 71/94	02.6201.66.03	Ø 6.3 x 90 / 94
350	Brake lining 18 mm (Textar T090) 19 mm 19.5 mm	<b>03.092.13.44.0</b> 03.092.13.45.0 03.092.13.46.0	<b>03.092.14.45.0</b> 03.092.14.46.0 03.092.14.47.0	<b>03.092.13.44.0</b> 03.092.13.45.0 03.092.13.46.0	
357	Rivet (Steel)	02.5805.80.35	B 8 x 15/7338	02.5805.80.35	B 8 x 15/7338
360	Splined pin	03.001.08.03.0	Ø 12 x 70	03.001.08.05.0	Ø 12 x 90
363	Return spring	05.397.35.03.0	Ø 22/3.6x163	-	
	Ø 24/4x167	-		05.397.46.12.0	-
	Ø 20/3.6x166	-		-	05.397.34.16.0
364	Return spring	-		03.397.44.06.0	Ø 21 / 4 x 105
<p>* Brake shoes with closed location eyes (Execution ....-1) can not be fitted to brake with splitted roller (BPW 95).</p>					

N

4.2 Brake parts

SN 42.. with splitted roller (BPW 95)

Brake with splitted roller (BPW 95) (Manufactured from 3/95)

H.. / R..

SN 42.. BPW 95

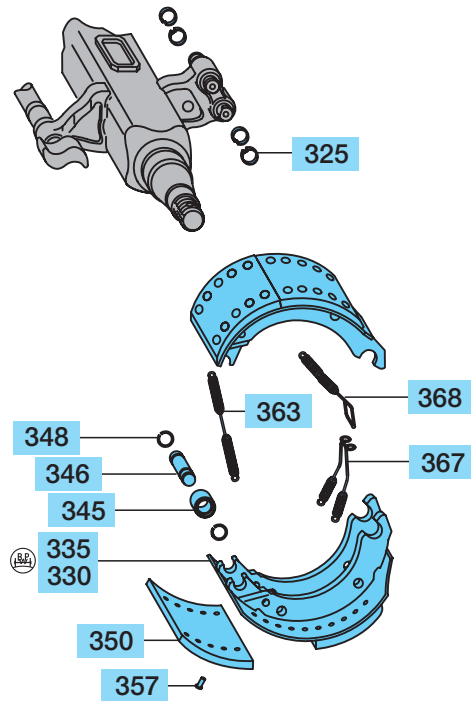

# SN 42.. with splitted roller (BPW 95)

# Brake parts 4.2

Brake with splitted roller (BPW 95) (Manufactured from 3/95)					H.. / R..	
Item	Designation (Remark)	BPW Code no.	Dimension			
			SN 4212 ---.741.---	SN 4218 ---.743.---	SN 4220 ---.744.---	SN 4222 ---.745.---
324	Repair kit brake (item 325, 330, 363 - 368)	-	09.801.02.83.0	09.801.02.84.0	09.801.02.85.0	
325	'C' Clip		03.188.02.02.0			
327	Repair kit brake, without brake shoes (item 325, 363, 367, 368)		09.801.06.79.0			
328	Repair kit brake, with brake shoes (item 325, 330, 363, 367, 368)	-	09.801.02.39.0	09.801.02.38.0	09.801.02.53.0	
330	Brake shoe assembly, with lining, (incl. item 345 - 357)	05.091.29.92.0	05.091.46.14.0	05.091.27.87.0	05.091.28.28.0	
335	Brake shoe assembly, without lining, (incl. item 345 - 348)	05.091.29.93.0	05.091.46.17.0	05.091.27.83.0	05.091.28.29.0	
344	Repair kit brake shoe roller (item 345 - 348)		09.801.02.91.0 (for 1 axle side)			
345	Roller		05.331.44.02.0	Ø 26 / 45 x 33.5		
346	Bolt		03.084.75.24.0	Ø 26 x 58.5		
348	Ring		03.310.70.15.0	Ø 24 / 31 / 7		
350	Brake lining (Textar T090)	18 mm 19 mm 19.5 mm 20 mm	03.092.29.53.0 03.092.29.54.0 03.092.29.55.0 -	03.092.26.85.0 03.092.26.86.0 - 03.092.26.87.0	03.092.27.76.0 03.092.27.77.0 - 03.092.27.78.0	03.092.28.32.0 03.092.28.33.0 - 03.092.28.34.0
357	Rivet (Steel)		02.5805.80.35	B 8 x 15 / 7338		
363	Return spring		05.397.58.03.0	Ø 34 / 5 x 268		
367	Return spring (Retention spring)		03.397.33.06.0	(Hook)		
368	Return spring (Retention spring)		03.397.33.07.0	(Eye)		

4.2 Brake parts

SN 36.. with splitted roller (BPW 95)

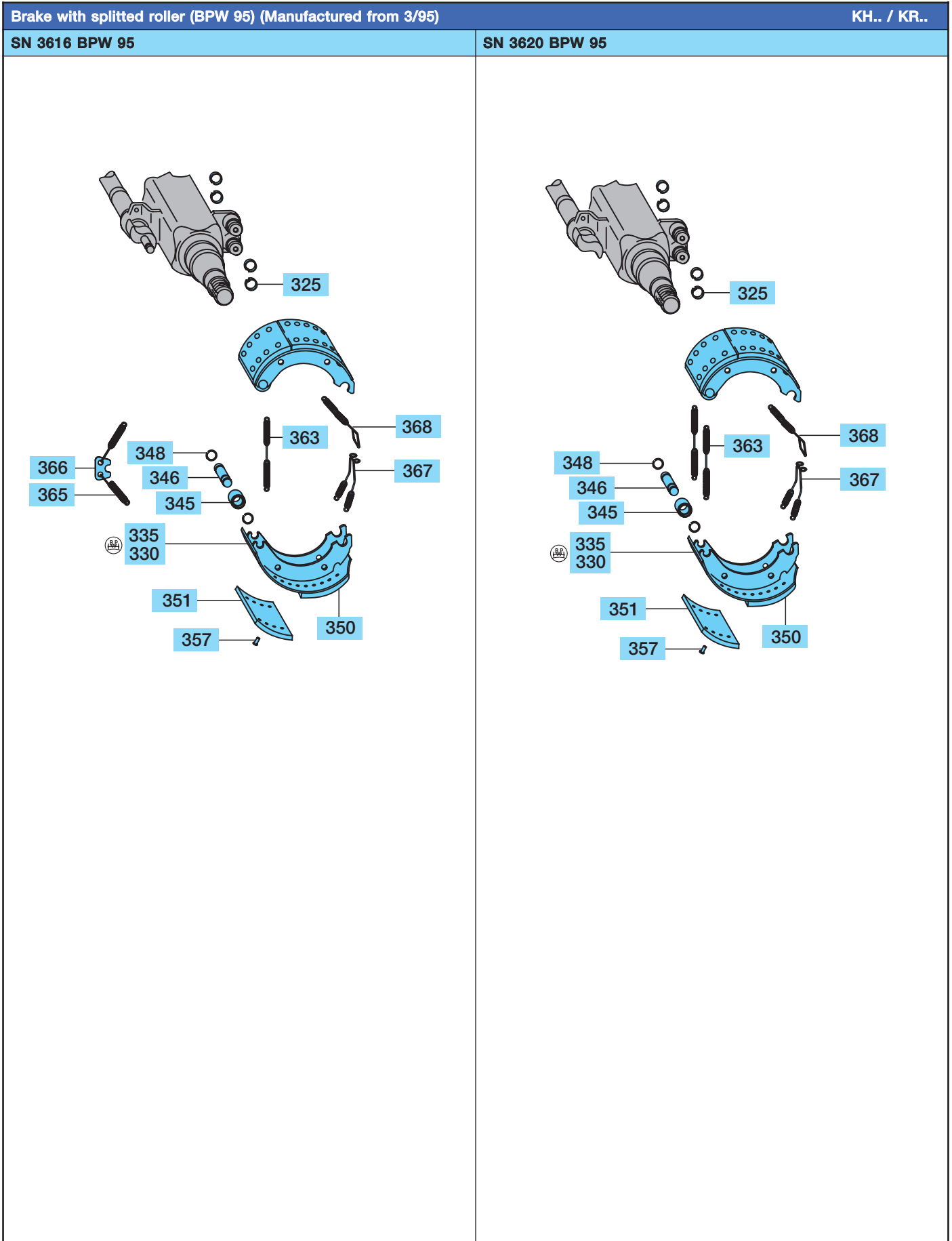

K



# SN 36.. with splitted roller (BPW 95)

# Brake parts 4.2

Brake with splitted roller (BPW 95) (Manufactured from 3/95)					KH.. / KR..	
Item	Designation (Remark)		BPW Code no.	Dimension		
Brake type Brake designation			SN 3616 ---.---.551.---	SN 3620 ---.---.552.---		
325	'C' Clip			03.188.02.02.0		
327	Repair kit brake without brake shoes (item 325, 363, 365, 367, 368)		09.801.06.82.0	09.801.06.81.0		
328	Repair kit brake, with brake shoes (item 325, 330, 363, 365, 367, 368)		<b>09.801.02.41.0</b>	<b>09.801.02.40.0</b>		
330	Brake shoe assembly, with lining, (incl. item 345 - 357)		05.091.19.24.0	05.091.19.22.0		
335	Brake shoe assembly, without lining, (incl. item 345 - 348)		05.091.19.33.0	05.091.19.34.0		
344	Repair kit brake shoe roller (item 345 - 348)			09.801.02.91.0 (for 1 axle side)		
345	Roller			05.331.44.02.0	Ø 26 / 45 x 33.5	
346	Bolt			03.084.75.24.0	Ø 26 x 58.5	
348	Ring			03.310.70.15.0	Ø 24 / 31 / 7	
			<b>Brake pin side 10 Rivets item 350</b>	<b>Camshaft side 8 Rivets item 351</b>	<b>Brake pin side 10 Rivets item 350</b>	<b>Camshaft side 8 Rivets item 351</b>
350	Brake lining	18 mm 19 mm 19.5 mm	03.092.19.63.0 03.092.19.64.0 03.092.19.66.0	03.092.19.62.0 03.092.19.65.0 03.092.19.67.0	03.092.19.54.0 03.092.19.56.0 03.092.19.58.0	03.092.19.55.0 03.092.19.57.0 03.092.19.59.0
357	Rivet (Steel)			02.5805.80.35	B 8 x 15 / 7338	
363	Return spring			05.397.46.13.0	Ø 24.5 / 4 x 236	
365	Return spring		03.397.44.10.0	Ø 22 / 4 x 119	-	
366	Plate		03.285.22.05.0		-	
367	Return spring (Retention spring)			03.397.33.06.0	(Hook)	
368	Return spring (Retention spring)			03.397.33.07.0	(Eye)	

K

4.2 Brake parts

SN 30.. with splitted roller (BPW 95)

Brake with splitted roller (BPW 95) (Manufactured from 3/95)

NH.. / NR..

SN 30.. BPW 95

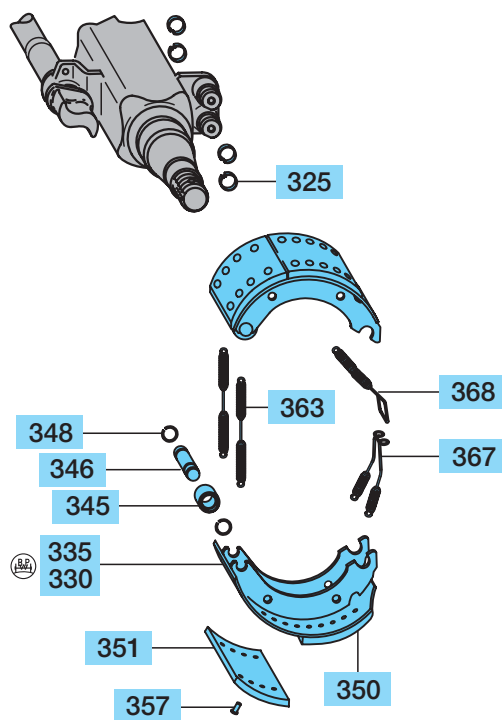

N

# SN 30.. with splitted roller (BPW 95)

# Brake parts 4.2

Brake with splitted roller (BPW 95) (Manufactured from 3/95)			NH.. / NR..	
Item	Designation (Remark)	BPW Code no.	Dimension	
	<b>Brake type</b>	<b>SN 3015</b>	<b>SN 3020</b>	
	<b>Brake designation</b>	<b>---,---,501,---</b>	<b>---,---,502,---</b>	
325	'C' Clip		03.188.02.02.0	
327	Repair kit brake, without brake shoes (item 325, 363, 365, 367, 368)		09.801.06.80.0	
328	Repair kit brake, with brake shoes (item 325, 330, 363, 365, 367, 368)	<b>09.801.02.43.0</b>	<b>09.801.02.42.0</b>	
330	Brake shoe assembly, with lining, (incl. item 345 - 357)	05.091.15.05.0	05.091.14.77.0	
335	Brake shoe assembly, without lining, (incl. item 345 - 348)	05.091.15.13.0	05.091.14.80.0	
344	Repair kit brake shoe roller (item 345 - 348)		09.801.02.91.0 (for 1 axle side)	
345	Roller		05.331.44.02.0	Ø 26 / 45 x 33.5
346	Bolt		03.084.75.24.0	Ø 26 x 58.5
348	Ring		03.310.70.15.0	Ø 24 / 31 / 7
350	Brake lining 18 mm (Textar T090) 19 mm 19.5 mm	<b>03.092.13.44.0</b> 03.092.13.45.0 03.092.13.46.0	<b>03.092.14.45.0</b> 03.092.14.46.0 03.092.14.47.0	
357	Rivet (Steel)		02.5805.80.35	B 8 x 15 / 7338
363	Return spring		05.397.34.17.0	Ø 20 / 3.6 x 180
367	Return spring (Retention spring)		03.397.33.08.0	(Hook)
368	Return spring (Retention spring)		03.397.33.09.0	(Eye)

N

## 4.3 Brake drums

Item	Designation (Remark)	BPW Code no.		Dimension		H. / R..	
<b>SN 42..</b>							
280	Brake drum						
	<b>Brake type</b>	<b>Ø 420 x 120 B</b>	<b>Ø 420 x 180 B</b>	<b>Ø 420 x 200 B</b>	<b>Ø 420 x 220 B</b>		
	<b>Brake designation</b>	---,741.---	---,710.---	---,718.---	---,739.---		
		---,790.---	---,714.---	---,723.---	---,745.---		
		---,794.---	---,743.---	---,744.---			
	<b>D 290 / TK 335 / 6 x Ø21</b>						
	<b>HB.. / HI.. / HX..</b>	03.106.97.16.0 197	03.109.67.17.0 226	03.109.77.13.0 260	-		
		-	03.109.67.01.0 252	03.109.77.03.0 287	-		
	<b>HIZ. / HXZ..</b>	-	03.109.67.17.0 226	03.106.77.56.0 247	03.106.87.16.0 265		
	<b>D 230 / TK 275 / 8 x Ø21</b>						
	<b>HS.. / HZ.. / HZD..</b>	03.106.95.16.0 197	03.106.65.08.0 252	03.109.77.09.0 287	-		
	<b>D 230 / TK 275 / 8 x Ø23</b>						
	<b>HS.. ECO / ECO-MAXX</b>	03.109.73.02.0 197	-	-	-		
	<b>D 240 / TK 285 / 8 x Ø21</b>						
	<b>HZ.. Japanese</b>	-	-	03.109.77.28.0 287	-		
	<b>D 240 / TK 285 / 8 x Ø21</b>						
	<b>HZ.. Japanese</b>	-	03.109.67.05.0 252	03.106.79.06.0 287 *	-		
	<b>D 240 / TK 285 / 8 x Ø20</b>						
	<b>HZ.. Japanese</b>	-	-	-	03.109.87.03.0 294		
	<b>D 240 / TK 285 / 10 x Ø21</b>						
	<b>HZ.. Japanese</b>	-	03.109.67.06.0 252	03.109.77.02.0 287	-		
	<b>D 290 / TK 335 / 10 x Ø23</b>						
	<b>HS..</b>	-	<b>03.109.67.13.0 226</b>	<b>03.109.77.16.0 260</b>	-		
	<b>HS.. ECO MAXX / MAXX / ECOPlus</b>	03.109.73.01.0 197	<b>03.109.67.19.0 226</b>	<b>03.109.77.17.0 259</b>	-		
		-	03.109.67.27.0 226 *	-	-		
	<b>HZ.. ECO MAXX / MAXX / ECOPlus</b>	-	<b>03.109.67.21.0 249</b>	<b>03.109.77.18.0 287</b>	-		
	<b>HS.. / HZ..</b>	03.106.97.17.0 197	<b>03.109.67.74.0 252</b>	<b>03.109.77.72.0 287</b>	03.106.87.12.0 294		
		-	-	-	03.109.87.01.0 294		
	<b>HZ.. for rim 14.00-20</b>	-	-	03.106.77.61.0 287	-		
	<b>HZ.. MAXX for rim 14.00-20</b>	-	-	03.109.77.23.0 284	-		
		-	-	03.109.77.24.0 284 *	-		
	<b>HZ.. 14010-1</b>	-	-	03.106.77.63.0 297 *	-		
		-	-	03.106.77.59.0 297	-		
	<b>HZ.. 14010-1 MAXX</b>	-	-	03.109.77.21.0 294	-		
		-	-	03.109.77.22.0 294 *	-		
	<b>HZD..</b>	03.106.97.17.0 197	03.106.67.55.0 252 *	03.106.77.53.0 287 *	-		
	<b>Max. diameter permissible after machining Ø mm</b>	<b>423</b>	<b>424</b>	<b>424</b>	<b>424</b>		
	<b>Max. utilisation Ø mm</b>	424	425.5	425.5	425.5		

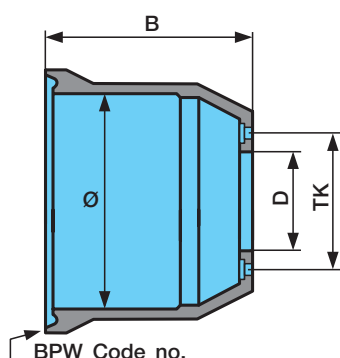

B = overall width

\* = ribbed

**03.109....=** ECO brake drum with integrated wear indicator

## Brake drums 4.3

Item	Designation (Remark)	BPW Code no.	Dimension	
<b>SN 36..</b>				<b>KH.. / KR..</b>
280	Brake drum			
	<b>Brake type</b>	<b>Ø 360 x 160 B</b>	<b>Ø 360 x 200 B</b>	
	<b>Brake designation</b>	---.542.---	---.546.---	
		---.551.---	---.552.---	
	<b>D 230 / TK 275 / 8 x Ø23 / 2 x Ø11</b>			
	KRBM.. 6408 30.65.542....	03.105.90.05.0 221	-	
	<b>D 230 / TK 275 / 8 x Ø23</b>			
	KRB.. 30.06.542....	03.105.90.09.0 328	-	
	<b>D 230 / TK 275 / 8 x Ø23</b>			
	K.. ECO-MAXX / ECOPlus	-	<b>03.109.90.03.0 260</b>	
		-	<b>03.109.90.22.0 263</b>	
	<b>D 190 / TK 225 / 10 x Ø23</b>			
	K.. ECO-MAXX / ECOPlus	-	<b>03.109.90.04.0 260</b>	
	KH.. / KR.. / KM (13t)	-	<b>03.109.90.24.0 263</b>	
	<b>D 290 / TK 335 / 10 x Ø23</b>			
	KHS.. 9010/3 / 11010/3	-	03.109.90.02.0 263	
	<b>D 290 / TK 335 / 10 x Ø23</b>			
	KHS.. 9010 / 3 30.38.551...	03.109.92.01.0 205	-	
	<b>Max. diameter permissible after machining Ø mm</b>	<b>363</b>	<b>363</b>	
	<b>Max. utilisation Ø mm</b>	<b>364</b>	<b>364</b>	

<b>SN 30..</b>				<b>NH.. / NR..</b>
280	Brake drum			
	<b>Brake type</b>	<b>Ø 300 x 150 B</b>	<b>Ø 300 x 200 B</b>	
	<b>Brake designation</b>	---.582.---	---.586.---	
		---.592.---	---.552.---	
		---.501.---	---.502.---	
	<b>D 165 / TK 205 / 6 x Ø 21</b>			
	N..	03.105.34.08.0 210	03.109.46.01.0 295	
	<b>D 165 / TK 205 / 6 x Ø23 / 2 x Ø11</b>			
	N.. 12" tyres	03.105.34.09.0 345 <sup>1)</sup>	-	
	<b>D 190 / TK 230 / 6 x Ø21</b>			
	N..IZ / N..XZ	03.105.34.10.0 210	03.105.47.05.0 255	
	<b>D 200 / TK 240 / 6 x Ø21 / 2 x Ø13</b>			
	N..IZ / N..XZ 13 t	-	03.105.48.02.0 255	
	<b>D 230 / TK 275 / 8 x Ø21 / 2 x Ø11</b>			
	N.. 8-holes	03.105.38.03.0 210	03.105.49.03.0 295	
	N.. 8-holes	03.105.38.01.0 328	-	
	<b>D 230 / TK 275 / 8 x Ø23</b>			
	N.. 8-holes	03.105.38.05.0 210	-	
	<b>D 185 / TK 225 / 10 x Ø23 / 2 x Ø13</b>			
	N.. 13 t 10-holes	-	<b>03.105.46.25.0 265</b>	
	N.. 13 t 10-holes	-	<b>03.105.46.27.0 315</b>	
	<b>D 190 / TK 225 / 10 x Ø23</b>			
	N.. Conv. / ECO	03.105.36.12.0 210	03.105.46.22.0 245	
	N.. Conv. / ECO	-	<b>03.109.46.49.0 260</b>	
	N.. ECO-MAXX / MAXX	03.109.44.02.0 210	<b>03.109.46.06.0 260</b>	
	N.. Conv. / ECO	-	<b>03.109.46.40.0 295</b>	
	<b>Max. diameter permissible after machining Ø mm</b>	<b>303</b>	<b>303</b>	
	<b>Max. utilisation Ø mm</b>	<b>304</b>	<b>304</b>	

<sup>1)</sup> + Cylinder peg for wheel stud bolt securing 4 x 16 / 1472, BPW Code no. 02.6004.06.01

### 4.4 Brake drum attachments

Item	Designation (Remark)	BPW Code no.	Dimension	
<b>HB..</b>				
390	Screw assembly (incl. item 391 + 392)	05.865.03.12.0	M 20x55-8.8	
391	Spring washer	02.5601.20.90	A 20/128	
392	Hexagon nut	02.5202.24.80	M 20/934	

<b>HI.. / HIZ..</b>				
390	Screw assembly (incl. item 392)	05.865.03.02.0	M 20x45-10.9	
392	Lock nut	03.260.03.12.0	M 20-10/SW30	

<b>KRBM.. 6408</b>				
390	Locking screw	02.5070.63.02	M 10x25	

## Brake drum attachments 4.4

Item	Designation (Remark)	BPW Code no.	Dimension	
<b>NR.. 6006 12" and NR.. 8-holes</b>				
390	Locking screw	02.5070.63.00	M 10x25	
<b>NR 13 t..</b>				
390	Countersunk screw	02.5002.20.40	M 12x25/963-4.8	

N

4.5 Dust covers

Dust covers available as sets (upper + lower)

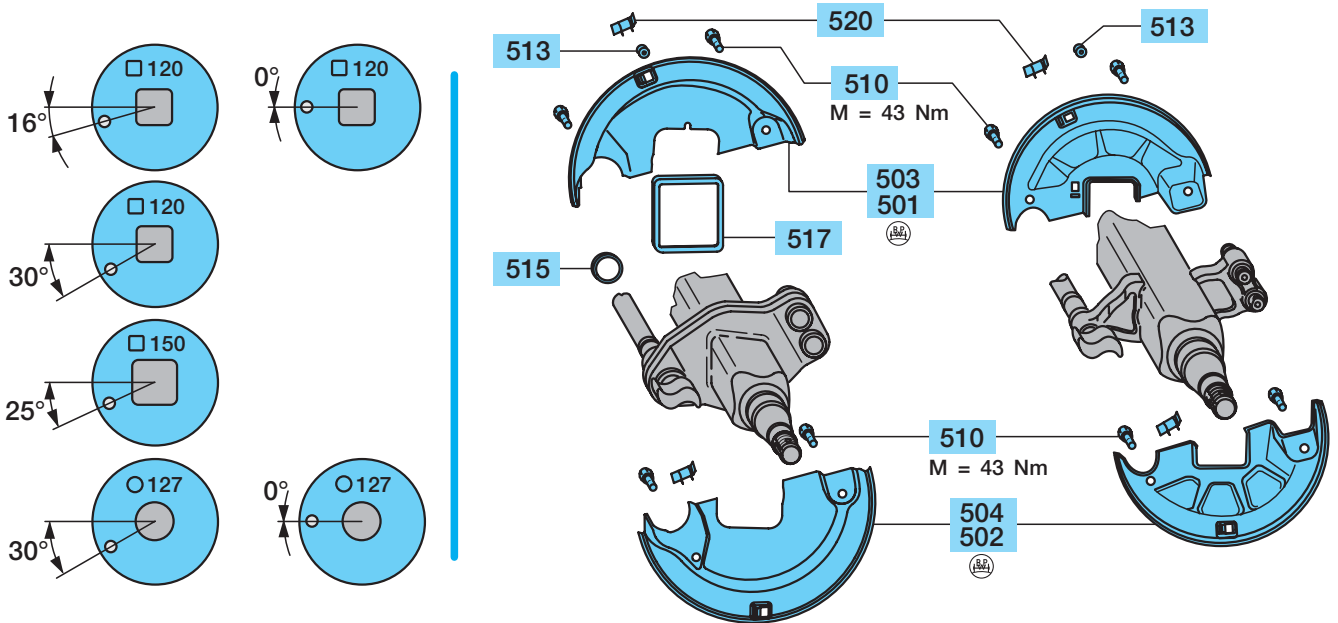

Item	Designation (Remark)	BPW Code no.				
<b>SN 42..</b>			<b>H.. / R..</b>			
500	Brake designation	item 500	item 501	item 502	item 503	item 504
-	Axle type	Set of dust covers	Dust cover	Dust cover	Dust cover	Dust cover
504	Axle beam	cpl.	left upper	left lower	right upper	right lower
	Brake position	item 501 - 520				
<b>SN 4212-2</b> ---,---,790,--- / ---,---,794,---						
H..	□ 120 30°	99.00.000.0.70	03.010.98.53.0	03.010.98.24.0	03.010.98.54.0	03.010.98.25.0
H..	□ 120 16°	99.00.000.0.87	03.010.99.38.0	03.010.99.37.0	03.010.99.40.0	03.010.99.39.0
<b>SN 4212 BPW 95</b> ---,---,741,---						
H..	□ 120 16°	-	03.010.91.32.0	03.010.91.31.0	03.010.91.34.0	03.010.91.33.0
<b>SN 4218-2</b> ---,---,710,--- / ---,---,714,---						
H..	□ 120 30°	<b>99.00.000.0.71</b>	03.010.98.45.1	03.010.98.08.0	03.010.98.46.1	03.010.98.09.0
H..	□ 120 16°	<b>99.00.000.0.88</b>	03.010.99.34.0	03.010.99.33.0	03.010.99.36.0	03.010.99.35.0
H..	□ 150 25°	99.00.000.0.80	03.010.98.91.0	03.010.98.12.0	03.010.98.92.0	03.010.98.13.0
R..	○ 127 30°	99.00.000.0.72	03.010.98.69.0	03.010.98.06.0	03.010.98.70.0	03.010.98.05.0
<b>SN 4218 BPW 95</b> ---,---,743,---						
H..	□ 120 30°	<b>99.00.000.1.07</b>	03.010.99.93.0	03.010.99.94.0	03.010.99.91.0	03.010.99.92.0
H..	□ 120 16°	<b>99.00.000.0.93</b>	03.010.99.59.0	03.010.99.60.0	03.010.99.57.0	03.010.99.58.0
H..	□ 150 25°	99.00.000.0.95	03.010.99.67.0	03.010.99.68.0	03.010.99.65.0	03.010.99.66.0
R..	○ 127 30°	99.00.000.0.94	03.010.99.75.0	03.010.99.73.0	03.010.99.73.0	03.010.99.75.0
<b>SN 4220-2</b> ---,---,718,--- / ---,---,723,---						
H..	□ 120 30°	99.00.000.0.75	03.010.98.51.1	03.010.98.16.0	03.010.98.52.1	03.010.98.17.0
H..	□ 120 16°	99.00.000.0.89	03.010.99.42.0	03.010.99.41.0	03.010.99.44.0	03.010.99.43.0
H..	□ 150 25°	99.00.000.0.73	03.010.98.47.1	03.010.97.94.0	03.010.98.48.1	03.010.97.95.0
R..	○ 127 30°	99.00.000.0.85	03.010.98.65.0	03.010.97.98.0	03.010.98.66.0	03.010.97.97.0
<b>SN 4220 BPW 95</b> ---,---,744,---						
H..	□ 120 30°	99.00.000.0.97	03.010.99.55.0	03.010.99.56.0	03.010.99.53.0	03.010.99.54.0
H..	□ 120 16°	-	03.010.91.37.0	03.010.91.38.0	03.010.91.35.0	03.010.91.36.0
H..	□ 150 25°	<b>99.00.000.0.98</b>	03.010.99.63.0	03.010.99.64.0	03.010.99.61.0	03.010.99.62.0
R..	○ 127 30°	-	03.010.99.71.0	03.010.99.69.0	03.010.99.69.0	03.010.99.71.0
<b>SN 4222-2</b> ---,---,739,---						
H..	□ 150 25°	99.00.000.0.76	03.010.98.49.1	03.010.98.20.0	03.010.98.50.1	03.010.98.21.0
<b>SN 4222 BPW 95</b> ---,---,745,---						
H..	□ 150 25°	-	05.010.91.21.0	05.010.91.22.0	05.010.91.24.0	05.010.91.23.0



## Dust covers 4.5

Item	Designation (Remark)	BPW Code no.	Dimension			
<b>SN 36..</b>						<b>KH.. / KR..</b>
500 - 504	Brake designation Axle type Axle beam Brake position	item 500 Set of dust covers cpl. item 501 - 520	item 501 Dust cover left upper	item 502 Dust cover left lower	item 503 Dust cover right upper	item 504 Dust cover right lower
<b>SN 3616 ---.542.---</b>						
	KR..     ○ 127	99.00.000.0.81	03.010.96.53.0	03.010.96.50.0	03.010.96.52.0	03.010.96.51.0
	KM..     ■ 120	99.00.000.1.08	03.010.91.10.0	03.010.91.09.0	03.010.91.12.0	03.010.91.11.0
<b>SN 3616 BPW 95 ---.551.---</b>						
	KH..     □ 120	99.00.000.1.06	03.010.99.79.0	03.010.99.80.0	03.010.99.77.0	03.010.99.78.0
<b>SN 3620 ---.546.---</b>						
	KR..     ○ 127	99.00.000.0.81	03.010.96.53.0	03.010.96.50.0	03.010.96.52.0	03.010.96.51.0
	KH.. / KM..   □ 120	99.00.000.0.83	03.010.96.67.0	03.010.96.68.0	03.010.96.70.0	03.010.96.69.0
<b>SN 3620 BPW 95 ---.552.---</b>						
	KR..     ○ 127	99.00.000.0.81	03.010.96.53.0	03.010.96.50.0	03.010.96.52.0	03.010.96.51.0
	KH.. / KM..   □ 120	99.00.000.1.06	03.010.99.79.0	03.010.99.80.0	03.010.99.77.0	03.010.99.78.0

<b>SN 30..</b>						<b>NH.. / NR..</b>
500 - 504	Brake designation Axle type Axle beam Brake position	item 500 Set of dust covers cpl. item 501 - 520	item 501 Dust cover left upper	item 502 Dust cover left lower	item 503 Dust cover right upper	item 504 Dust cover right lower
<b>SN 3015-1 ---.582.---</b>						
	NR..     ○ 127 0°	99.00.000.1.00	03.010.96.48.0	03.010.96.40.0	03.010.96.49.0	03.010.96.41.0
<b>SN 3015 ---.592.---</b>						
	NR..     ○ 127 0°	99.00.000.1.01	03.010.96.84.0	03.010.96.83.0	03.010.96.85.0	03.010.96.86.0
	NH..     □ 120 0°	99.00.000.1.02	03.010.91.08.0	03.010.91.07.0	03.010.91.06.0	03.010.91.05.0
<b>SN 3015 BPW 95 ---.501.---</b>						
	NH..     □ 120 0°	-	03.010.99.83.0	03.010.99.84.0	03.010.99.81.0	03.010.99.82.0
<b>SN 3020-1 ---.586.---</b>						
	NR..     ○ 127 0°	99.00.000.1.03	03.010.96.33.0	03.010.96.20.0	03.010.96.32.0	03.010.96.21.0
<b>SN 3020 ---.596.---</b>						
	NR..     ○ 127 0°	99.00.000.0.84	03.010.96.80.0	03.010.96.79.0	03.010.96.82.0	03.010.96.81.0
	NH..     □ 120 0°	99.00.000.1.05	03.010.91.02.0	03.010.91.01.0	03.010.91.03.0	03.010.91.04.0
<b>SN 3020 BPW 95 ---.502.---</b>						
	NH..     □ 120 0°	99.00.000.1.09	03.010.99.87.0	03.010.99.88.0	03.010.99.85.0	03.010.99.86.0

510	Locking screw	02.5071.22.00	M 10 x 18			
	Locking screw	02.5070.83.00	M 10 x 20			
513	Plug (without ABS)	02.3704.33.00	Ø 10.7			
	Seal (with ABS)	02.5681.78.00	Ø 6 / 10 / 13			
515	Seal <sup>1)</sup>	03.120.23.06.0	Ø 52 / 68 / 8			
517	Seal <sup>1)</sup>	05.121.30.06.0	L = 340, □ 8			
	□ 120/○ 127					
	□ 150	05.121.30.07.0	L = 450, □ 8			
520	Plug	03.379.00.23.0				
<sup>1)</sup> not necessary with brake position 16°						

4.6 Brake cylinder

Diaphragm cylinders

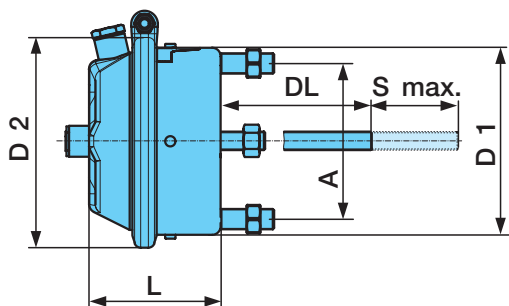

Brake cylinder set incl. yoke with round hole  
BPW Code no.: 05.444.xx.xx.1

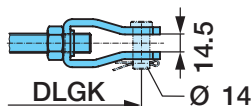

Pre-assembled spring-type cylinder, ready for installation

Brake cylinder set incl. yoke with elongated hole  
BPW Code no.: 05.444.xx.xx.2

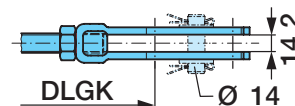

Only for diaphragm cylinder version

Brake cylinder size	BPW Code no.	Air connection thread	L (mm)	D 1 (mm)	D 2 (mm)	A (mm) Connection dimension	DL (mm) without yoke	DLGK (mm) with yoke
9"	02.0327.98.00	M 12 x 1.5	108	112	135	76.2	186	227
12"	02.0327.99.00	M 12 x 1.5	114	123	144	76.2	186	227
16"	05.444.13.01.0	M 16 x 1.5	120	145	165	120.7	185	227
20"	05.444.14.01.0	M 16 x 1.5	120	151	180	120.7	185	227
	05.444.14.02.0 <sup>3)</sup>	5/8"-18 UNF						
24"	05.444.15.01.0	M 16 x 1.5	120	162	190	120.7	185	227
	05.444.15.02.0	5/8"-18 UNF						
	05.444.15.04.0 <sup>1)</sup>	M 16 x 1.5					142	184
	05.444.15.10.0	M 16 x 1.5						
	05.444.15.11.0	M 16 x 1.5						
30"	05.444.16.01.0	M 16 x 1.5	125	178	215	120.7	185	227
	05.444.16.02.0 <sup>3)</sup>	5/8"-18 UNF						
	05.444.16.04.0 <sup>1)</sup>	M 16 x 1.5					142	184
	05.444.16.05.0 <sup>2)</sup>	5/8"-18 UNF						
	05.444.16.10.0	M 16 x 1.5						
	05.444.16.11.0	M 16 x 1.5						
36"	05.444.17.01.0	M 16 x 1.5	135	201	225	120.7	185	227
	05.444.17.02.0 <sup>3)</sup>	5/8"-18 UNF						

<sup>1)</sup> Air connection turned on 90°

<sup>2)</sup> with air connection 1/2" NPTF

<sup>3)</sup> with air connection 3/8" NPTF

## Diaphragm-diagram (M-M) cylinders

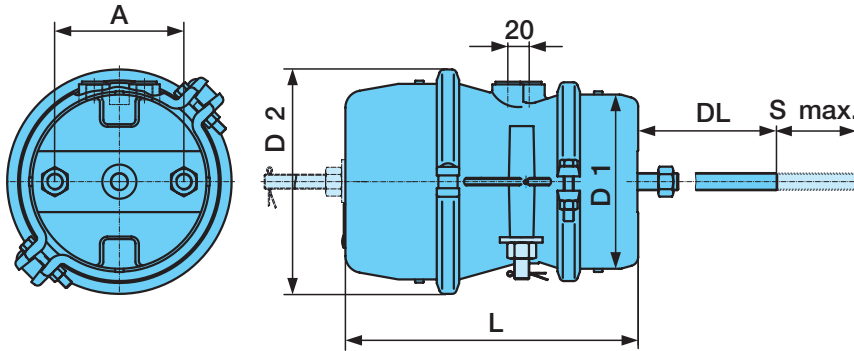

Brake cylinder set incl.  
yoke with round hole  
BPW Code no.: 05.444.xx.xx.1

Pre-assembled spring-type  
cylinder, ready for installation

Brake cylinder size	BPW Code no.	Air connection thread	L (mm)	D 1 (mm)	D 2 (mm)	A (mm) Connection dimension	DL (mm) without yoke	DLGK (mm) with yoke
16/24"	05.444.18.01.0	M 16 x 1.5	232	145	185	120.7	185	227
20/30"	05.444.19.01.0	M 16 x 1.5	274	163	211	120.7	185	227
	05.444.19.02.0 <sup>3)</sup>	5/8"-18 UNF						
24/30"	05.444.20.01.0	M 16 x 1.5	274	163	211	120.7	185	227
	05.444.20.02.0 <sup>3)</sup>	5/8"-18 UNF						
	05.444.20.04.0 <sup>1)</sup>	M 16 x 1.5					142	184
	05.444.20.10.0	M 16 x 1.5						
	05.444.20.11.0	M 16 x 1.5						
30/30"	05.444.21.01.0	M 16 x 1.5	274	185	211	120.7	185	227
	05.444.21.02.0 <sup>3)</sup>	5/8"-18 UNF						
	05.444.21.04.0 <sup>1)</sup>	M 16 x 1.5					142	184
	05.444.21.05.0 <sup>2)</sup>	5/8"-18 UNF						
	05.444.21.10.0	M 16 x 1.5						
	05.444.21.11.0	M 16 x 1.5						

<sup>1)</sup> Air connection turned on 90°

<sup>2)</sup> with air connection 1/2" NPTF

<sup>3)</sup> with air connection 3/8" NPTF

5 Hub bearings, hub seals

H  
K  
N

**General**

**BPW hub bearings**

**Conventional hub bearing system**

Until introduction of the ECO hub system, BPW supplied trailer axles with conventional hub bearings.

In this hub bearing, the 2 sealing rings are mounted on the stepped thrust washer (oil seals are used in the N.. axle series).

Use a pulling device to pull off the complete hub unit. The tapered roller bearing inner race of the rear bearing as well as the thrust washer with seal then remain on the axle stub and must be pulled off separately, if necessary.

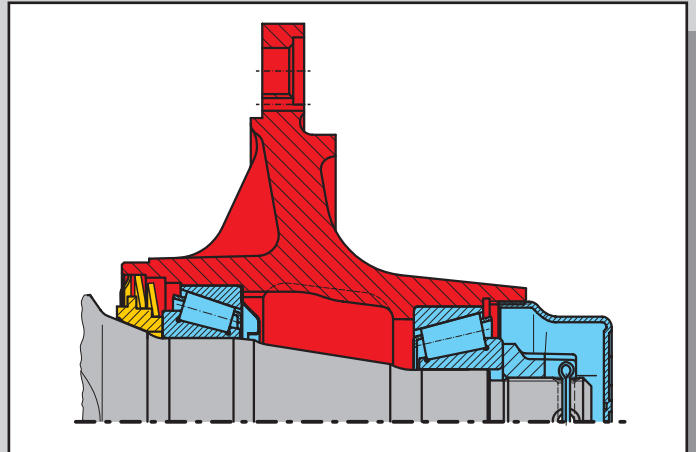

**ECO hub bearing system**

Dismantling the patented BPW ECO hub system (European patent 0 407 719 B1) couldn't be simpler:

In only a few operations, the wheel (complete with the hub, roller bearings and brake drum) is removed using the central screw connection – just like wheel changes in motor racing.

The stepped bearing means there is no need to use a puller or other special tools.

The roller bearings remain in the hub where they are well protected against dirt and moisture.

Installation is also quick and easy: Box spanners are all that are required for the hub cap and axle nuts.

The wheel can remain fitted to the hub during removal and installation.

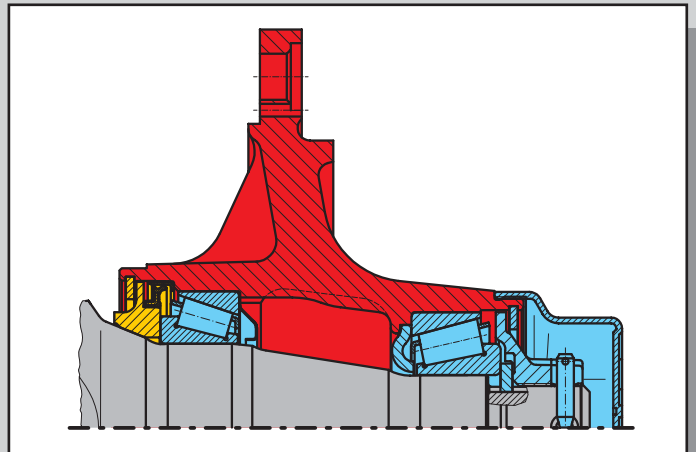

**ECOPlus hub bearing system**

If you expect high mileages, rapid servicing and low maintenance costs from your axles, then only ECOPlus will do.

Ground-breaking ECOPlus bearing technology was developed on the basis of the special BPW ECO hub system.

The maintenance-free hub has an integrated multi-seal system for protecting the tapered roller bearings against dust and dirt.

A central screw connection with integrated torque limiting function ensures the bearing preload is always optimum.

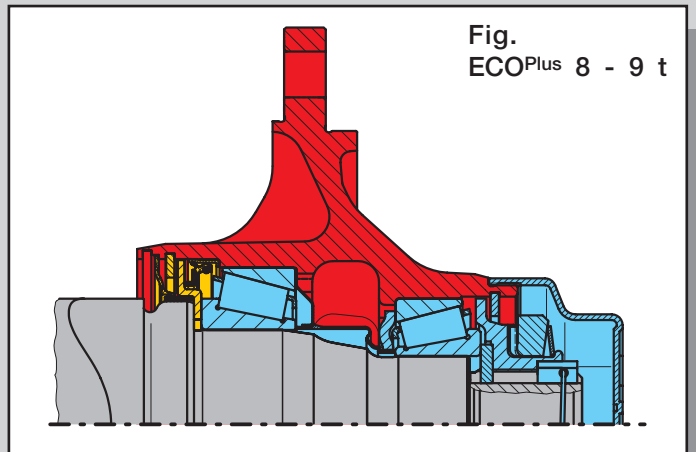

**Uniform axle stubs for all BPW trailer axles**

As of January 1995 BPW axle beams and steering pivots will be converted to ECO axle stubs.

These differ from the conventional axle stubs by a keyway in the thread area.

A new axle nut and in addition a washer is used to fit the conventional bearing to ECO axle stubs.

Where spare axle beams and steering pivot assemblies are supplied, these are fitted throughout with these new axle nuts and washers.

If the ECO hub system is fitted, these parts are dispensed with.

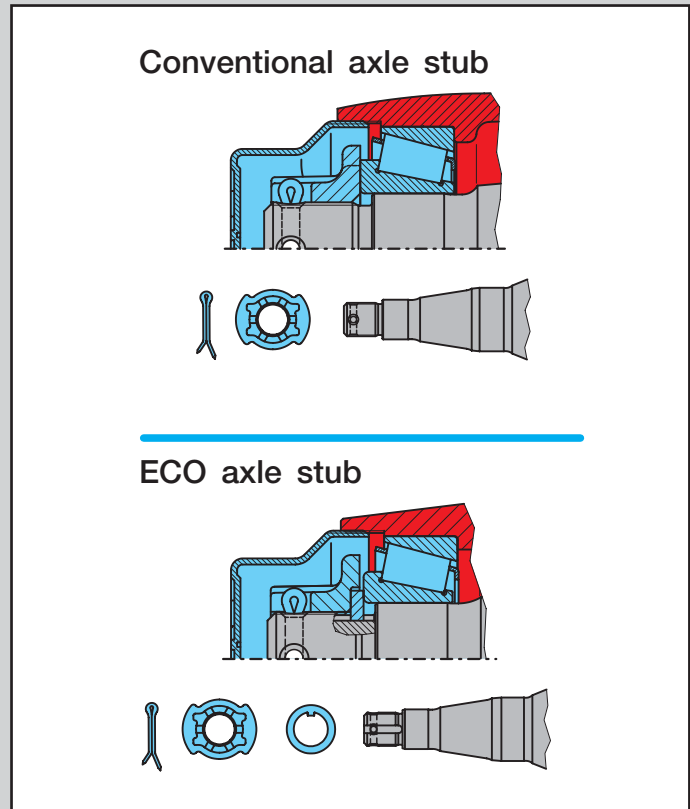

**New seals for ECOPlus hub bearing system**

Starting in October 2004, BPW will be introducing the new ECOSeal hub bearing sealing system.

With a larger dirt seal and new two stage dust seal, the proven concept of the ECOPlus seal has clearly been further improved in a number of areas.

For example, the primary sealing lip is no longer fitted directly against the hub bearing, but instead fits against a special thrust race integrated into the seal assembly.

This new design enables the circumferential velocity of the seal to be significantly reduced, and with that, the amount of wear. In addition, the wheel bearing is provided with even better protection against dirt penetration by means of the covering dust and dirt sealing lips.

The race remains in the hub when changing over to the new seal.

New ECOPlus bearings are supplied without a race.

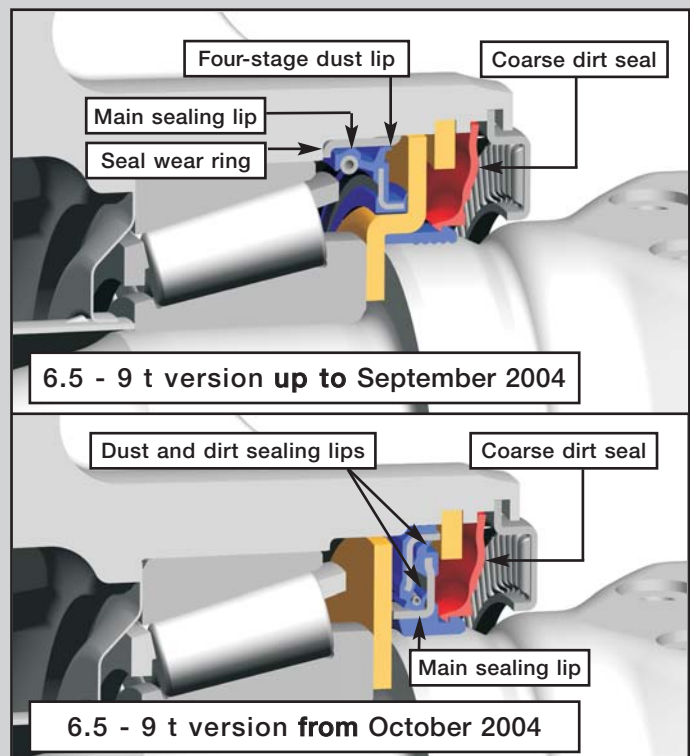

5.1 Hub bearings, hub seals

Conventional hub bearing system

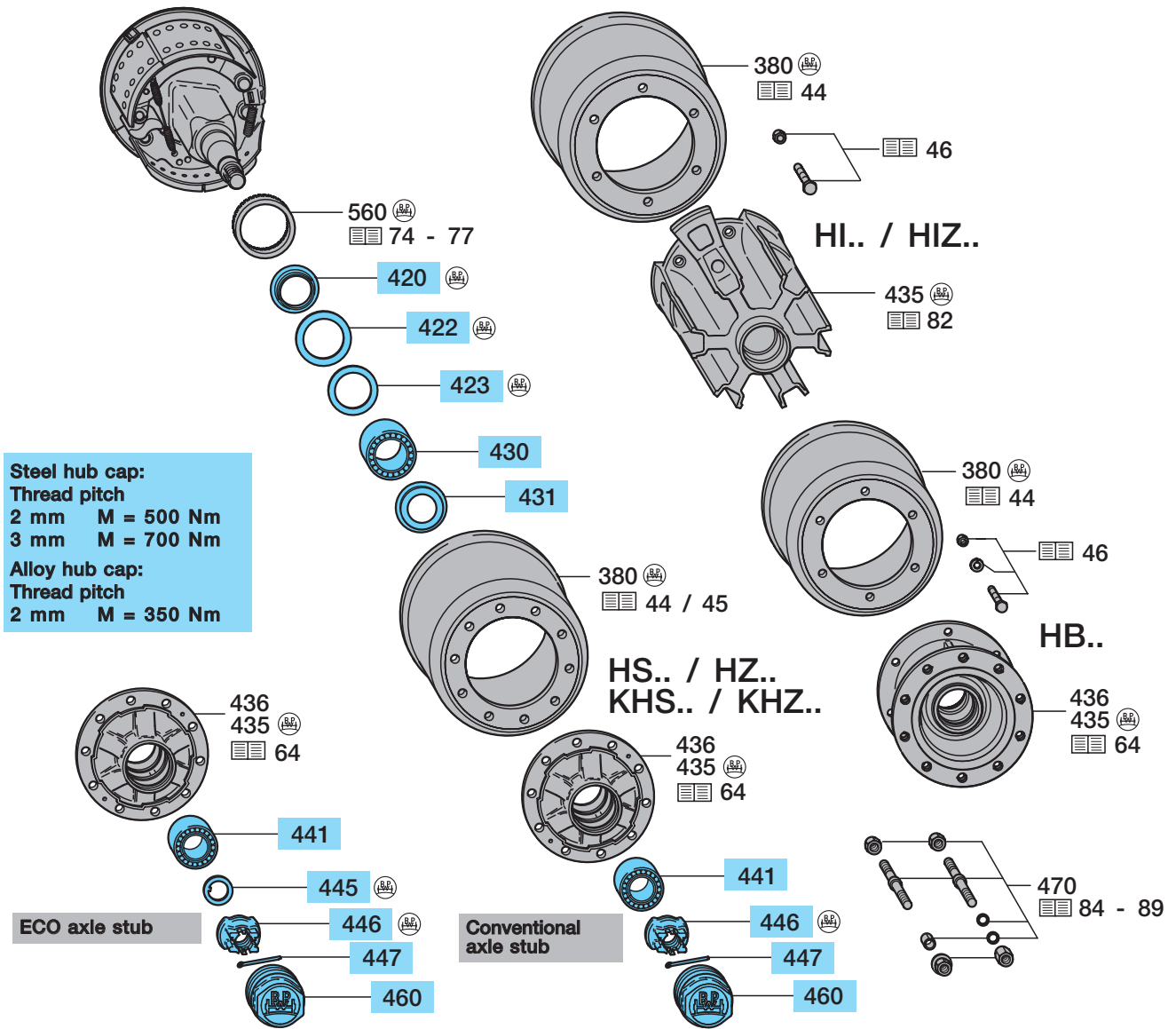

Grease filling, grease quantity and bearing adjustment see page 68

Hub caps with integrated Hubodometer see page 90 / 91

**Uniform axle stubs for all BPW trailer axles**

As of January 1995 BPW axle beams and steering pivots will be converted to ECO axle stubs.

These differ from the conventional axle stubs by a keyway in the thread area.

A new axle nut (item 446) and in addition a washer (item 445) is used to fit the conventional bearing to ECO axle stubs.

Where spare axle beams and steering pivot assemblies are supplied, these are fitted throughout with these new axle nuts and washers.

If the ECO hub system is fitted, these parts are dispensed with.

Conventional axle stub

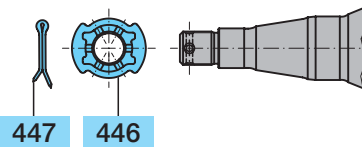
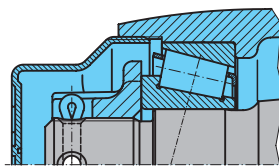

ECO axle stub

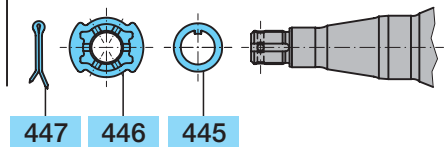
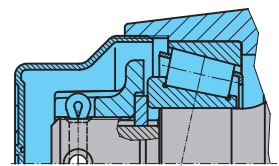

### Conventional hub bearing system

Item	Designation (Remark)	BPW Code no.	Dimension		
		<b>KRBM 6408</b> --.65.---,---		<b>H.. / R..; KH.. / KR..</b> <b>6.5 - 9 t</b> --.06. / 08. / 09.---,---	<b>H.. / R..; KH.. / KR..</b> <b>10 - 12 t</b> --.10.---,---
380	Brake drum	see page 45		see page 44 / 45	see page 44 / 45
418	Repair kit roller bearing <b>with</b> thrust washer and hub cap (item 420-431, 441, 447, 460)	-		<b>09.801.02.17.0</b> for 1 axle side	<b>09.801.02.18.0</b> for 1 axle side
	Repair kit roller bearing <b>without</b> thrust washer and hub cap (item 422-431, 441, 447)	-		09.801.02.24.0 for 1 axle side	09.801.02.98.0 for 1 axle side
420	Thrust washer	05.370.06.11.0		05.370.06.48.0	05.370.07.43.0
422	Ring (Nylon)	03.310.97.14.0	Ø 105/141x2.5	03.310.97.31.0 Ø 110/141x2.5	03.310.98.21.0 Ø 128/165x2.5
423	Ring (Nylon)	03.310.97.13.0	Ø 100/134x2.5	03.310.97.32.0 Ø 104/136x2.5	03.310.97.30.0 Ø 120/157x2.5
430	Roller bearing e.g.	<b>02.6410.29.00</b> 02.6407.75.00	33215	<b>02.6410.24.00</b> 02.6408.80.00	<b>02.6410.23.00</b> 02.6408.90.00
				33116	33118
431	Dust cover	03.010.04.09.0	Ø 79/129x8.5	03.010.04.15.0 Ø 84/129x8.5	03.010.05.22.0 Ø 94/149x8.5
435	Hub	see page 64		see page 64	see page 64
441	Roller bearing e.g.	<b>02.6410.25.00</b> 02.6406.50.00	32310	<b>02.6410.25.00</b> 02.6406.50.00	<b>02.6410.22.00</b> 02.6407.65.00
				32310	33213
<b>Conventional axle stub (see page 54)</b>					
446	Castle nut	03.262.16.10.0	M 42x2/SW65/ H 36	03.262.16.08.0 M 42x2/SW65	03.262.17.12.0 M 52x2/SW80
447	Split pin	02.6201.82.01	8 x 50 / 94	02.6201.82.01 8 x 50 / 94	02.6201.84.01 8 x 63 / 94
<b>ECO axle stub (see page 54)</b>					
445	Washer	03.320.73.13.0	Ø 43/61x5.8	03.320.73.13.0 Ø 43/61x5.8	03.320.64.01.0 Ø 53/76x5.8
446	Castle nut	03.262.16.15.0	M 42x2/SW65	03.262.16.15.0 M 42x2/SW65	03.262.17.18.0 M 52x2/SW80
447	Split pin	02.6201.82.01	8 x 50 / 94	02.6201.82.01 8 x 50 / 94	02.6201.84.01 8 x 63 / 94
460	Hub cap (standard) (chrome)	03.212.23.32.0 -	M 115 x 2 / SW 95 - oct., alloy	03.212.23.09.0 M 115 x 2 / SW 95	03.212.24.07.0 M 125 x 2 / SW 110

H

K

5.1 Hub bearings, hub seals

Conventional hub bearing system

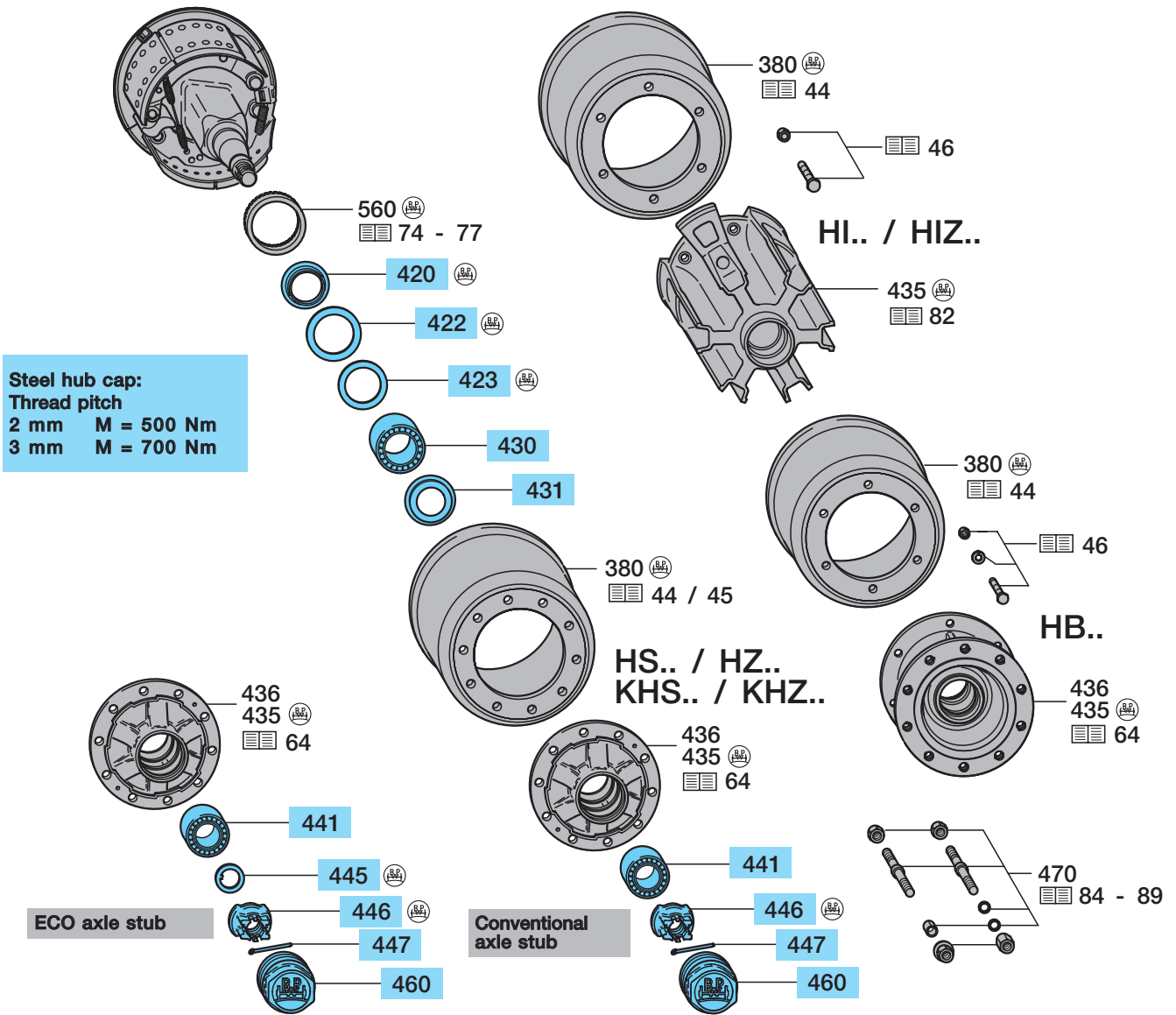

Grease filling, grease quantity and bearing adjustment see page 68

Hub caps with integrated Hubodometer see page 90 / 91

**Uniform axle stubs for all BPW trailer axles**

As of January 1995 BPW axle beams and steering pivots will be converted to ECO axle stubs.

These differ from the conventional axle stubs by a keyway in the thread area.

A new axle nut (item 446) and in addition a washer (item 445) is used to fit the conventional bearing to ECO axle stubs.

Where spare axle beams and steering pivot assemblies are supplied, these are fitted throughout with these new axle nuts and washers.

If the ECO hub system is fitted, these parts are dispensed with.

Conventional axle stub

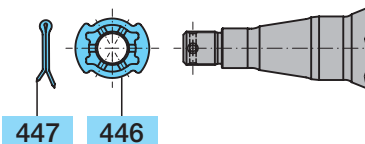
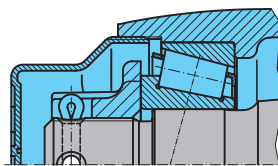

ECO axle stub

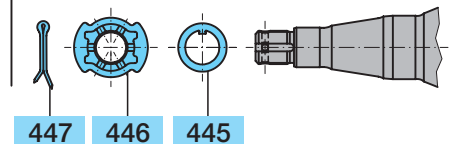
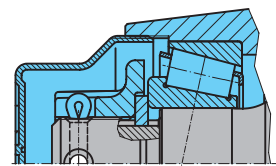



**Conventional hub bearing system**

Item	Designation (Remark)	BPW Code no.	Dimension
		<b>H. / K.. 13 - 14 t (14000-1) --.14.---.---</b>	<b>H.. 16 - 18 t --.16.---.---</b>
380	Brake drum	see page 44 / 45	see page 44
420	Thrust washer	05.370.07.20.0	05.370.07.04.0
422	Ring (Nylon)	03.310.38.21.0	Ø 130/186x4
423	Ring (Nylon)	03.310.38.20.0	Ø 124/181x4
430	Roller bearing e.g.	<b>02.6410.28.00</b> 02.6405.95.00	32219
431	Dust cover	03.010.05.21.0	Ø 99/169x8.5
435	Hub	see page 64	see page 64
441	Roller bearing e.g.	<b>02.6410.29.00</b> 02.6407.75.00	33215
		<b>02.6410.26.00</b> 02.6405.11.00	32222
		03.010.06.12.0	Ø 114/199x8.5
		03.262.17.11.0	M 60x2/SW85
		02.6202.03.01	10 x 71 / 94
		<b>02.6410.27.00</b> 02.6406.70.00	32314
		<b>Conventional axle stub (see page 56)</b>	
446	Castle nut	03.262.17.11.0	M 60x2/SW85
447	Split pin	02.6202.03.01	10 x 71 / 94
		<b>ECO axle stub (see page 56)</b>	
445	Ring	03.310.75.12.0	Ø 61/88x5.8
446	Castle nut	03.262.17.19.0	M 60x2/SW85
447	Split pin	02.6202.03.01	10 x 71 / 94
460	Hub cap (outer thread)	03.212.25.02.0	M 135 x 3 / SW 120
	Hub cap (inner thread)	03.212.26.20.0	M 150 x 2 / SW 120

Only 14 t hubs and hub caps with M 135 x 3 hub/hub cap thread are replaced by hubs and hub caps with M 150 x 2 thread. Note the modified components.

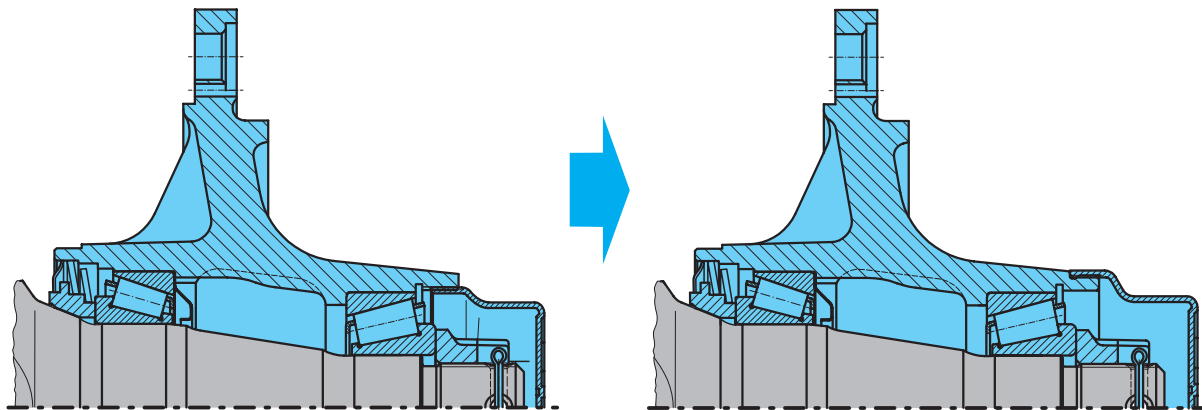

until 11/2004  
Hub with inner thread M 135 x 3  
Hub cap with outer thread M 135 x 3

up to 11/2004  
Hub with outer thread M 150 x 2  
Hub cap with inner thread M 150 x 2

5.1 Hub bearings, hub seals

Conventional hub bearing system

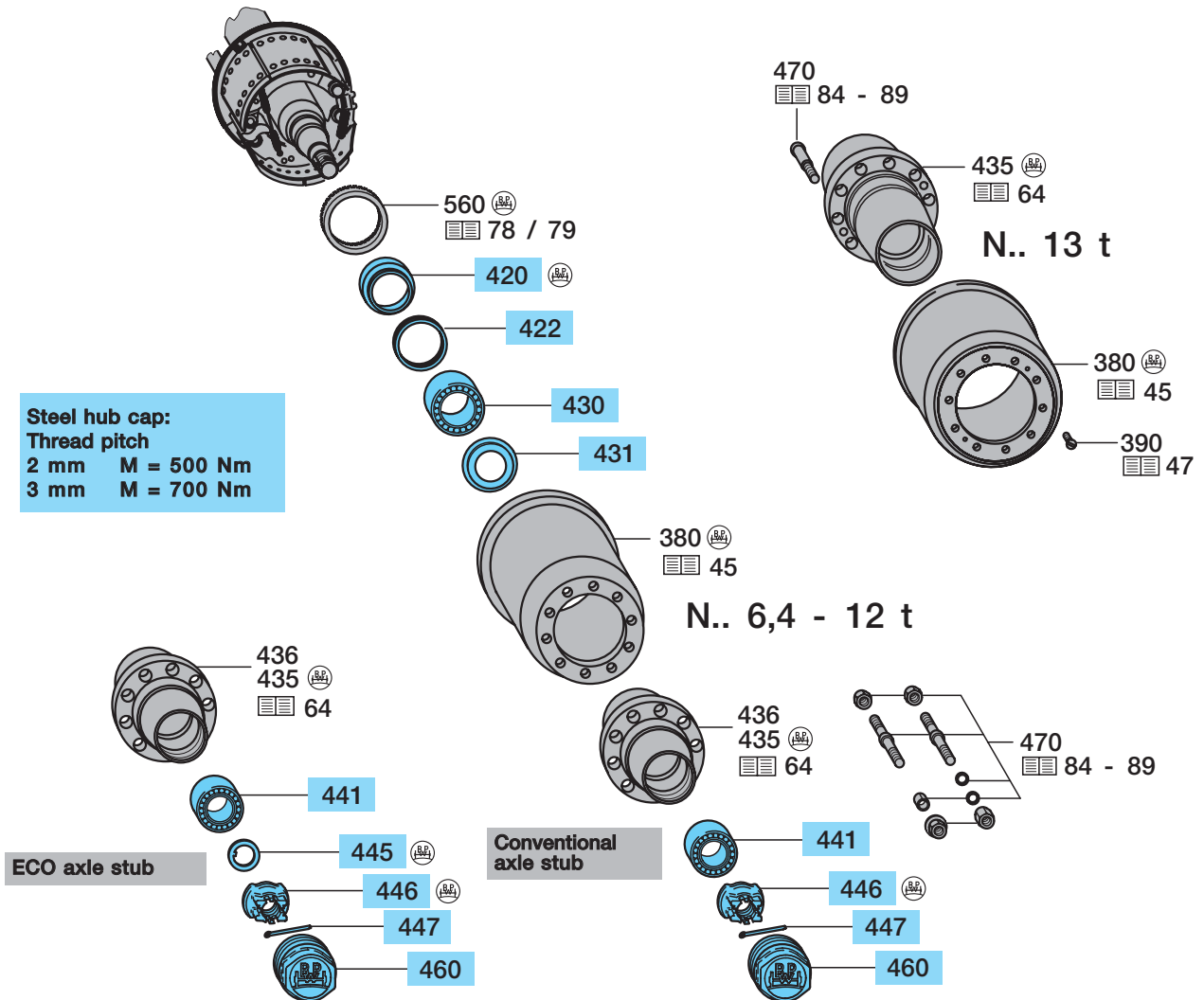

Grease filling, grease quantity and bearing adjustment see page 68

Hub caps with integrated Hubodimeter see page 90 / 91

**Uniform axle stubs for all BPW trailer axles**

As of January 1995 BPW axle beams and steering pivots will be converted to ECO axle stubs.

These differ from the conventional axle stubs by a keyway in the thread area. A new axle nut (item 446) and in addition a washer (item 445) is used to fit the conventional bearing to ECO axle stubs.

Where spare axle beams and steering pivot assemblies are supplied, these are fitted throughout with these new axle nuts and washers.

If the ECO hub system is fitted, these parts are dispensed with.

Conventional axle stub

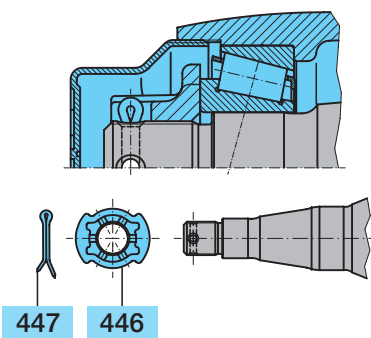

ECO axle stub

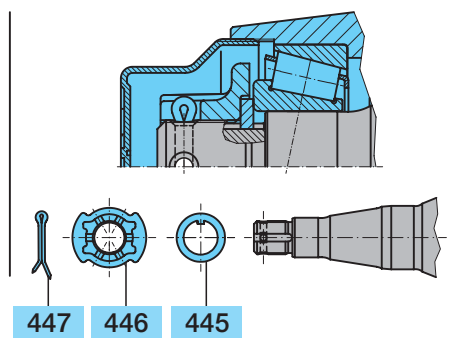

### Conventional hub bearing system

Item	Designation (Remark)	BPW Code no.	Dimension
		<b>NH.. / NR..</b> <b>6.4 - 9 t</b> <b>--.06 / 08 / 09.----,---</b>	<b>NH.. / NR..</b> <b>10 - 12 t</b> <b>--.10.----,---</b>
		<b>NR..</b> <b>13 t</b> <b>--.14.----,---</b>	
380	Brake drum	see page 45	see page 45
418	Repair kit roller bearing <b>with</b> thrust washer and hub cap (item 420 - 431, 441, 447, 460)	<b>09.801.02.19.0</b> for 1 axle side	<b>09.801.02.20.0</b> for 1 axle side
420	Thrust washer	03.370.07.45.0    Ø 86/125x22	03.370.07.44.0    Ø 96/145x22
422	Lip seal	02.5664.26.57    Ø 125/143x13	02.5664.46.57    Ø 145/167x13
430	Roller bearing            e.g.	<b>02.6410.24.00</b> 02.6408.80.00    33116	<b>02.6410.23.00</b> 02.6408.90.00    33118
431	Dust cover	03.010.04.15.0    Ø 84/129x8.5	03.010.05.22.0    Ø 94/149x8.5
435	Hub	see page 60	see page 60
441	Roller bearing            e.g.	<b>02.6410.25.00</b> 02.6406.50.00    32310	<b>02.6410.22.00</b> 02.6407.65.00    33213
<b>Conventional axle stub (see page 58)</b>			
446	Castle nut	03.262.16.08.0    M 42x2/SW65	03.262.17.12.0    M 52x2/SW80
447	Split pin	02.6201.82.01    8 x 50 / 94	02.6201.84.01    8 x 63 / 94
<b>ECO axle stub (see page 58)</b>			
445	Washer Ring	03.320.73.13.0    Ø 43/61x5.8 -	03.320.64.01.0    Ø 53/76x5.8 -
446	Castle nut	03.262.16.15.0    M 42x2/SW65	03.262.17.18.0    M 52x2/SW80
447	Split pin	02.6201.82.01    8 x 50 / 94	02.6201.84.01    8 x 63 / 94
460	Hub cap            (normal) (chrome)	03.212.23.09.0    M 115 x 2 / 03.212.23.21.0    SW 95	03.212.24.07.0    M 125 x 2 / 03.212.24.23.0    SW 110
			03.212.25.02.0    M 135 x 3 / -                        SW 120

N

5.2 Hub bearings, hub seals

ECO / ECO MAXX hub system

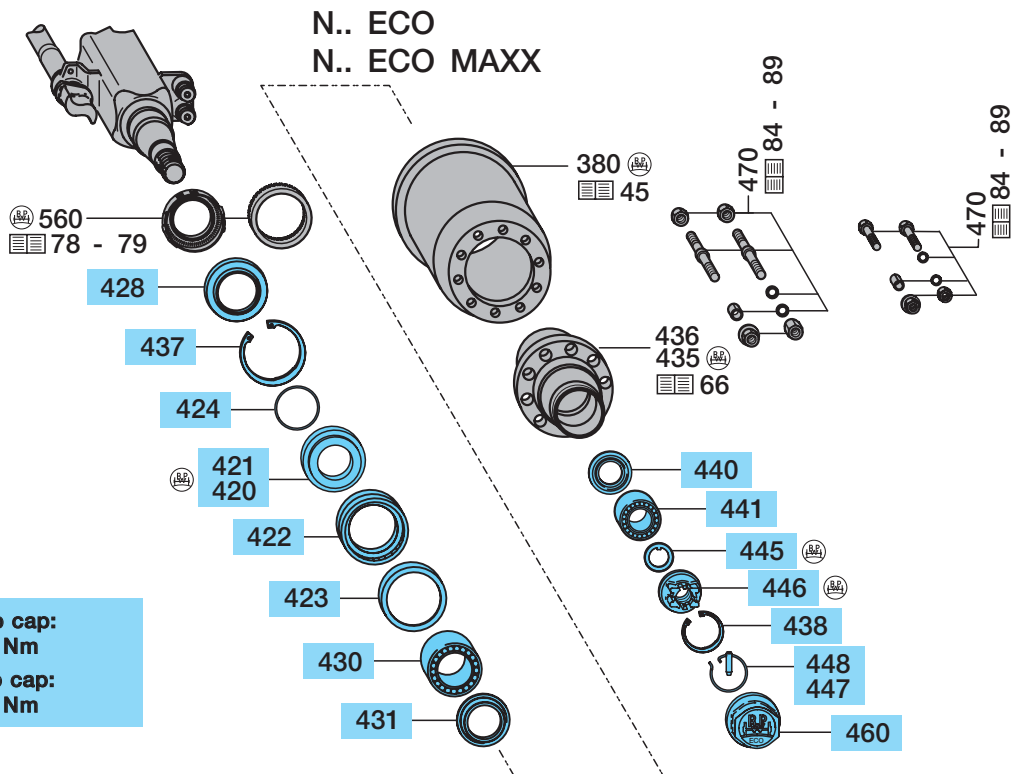
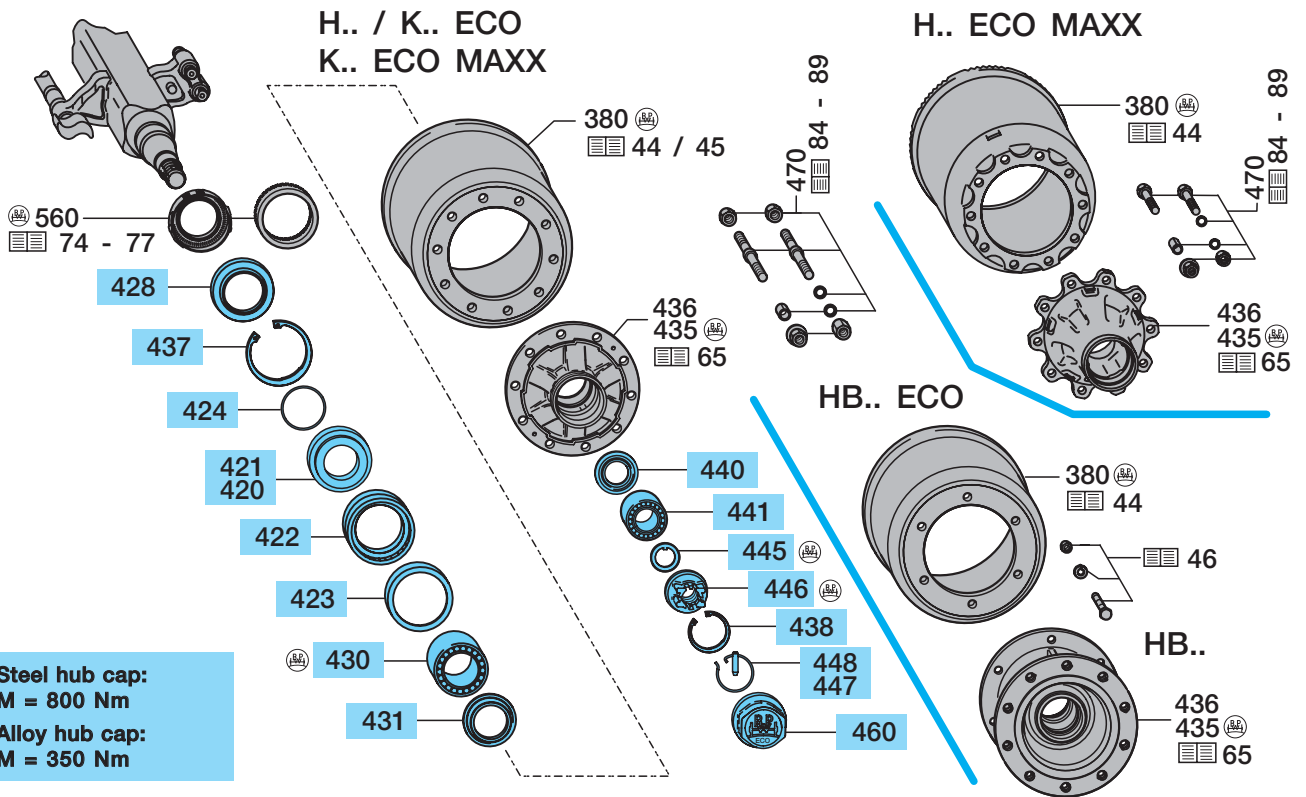

Grease filling, grease quantity and bearing adjustment see page 69

Hub caps with integrated Hubodometer see page 90 / 91



## Hub bearings, hub seals 5.2

ECO / ECO MAXX hub system							
Item	Designation (Remark)	BPW Code no.	Dimension				
		H.. / R.. / KH.. / KR.. / NH.. / NR.. ECO / ECO MAXX 6.5 - 9 t --.36 / 38.---,---	H.. / R.. / KH.. / KR.. / NH.. / NR.. ECO / ECO MAXX 10 - 12 t --.40.---,---	H.. ECO 13 - 14 t --.44.---,---			
380	Brake drum	see page 44 / 45	see page 44 / 45	see page 44			
418	Repair kit roller bearing <b>with</b> axle nut and hub cap (item 420, 423, 428 - 431, 437 - 460)	<b>09.801.02.33.0</b> for 1 axle side	<b>09.801.02.34.0</b> for 1 axle side	-			
	Repair kit roller bearing <b>without</b> axle nut and hub cap (item 420, 423, 430, 431, 441 - 445)	09.801.02.72.0 for 1 axle side	09.801.06.89.0 for 1 axle side	-			
420	Thrust washer cpl. (item 421, 422, 424)	05.370.07.67.0	05.370.07.65.0	05.370.08.19.0			
421	Thrust washer	03.370.07.60.0	Ø 86 / 115 / 139 x 22	03.370.07.62.0	Ø 96 / 135 / 159 x 22	03.370.08.18.0	Ø 97 / 177 / 179 x 34
422	Lip seal	02.5664.57.00	137-115-10.5	02.5664.58.00	Ø 157-135-8	02.5664.59.00	177-155-8
423	Ring	02.5683.62.00	Ø 131/140x12	02.5683.63.00	Ø 151/160x12	02.5683.69.00	Ø 171/179x12
424	'O'-Ring	02.5677.90.40	Ø 90 x 3	02.5678.00.00	Ø 100 x 3	-	
428	Dirt seal	02.5681.98.00	Ø 103/147x15	03.120.48.13.0	Ø 133/168x15	-	
430	Roller bearing e.g.	<b>02.6410.24.00</b> 02.6408.80.00	33116	<b>02.6410.23.00</b> 02.6408.90.00	33118	<b>02.6410.28.00</b> 02.6405.95.00	32219
431	Dust cover	03.010.93.33.0	Ø 84/129x8.5	03.010.93.34.0	Ø 94/149x8.5	03.010.23.03.0	Ø 103/169x8.5
435	Hub	see page 65 / 66	see page 65 / 66	see page 65			
437	Circlip	02.5606.40.90	140 x 4 / 472	02.5606.60.90	160x4/472	02.5606.68.90	180x4/472
438	Circlip	02.5606.12.90	112 x 4 / 472	02.5606.22.90	122x4/472	02.5606.32.90	132x4/472
440	Thrust washer	03.370.25.16.0	Ø 53 / 98 x 8	03.370.26.24.0	Ø 71/108x9.5	03.370.26.23.0	Ø 77/120x10
441	Roller bearing e.g.	<b>02.6410.25.00</b> 02.6406.50.00	32310	<b>02.6410.22.00</b> 02.6407.65.00	33213	<b>02.6410.29.00</b> 02.6407.75.00	33215
445	Washer Ring	03.320.73.13.0 -	Ø 43/61x5.8	03.320.64.01.0 -	Ø 53/76x5.8	- 03.310.75.12.0	Ø 61/88x5.8
446	Axle nut	03.266.46.02.0	M 42x2/ SW65/Ø 110	03.266.47.03.0	M 52 x 2 / SW80/Ø 120	03.262.17.17.0	M 60 x 2 / SW85/Ø 130
447	Bolt	03.084.71.17.0	Ø 8 x 45	03.084.71.17.0	Ø 8 x 45	03.084.72.63.0	Ø 10 x 45
448	Locking ring	03.188.03.06.0	Ø 54 x 2	03.188.04.08.0	Ø 66 x 2	03.188.04.09.0	Ø 76 x 2
460	Hub cap (normal) (chrome)	03.212.24.25.0 03.212.24.26.0	M 125 x 2 / SW 110	03.212.25.08.0* 03.212.25.23.0*	M 135 x 2 / SW 110	03.212.26.14.0	M 150 x 2 / SW 120
	(Alloy, for Alloy hub)	03.212.25.27.0	M 135 x 2 / SW 110	-	-	-	-

\* Modified cap thread from 09/00  
M 135 x 2 was changed to M 136 x 2.5  
Note thread size stamped on the cap!

5.3 Hub bearings, hub seals

ECOPlus hub system

ECOPlus 8 - 9 t

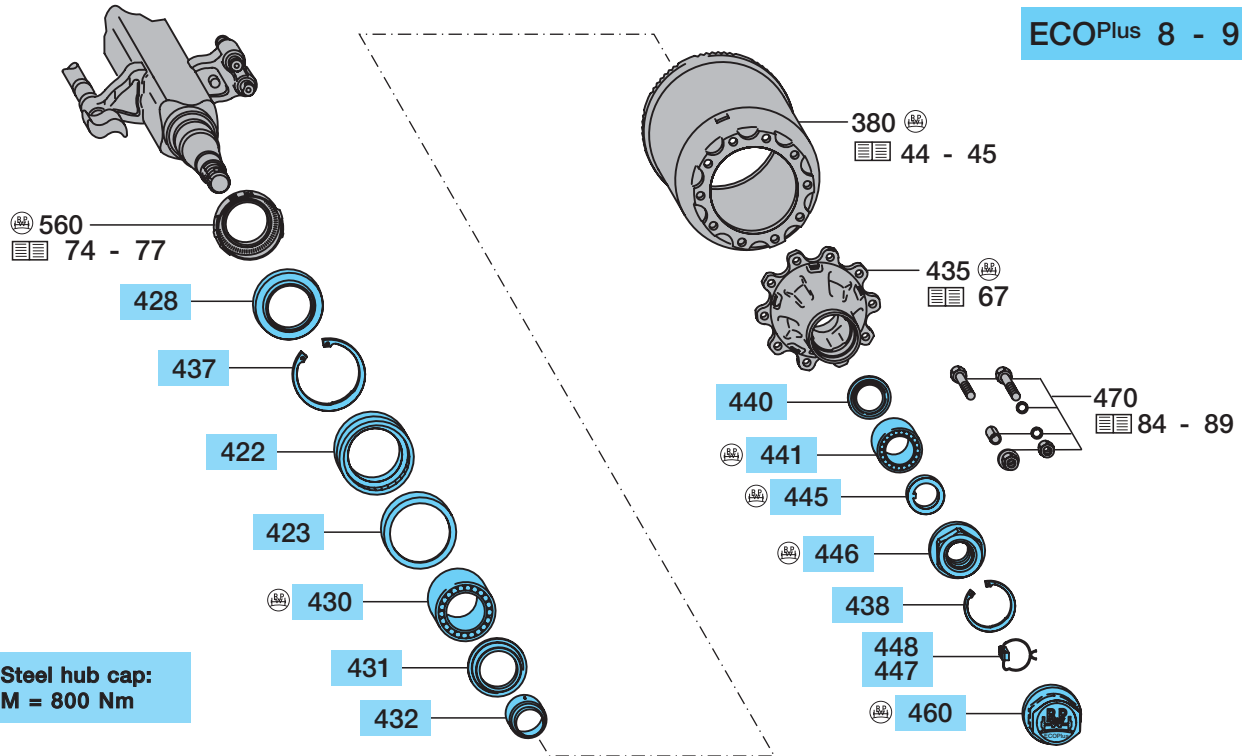

ECOPlus 10 - 12 t

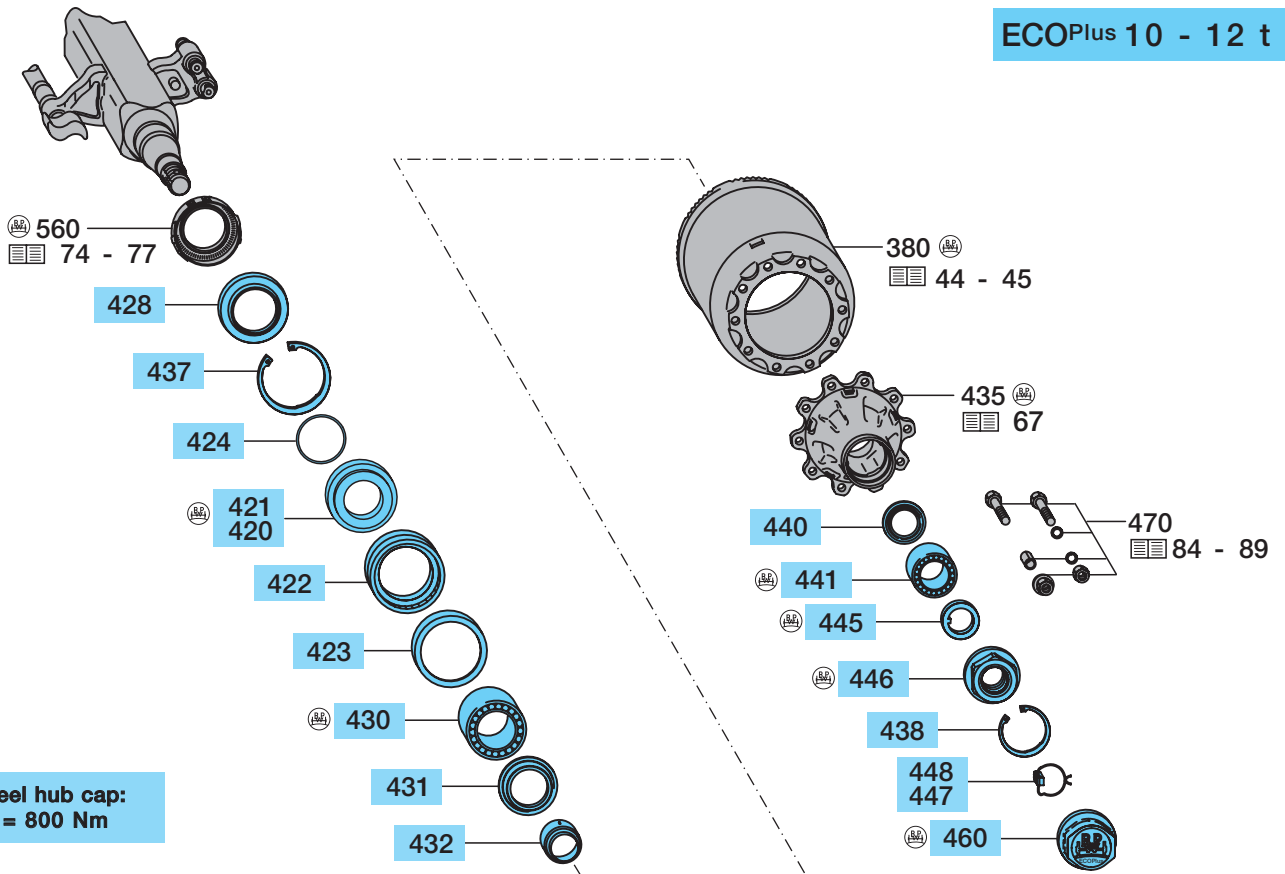

Grease filling, grease quantity and bearing adjustment see page 70

Hub caps with integrated Hubodometer see page 90 / 91

**ECOPlus hub system**

Item	Designation (Remark)	BPW Code no.	Dimension
		<b>H.. / KH.. ECOPlus 8 - 9 t --.48.---,---</b>	<b>H.. / KH.. ECOPlus 10 - 12 t --.50.---,---</b>
380	Brake drum	see page 44 / 45	see page 44 / 45
418	Repair kit roller bearing <b>without</b> axle nut and hub cap (item 420, 422, 423, 424, 430, 431, 441 - 445)	<b>09.801.06.26.0</b>	<b>09.801.06.27.0</b>
		<b>ECOPlus sealing system - 10 / 04</b>	<b>ECOPlus sealing system - 1 / 05</b>
420	Thrust washer cpl. (item 421, 422, 424)	-	05.370.07.65.0
421	Thrust washer	-	03.370.07.62.0 Ø 96 / 135 / 159 x 22
422	Lip seal	02.5664.68.00 Ø 120 / 157.5 x 20	02.5664.58.00 Ø 151 / 160 x 12.5
423	Ring	02.5683.80.00 Ø 151 / 157.6 x 20	02.5683.63.00 Ø 151 / 160 x 12.5
424	'O'-Ring	-	02.5678.00.00 Ø 100 x 3
428	Dirt seal	03.120.48.15.0 Ø 117.5 / 160 x 9.5	03.120.48.13.0 Ø 133 / 168 x 15
		<b>ECOSeal sealing system 10 / 04 -</b>	<b>ECOSeal sealing system 1 / 05 -</b>
420	Thrust washer cpl. (item 421, 424)	-	05.370.07.73.0
421	Thrust washer	-	03.370.07.72.0 Ø 96 / 117,5 / 132 x 22
422	ECOSeal seal	02.5664.74.00 Ø 117.5 x 158 x 17.5	02.5664.74.00 Ø 117.5 x 158 x 17.5
424	'O'-Ring	-	02.5678.00.00 Ø 100 x 3
428	Dirt seal	03.120.48.15.0 Ø 117.5 / 160 x 9.5	03.120.48.15.0 Ø 117.5 / 160 x 9.5
430	Roller bearing	02.6408.92.00 33118	02.6408.92.00 33118
431	Dust cover	03.010.93.34.0 Ø 94 / 149 x 8.5	03.010.93.34.0 Ø 94 / 149 x 8.5
432	Seal	03.120.45.15.0 Ø 67 / 95 x 49.5	03.120.45.16.0 Ø 67 / 93 x 90.5
435	Hub	see page 67	see page 67
437	Circlip	02.5606.58.90 158 x 4 / 472	02.5606.60.90 140 x 4 / 472 (- 1 / 05 ) 02.5606.58.90 158 x 4 / 472 ( 1 / 05 - )
438	Circlip	02.5606.22.90 122 x 4 / 472	02.5606.22.90 122 x 4 / 472
440	Thrust washer	03.370.26.24.0 Ø 71 / 108 x 8	03.370.26.24.0 Ø 71 / 108 x 8
441	Roller bearing	02.6407.67.00 33213	02.6407.67.00 33213
445	Washer	03.320.64.01.0 Ø 53 / 76 x 5.8	03.320.64.01.0 Ø 53 / 76 x 5.8
446	Axle nut	05.266.47.06.0 M 52 x 2 / SW 95	05.266.47.06.0 M 52 x 2 / SW 95
447	Locking piece	03.277.00.07.0	03.277.00.07.0
448	Locking ring	03.188.04.10.0	03.188.04.10.0
460	Hub cap (standard) Observe hub cap thread!	03.212.25.30.0* M 135 x 2 / SW 110 <b>03.212.25.31.0* M 136 x 2.5 / SW 110</b>	03.212.25.30.0* M 135 x 2 / SW 110 <b>03.212.25.31.0* M 136 x 2.5 / SW 110</b>

\* Modified cap thread from 09/00  
M 135 x 2 was changed to M 136 x 2.5  
Note thread size stamped on the cap!

## 5.4 Hubs

Conventional hub bearing system					
Item	Designation (Remark)	BPW Code no.			
H.. / R..					
	Hub cap thread	6.5 - 9 t --.06/08/09.----.---	10 - 12 t ---.10.----.---	13 - 14 t --.14.----.---	16 - 18 t ---.16.----.---
435	Hub (incl. item 436, page 65)				
	<b>280.5 / 335 / 10 x Ø 22 / 6 x Ø 21</b>				
	<b>HB.. Steel- and Alloy wheels</b>	M 115 x 2	03.275.66.23.0	-	-
	<b>220.5 / 275 / 8 x Ø 20</b>				
	<b>HS.. / HZ.. Steel wheels</b>	M 115 x 2	03.272.28.52.0	-	-
	<b>220 / 285 / 8 x Ø 20</b>				
	<b>HZ.. Japanese</b>	M 125 x 2	-	03.272.47.21.0	-
	<b>220 / 285 / 10 x Ø 20</b>				
	<b>HZ.. Japanese</b>	M 125 x 2	-	03.272.47.20.0	-
	<b>280.5 / 335 / 10 x Ø 22</b>				
	<b>HS.. Steel- and Alloy wheels</b>	M 115 x 2	03.272.30.41.0	-	-
	<b>HZ.. Steel wheels</b>	M 125 x 2	-	03.272.48.46.0	-
		M 115 x 2	03.272.30.49.0	-	-
	<b>HS.. MAXX</b>	M 135 x 3	-	-	03.272.62.32.0
	<b>HZ.. MAXX</b>	M 155 x 3	-	-	-
		M 115 x 2	03.272.30.56.0	-	03.272.80.18.0
	<b>HZ.. Alloy wheels</b>	M 125 x 2	-	-	-
		M 115 x 2	-	03.272.48.52.0	-
	<b>HS.. / HZ.. Steel wheels</b>	M 135 x 3 *	-	-	03.272.62.27.0 *
		M 150 x 2	-	-	03.272.62.35.0
		M 155 x 3	-	-	-
					03.272.80.14.0
Hub with M 135 x 3 internal thread is changed to hub with M 150 x 2 external thread (see also page 57).					

KH.. / KR..					
	Hub cap thread	KRBM 6408 --.65.----.---	6.4 - 9 t ---.06/08.----.---	10 - 12 t --.10.----.---	13 t --.14.----.---
435	Hub (incl. item 436, page 65)				
	<b>220.5 / 275 / 8 x Ø 22</b>				
	<b>KRB..</b>	M 115 x 2	03.272.28.35.0	03.272.28.47.0	-
		M 115 x 2	-	03.272.28.46.0	-
	<b>KH.. / KR..</b>	M 125 x 2	-	03.272.46.11.0	-
		M 135 x 3	-	-	03.272.60.03.0
	<b>175.5 / 225 / 10 x Ø 22</b>				
	<b>KH.. / KR..</b>	M 115 x 2	-	03.272.27.24.0	-
		M 125 x 2	-	03.272.44.24.0	-
	<b>280.5 / 335 / 10 x Ø 22</b>				
	<b>KHS.. 9010/3</b>	M 115 x 2	-	03.272.30.49.0	-

NH.. / NR..					
	Hub cap thread	6 - 9 t --.06/08.----.---	10 - 12 t ---.10.----.---	13 t --.14.----.---	
435	Hub (incl. item 436, page 65)				
	<b>160.5 / 205 / 6 x Ø 20</b>				
	<b>NRS.. / NRZ.. 6006 / 7006</b>	M 115 x 2	03.272.26.07.0	-	-
	<b>160.5 / 205 / 6 x Ø 18 / 2 x M 10</b>				
	<b>NRZ 6006 12" tyres</b>	M 115 x 2	03.272.26.10.0	-	-
	<b>220.5 / 275 / 8 x Ø 20 / 2 x M 10</b>				
	<b>NRS.. / NRZ..</b>	M 115 x 2	03.272.28.32.0	-	-
	<b>175.5 / 225 / 10 x Ø 22</b>				
	<b>NRS.. / NRZ.. / NHS.. / NHZ..</b>	M 115 x 2	03.272.27.20.0	-	-
		M 125 x 2	-	03.272.44.30.0	-
	<b>175.5 / 225 / 10 x Ø 22 / 2 x M 12</b>				
	<b>NR.. 13 t without ABS</b>	M 135 x 3	-	-	03.272.63.12.0





## 5.5 Hubs

ECO / ECO MAXX hub system				
Item	Designation (Remark)	BPW Code no.		
NH.. / NR.. ECO				
	Hub cap thread	6.4 - 9 t --.36 / 38.---,---	10 - 12 t --.40.---,---	Complete hub BPW Code no.
435	Hub (incl. item 436)			
	<b>160.5 / 205 / 6 x Ø 20</b>			
	<b>NRS.. / NRZ.. 6006 ECO</b>	M 125 x 2	03.272.26.13.0	-
	<b>NHZ.. 6006 ECO</b>	M 125 x 2	03.272.26.14.0	-
	<b>220.5 / 275 / 8 x Ø 20 / 2 x M 10</b>			
	<b>NRS.. / NRZ.. 6008 ECO</b>	M 125 x 2	03.272.28.64.0	-
	<b>NHZ.. 6008 ECO MAXX (Light weight)</b>	M 125 x 2	03.272.28.70.0	09.801.06.55.0
	<b>175.5 / 225 / 10 x Ø 22</b>			
	<b>N.S.. / N.Z.. ECO</b>	M 125 x 2	03.272.27.41.0	09.801.06.50.0
	<b>N.S.. / N.Z.. ECO MAXX (Light weight)</b>	M 125 x 2	03.272.27.48.0	09.801.06.54.0
	<b>N.Z.. ECO</b>	M 125 x 2	03.272.27.44.0	-
	<b>N.Z.. ECO</b>	M 135 x 2	-	03.272.44.34.0 09.801.06.52.0
	<b>N.Z.. ECO MAXX (Light weight)</b>	M 136 x 2.5 *	-	03.272.44.40.0 09.801.06.56.0
	<b>N.Z.. Alloy wheels</b>	M 135 x 2 *	-	03.272.44.35.0 -
436	Splined pin	02.6010.25.60	Ø 5x19.5 (for 8-holes hub Ø 20)	
		02.6010.35.60	Ø 6x19.5 (for 10-holes hub Ø 22)	

\* Modified cap thread from 09/00  
 M 135 x 2 was changed to M 136 x 2.5  
 Note thread size stamped on the cap!  
 03.212.25.33.0 = M 136 x 2.5 ECO MAXX

ECOPlus hub system					
Item	Designation (Remark)	BPW Code no.			
H.. ECOPlus					
	Hub cap thread	8 - 9 t --.48.---,---	10 - 12 t --.50.---,---	Complete hub BPW Code no.	
435	Hub				
	<b>280.5 / 335 / 10 x Ø 22</b>				
	HS.. ECOPlus Steel- and Alloy wheels HZ.. ECOPlus Steel wheels	M 135 x 2 *	03.272.32.05.0	-	-
		M 136 x 2,5 *	03.272.43.10.0 03.272.43.10.2 <sup>1)</sup>	-	09.801.06.07.0
	HZ.. ECOPlus Alloy wheels	M 136 x 2,5 *	-	03.272.43.12.0 03.272.43.23.2 <sup>1)</sup>	09.801.06.08.0
M 136 x 2,5		-	03.272.43.15.0 03.272.43.25.2 <sup>1)</sup>	09.801.06.97.0	

<sup>1)</sup> New ECOPlus hubs with end digit **2** can only be used in conjunction with the new ECOPlus seal (02.5664.74.00).

\* Modified cap thread from 09/00  
M 135 x 2 was changed to M 136 x 2.5  
Note thread size stamped on the cap!  
03.212.25.31.0 = M 136 x 2.5 ECOPlus

KH.. ECOPlus					
	Hub cap thread	8 - 9 t --.48.---,---	10 - 12 t --.50.---,---	Complete hub BPW Code no.	
435	Hub				
	<b>220.5 / 275 / 8 x Ø 22</b>				
	KH.. ECOPlus	M 136 x 2,5 *	03.272.46.28.0 03.272.46.28.2 <sup>1)</sup>	-	09.801.06.69.0
		M 136 x 2,5 *	-	03.272.46.25.0 03.272.46.31.2 <sup>1)</sup>	09.801.06.61.0
	KHZ.. ECOPlus Alu-Räder	M 136 x 2,5 *	-	03.272.46.26.0 03.27246.32.2 <sup>1)</sup>	-
	<b>175.8 / 225 / 10 x Ø 22</b>				
	KH.. ECOPlus	M 136 x 2,5 *	-	03.272.44.40.0 03.272.44.43.2 <sup>1)</sup>	09.801.06.60.0
	<b>280.5 / 335 / 10 x Ø 22</b>				
KH.. 9010/3 ECOPlus	M 135 x 2 *	03.272.32.05.0	-	-	
	M 136 x 2,5 *	03.272.43.10.0 03.272.43.10.2 <sup>1)</sup>	-	09.801.06.07.0	

<sup>1)</sup> New ECOPlus hubs with end digit **2** can only be used in conjunction with the new ECOPlus seal (02.5664.74.00).  
Further types upon request.

\* Modified cap thread from 09/00  
M 135 x 2 was changed to M 136 x 2.5  
Note thread size stamped on the cap!  
03.212.25.31.0 = M 136 x 2.5 ECOPlus

5.7 Grease filling, bearing adjustment

H  
K  
N

Conventional hub bearing system

Grease filling per wheel hub

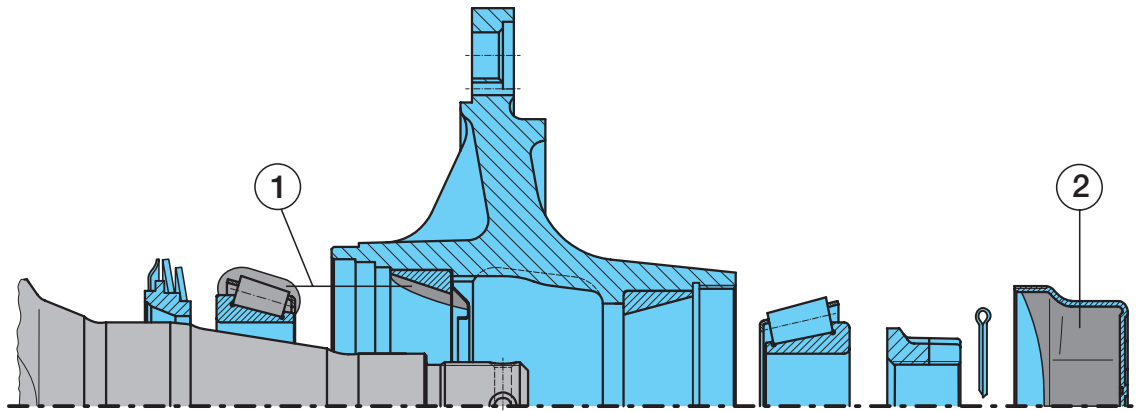

Clean taper roller bearings (using diesel oil) thoroughly, dried, check for re-useability and re-grease.

		BPW longlife roller bearing grease ECO-Li 91, quantity per tapered roller bearing			
		① inner		② outer	
Axle load	Axle type	Roller bearing	Quantity	Roller bearing	Quantity
6400 kg	KRBM 6498	33215	170 g	32310	290 g
6000 - 9000 kg	H.. 6.5 - 9 t K.. 6.4 - 9 t N.. 6 - 9 t	33116	170 g	32310	290 g
10000 - 12000 kg	H.. 10 - 12 t K.. 10 - 12 t N.. 10 - 12 t	33118	180 g	33213	320 g
13000 - 14000 kg	H.. 13 - 14 t K.. 13 t N.. 13 t	32219	240 g	33215	500 g
16000 - 18000 kg	H.. 16 - 18 t	32222	400 g	32314	800 g

① Work **BPW longlife roller bearing grease ECO-Li 91** into the spaces between the tapered rollers and the races. Apply remainder to outer race of the hub.

② The bearing grease for the outer tapered roller bearing is pressed into the bearing as the hub cap filled with grease is screwed on.

**Bearing adjustment**

1. Unscrew the hub cap.
2. Remove the axle nut split pin.
3. Tighten the axle nut using a torque wrench to 150 Nm while simultaneously turning the wheel hub. (When using the normal axle nut wrench (tool kit), tighten the axle nut until the wheel hub race is slightly braked).
4. Turn the axle nut back to the next possible pin hole. Should they be in line turn back to the next hole (30° at the maximum).
5. Insert the split pin and bend slightly outwards.
6. Refill the hub cap as required with **BPW longlife roller bearing grease ECO-Li 91**, grease thread of the hub cap all round, screw in and tighten to the prescribed tightening torque.

## ECO hub system

### Grease filling per wheel hub

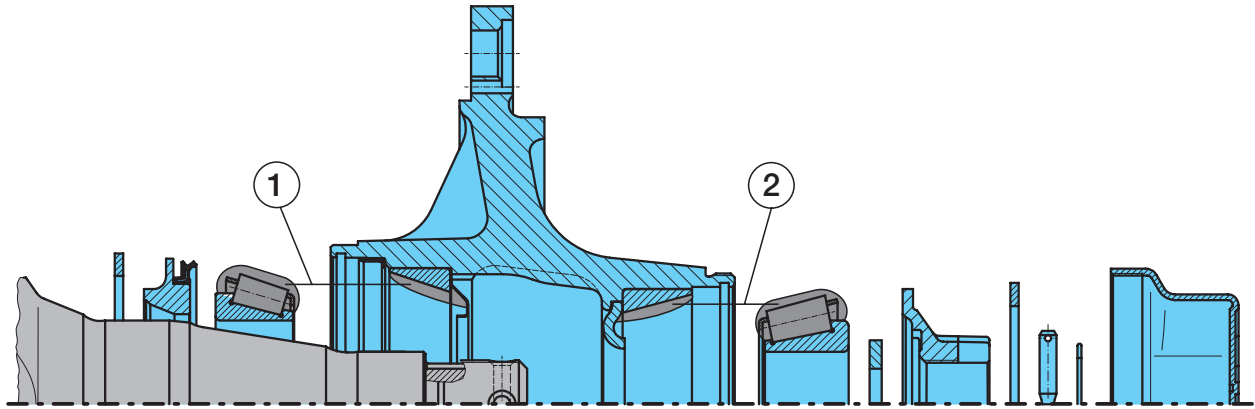

The BPW ECO hub system is designed for longlife lubrication (500,000 km or 3 years under normal conditions). Thereafter clean taper roller bearings (using diesel oil) thoroughly, dried, check for re-useability and re-grease (observe the current BPW maintenance instructions).

		BPW longlife roller bearing grease ECO-Li 91, quantity per tapered roller bearing			
		① inner		② outer	
Axle load	Axle type	Roller bearing	Quantity	Roller bearing	Quantity
6000 - 9000 kg	H.. 6.5 - 9 t ECO K.. 6.4 - 9 t ECO N.. 6 - 9 t ECO	33116	120 g	32310	120 g
10000 - 12000 kg	H.. 10 - 12 t ECO K.. 10 - 12 t ECO N.. 10 - 12 t ECO	33118	170 g	33213	120 g
13000 - 14000 kg	H.. 13 - 14 t ECO	32219	230 g	33215	150 g

① and ② Work BPW longlife roller bearing grease ECO-Li 91 thoroughly into the spaces between the tapered rollers and the races. Apply remainder to outer races in the hub.  
Renew the lip seal and smear contact area with BPW longlife roller bearing grease ECO-Li 91.

### Bearing adjustment

1. Unscrew the hub cap.
2. Remove the locking bolt with spring ring.
3. By turning wheel hub simultaneously, tighten axle nut with torque wrench to 150 Nm and turn back to the next possible securing hole, max. 15°. - Because of the asymmetric crown of the axle nut the next securing hole will be reached after max. 15°.
4. Re-assemble locking bolt with spring ring.
5. Grease thread of the hub cap around with ECO-Li 91, screw on hub cap and tighten to the prescribed tightening torque (steel hub cap 800 Nm, alloy hub cap 350 Nm).

BPW longlife roller bearing grease ECO-Li 91	Container	BPW Code no.
	0.4 kg Cartridge	02.1040.34.00
2.5 kg Bucket	02.1040.30.00	
5 kg Bucket	02.1040.31.00	
10 kg Bucket	02.1040.32.00	
50 kg Drum	02.1040.33.00	

5.9 Grease filling, bearing adjustment

**ECOPlus hub system**

**Grease filling per wheel hub**

Fig. ECOPlus 8 - 9 t

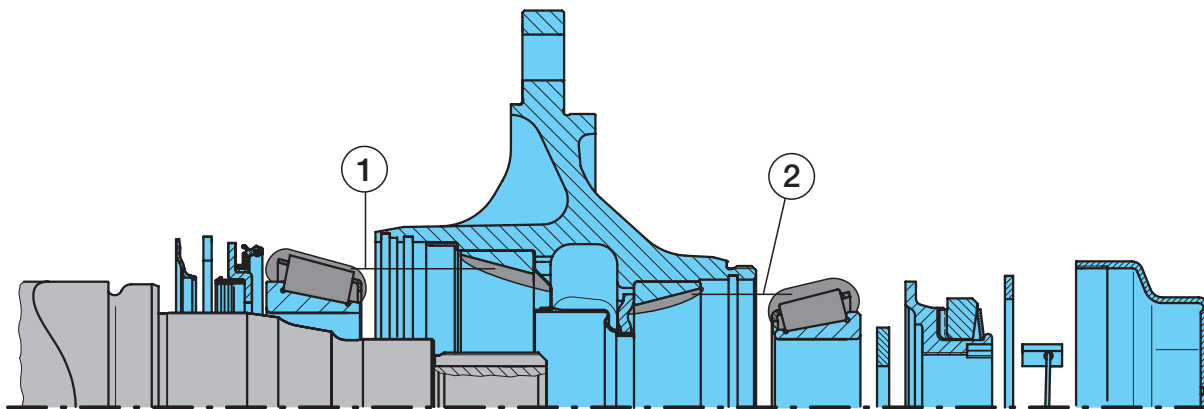

The ECOPlus hub system is designed for the use of longlife grease. On expiry of the guarantee, the roller bearings, the inside of the hub and the seals are to be thoroughly cleaned (with diesel oil), dried, checked to see if they can be reused; and regreased every three years when used off-road, or every 5 years when used on the road, within Europe (or every year when off-road and every two years when on the road outside of Europe) (observe the current BPW maintenance instructions). Spray the stub-axle bearing seats with **BPW ECO Assembly and Protection Spray** (BPW no. 02.3521.12.00).

		BPW longlife roller bearing grease ECO-LiPlus, quantity per tapered roller bearing			
		① inner		② outer	
Axle load	Axle type	Roller bearing	Quantity	Roller bearing	Quantity
8000 - 12000 kg	H.. 8 - 12 t ECOPlus K.. 8 - 12 t ECOPlus	33118	170 g	33213	120 g

① and ② Work BPW longlife roller bearing grease ECO-LiPlus thoroughly into the spaces between the tapered rollers and the races. Apply remainder to outer races in the hub.  
Renew the lip seal and smear contact area with **BPW longlife roller bearing grease ECO-LiPlus**.

**Bearing adjustment**

1. Unscrew the hub cap.
2. Remove the hooked spring ring with a wedge from the axle nut.
3. Use a spanner to tighten the axle nut whilst at the same time turning the wheel hub, until the axle nut torque limiter operates (do not use an impact driver).
4. Fit the retaining key in the groove between the axle stub and the nut (do not reset the axle nut).
5. Insert the hooked spring ring, depending on the version, behind the flange on the axle nut or in the thread on the axle stub.
6. Screw on hub cap and tighten to 800 Nm.

BPW longlife roller bearing grease ECO-LiPlus	Container	BPW Code no.
	0.4 kg Cartridge	02.1040.45.00
	5 kg Bucket	02.1040.47.00
	25 kg Bucket	02.1040.49.00
	50 kg Drum	02.1040.50.00

## Grease sprays for greasing taper roller bearings 5.10

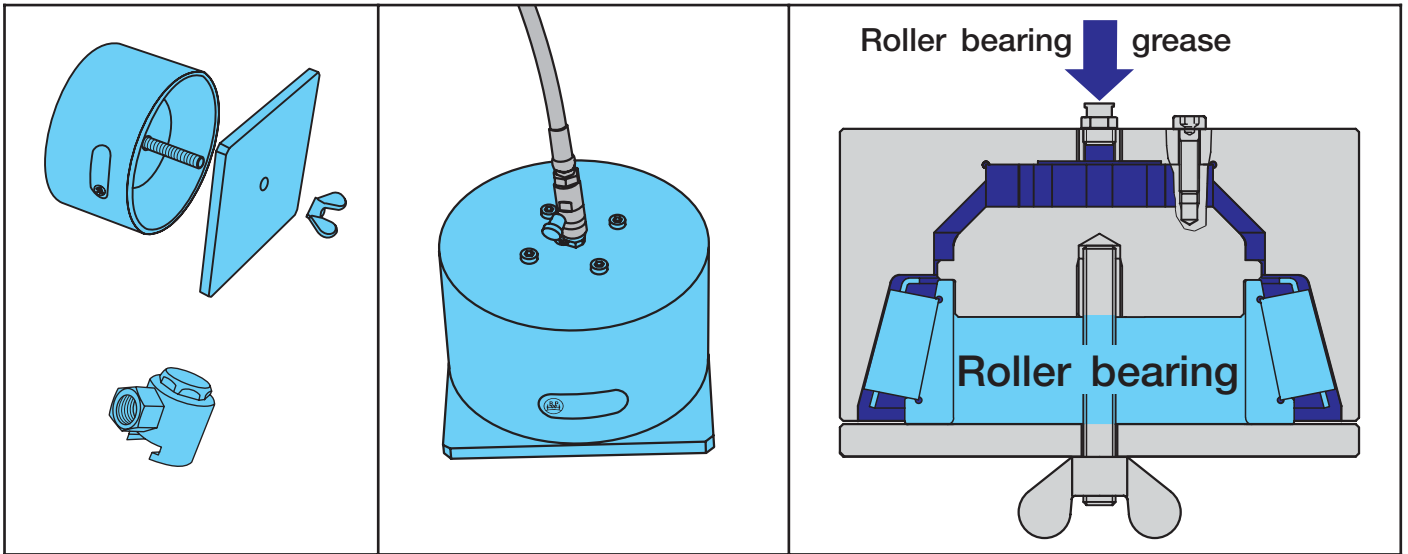

Grease spray	for taper roller bearing	BPW Code no. grease spray loose	BPW Code no. complete set
	33116	16.076.22935	99.00.000.9.54
	32310	16.072.22935	
	33118	16.062.22935	99.00.000.9.55
	33213	16.068.22935	
Complete set including adapter for flat grease nipple			
Adapter for flat grease nipple			BPW Code no.
			15.069.22935

H

K

N

6 ABS parts

H  
K  
N

General

ABS

In the anti-lock brake system (ABS), the wheel movement is recorded using a proximity-type arrangement with an exciter ring attached to the hub and a sensor (speed sensor) that generates the pulses.

As a result, the wheel speed of each wheel is continuously sent to the central control ECU. This runs a complex program for processing the received information about the movement of the wheel as well as for calculating and performing logical operations on the control signals. Using the pressure control valves assigned to each wheel, it adjusts the air pressure and therefore the braking of each individual wheel (depending on the ABS system).

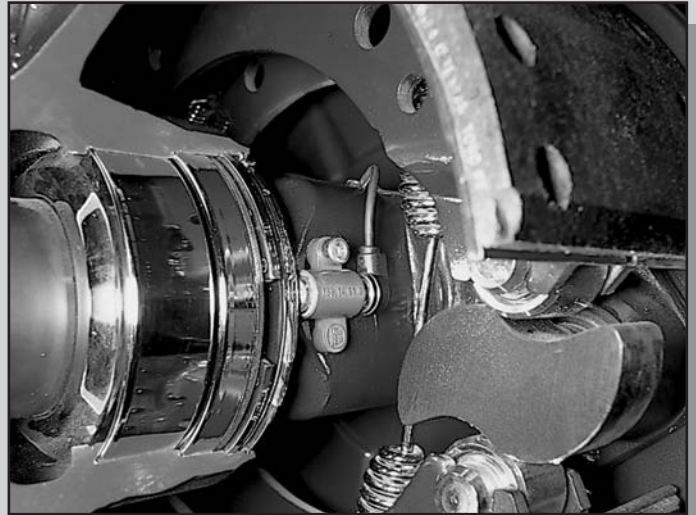

Almost all BPW axles can be retrofitted with ABS without problems. To do this, simply take the exciter ring, sensor holder, sensors and fastening parts contained in the retrofit kit and attach them to the axle in accordance with the supplied installation drawing, then connect them to the vehicle electronic system.

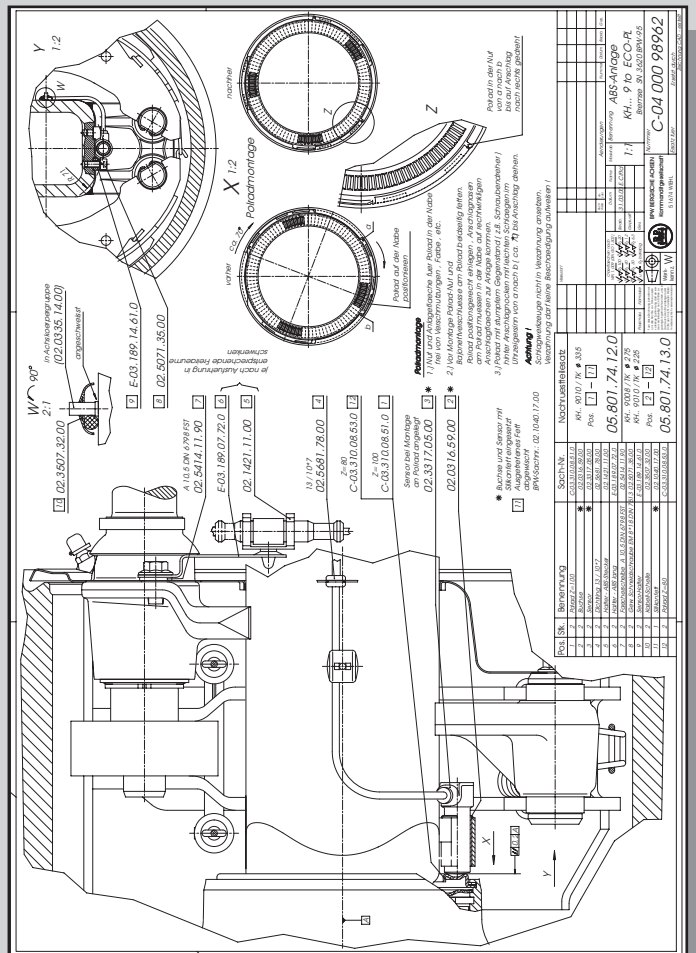



**Pressed-on sheet metal exciter rings**

For replacement purposes, pressed-on sheet metal exciter rings are replaced by solid exciter rings.

To do this, heat the new solid exciter ring to approx. 80 to 120 °C and shrink-fit.

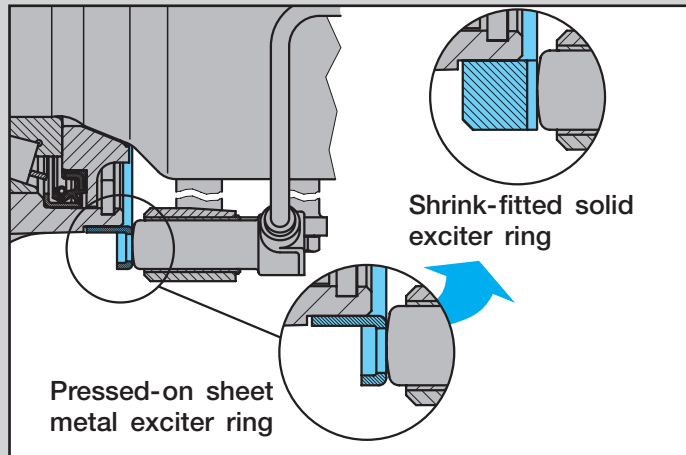

**Protected ABS sensor plug connection**

Since 1997 BPW trailer axles of the H-series are available with the new innovative ABS sensor plug connection.

With this design the sensor plug, which sits in a recess in the brake dust covers, is optimally protected against in-transit damage.

The connection of the ABS cables (sensor cable / connection cable to the control unit) is made in the same way as with a normal plug socket by simply inserting the plug into the bracket located in the brake anchor plate.

The absolutely firm attachment of the sensor bracket to the brake anchor plate ensures that no damage whatsoever can occur to these ABS components even under the most arduous deployment conditions (assuming that the sensor cable is laid properly).

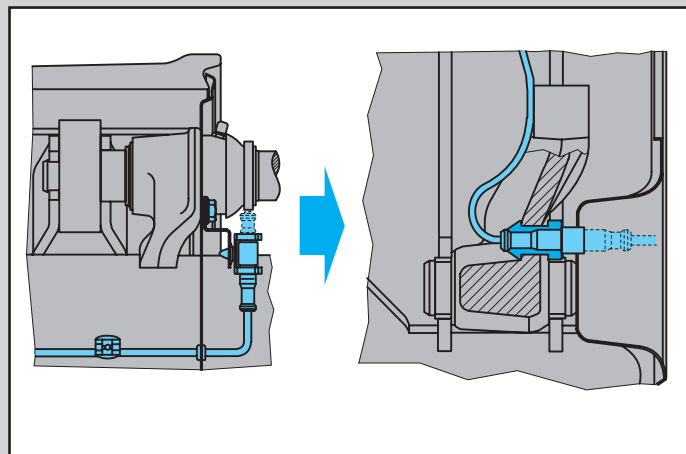

H

K

N

6.1 ABS parts

H

H. / R..			
<p><b>A</b></p>	<p><b>B</b></p>	<p><b>C</b></p>	<p><b>D</b></p>

Retrofit part sets see page 80

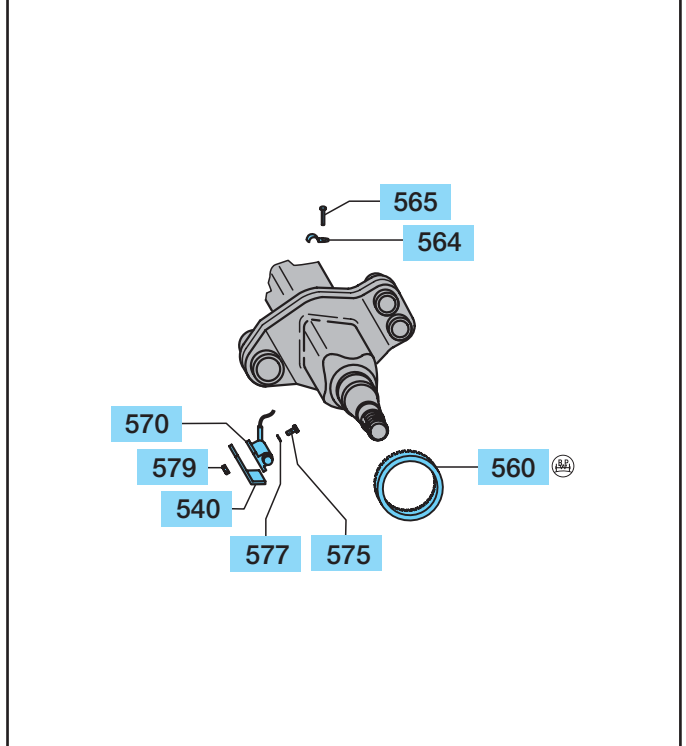
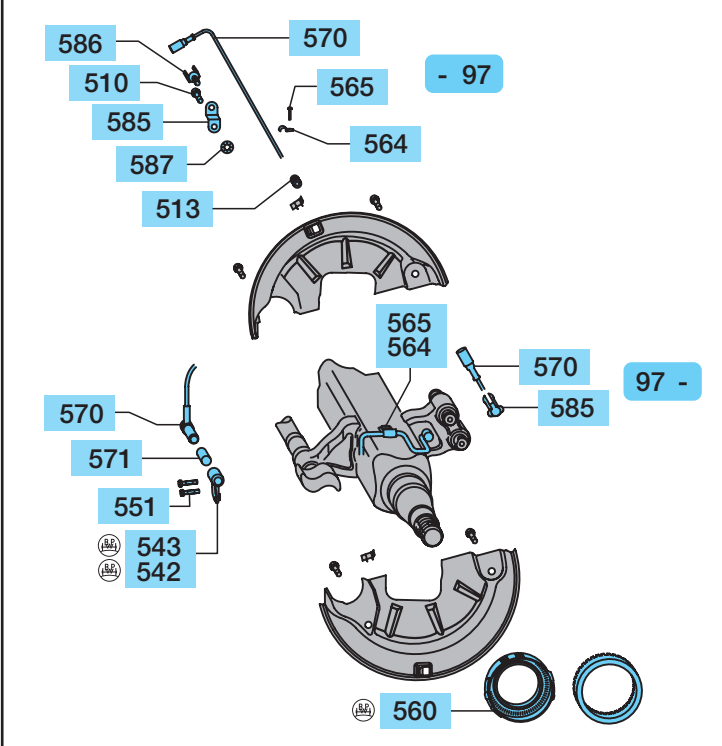

for ABS Wabco / Bosch /  
Grau-Girling DGX /  
Grau-Girling MGX100 / Knorr

for ABS Grau-Girling MGX-2

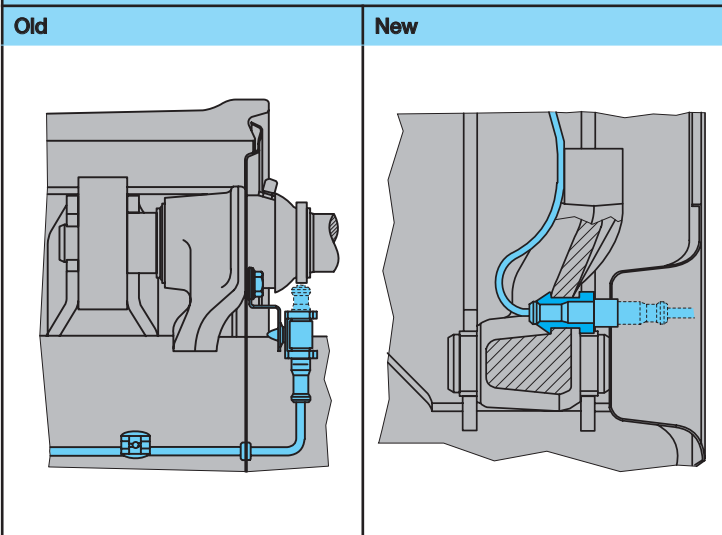

**Protected ABS sensor plug connection**  
 Since 1997 BPW trailer axles of the H-series are available with the new innovative ABS sensor plug connection. With this design the sensor plug, which sits in a recess in the brake dust covers, is optimally protected against in-transit damage.  
 The connection of the ABS cables (sensor cable / connection cable to the control unit) is made in the same way as with a normal plug socket by simply inserting the plug into the bracket located in the brake anchor plate.  
 The absolutely firm attachment of the sensor bracket to the brake anchor plate ensures that no damage whatsoever can occur to these ABS components even under the most arduous deployment conditions (assuming that the sensor cable is laid properly).

H.. / R..							
Item	Designation (Remark)	BPW Code no.	Dimension				
<b>Sensor bracket for ABS Wabco / Bosch / Grau-Girling DGX / Grau-Girling MGX 100 / Knorr</b>		<b>H.. 6.5 - 9 t □ 120 16° Brake position H.. 6.5 - 9 t □ 120 30° Brake position H.. 10 - 14 t □ 150</b>			<b>H.. 10 t □ 120 16° Brake position H.. ECO<sup>Plus</sup> 10 t □ 120 16° Brake position</b>		
542	Sensor bracket (right)	03.189.07.10.0	L 25, H 17	Fig. A	03.189.11.66.0	L 48, H 22	Fig. A
543	Sensor bracket (left)	03.189.07.09.0	L 25, H 17		03.189.11.67.0	L 48, H 22	
542	Sensor bracket (right)	03.189.07.58.0	L 37.5, H 14	Fig. A			
543	Sensor bracket (left)	03.189.07.59.0	L 37.5, H 14				
551	Locking screw	02.5071.23.00	M 8 x 20 (4x)		02.5071.23.00	M 8 x 20 (4x)	
		<b>H.. ECO<sup>Plus</sup> 8 - 9 t □ 120 16° Brake position</b>					
542	Sensor bracket	03.189.14.61.0	Fig. B				
551	Locking screw	02.5071.35.00	M 8 x 18 (2x)				

		<b>H.. 9 t □ 150</b>			
542	Sensor bracket (right)	05.189.07.18.0	Fig. C		
543	Sensor bracket (left)	05.189.07.19.0			
		<b>R.. 6.5 - 9 t ○ 127</b>		<b>R.. 10 - 12 t ○ 127</b>	
540	Attachment plate	03.080.04.01.0	H 21, α 10°	03.080.03.38.0	H 30, α 5°
542	Sensor bracket	03.189.07.87.0	Fig. D	03.189.07.87.0	03.189.07.87.0
551	Cylinder head screw		02.5015.00.80	M 6 x 16 - 8.8 (4x)	
553	Spring washer		02.5601.06.90	A 6 / 128 (4x)	
				<b>H.. 16 t □ 150</b>	

Item	Designation (Remark)	Wabco / Bosch for ABS Grau-Girling DGX Grau-Girling MGX 100 / Knorr	for ABS Grau-Girling MGX-2
560	Ring (Exciter ring)		
	6.5 - 9 t □ 120 / ○ 127	03.310.08.15.0	03.310.08.28.0
	8 - 9 t ECO <sup>Plus</sup> □ 120	03.310.08.51.0	-
	6.5 - 9 t □ 150	03.310.09.31.0	03.310.09.32.0
	10 - 12 t □ 120 / 150 / ○ 127	03.310.08.14.0	03.310.08.31.0
	10 - 12 t ECO <sup>Plus</sup> □ 120	03.310.08.54.0	-
	13 - 14 t □ 150	03.310.08.25.0	-
	13 - 14 t □ 150	03.310.09.27.0	-
	16 t □ 150	03.310.09.36.0	-
564	Clip (for drive pin)	02.0326.32.00	02.0326.32.00
	Clip (Clip for welded bolt)	02.3507.32.00	02.3507.32.00
565	Drive pin	02.6005.25.40	02.6005.25.40
570	Sensor	02.3317.05.00	02.3317.03.00
571	Bush	02.0316.59.00	-
575	Cylinder head screw	-	02.5015.01.80
		-	02.5015.02.80
577	Spring washer	-	02.5601.05.90
579	Lock nut	-	02.5220.06.82
		<b>Old Conventional ABS sensor plug connection</b>	<b>New Protected ABS sensor plug connection</b>
585	Support	03.189.07.35.0	03.189.13.90.0
586	Support	02.1421.11.00	-
587	Serrated lock washer	02.5414.11.90	-

6.1 ABS parts

K

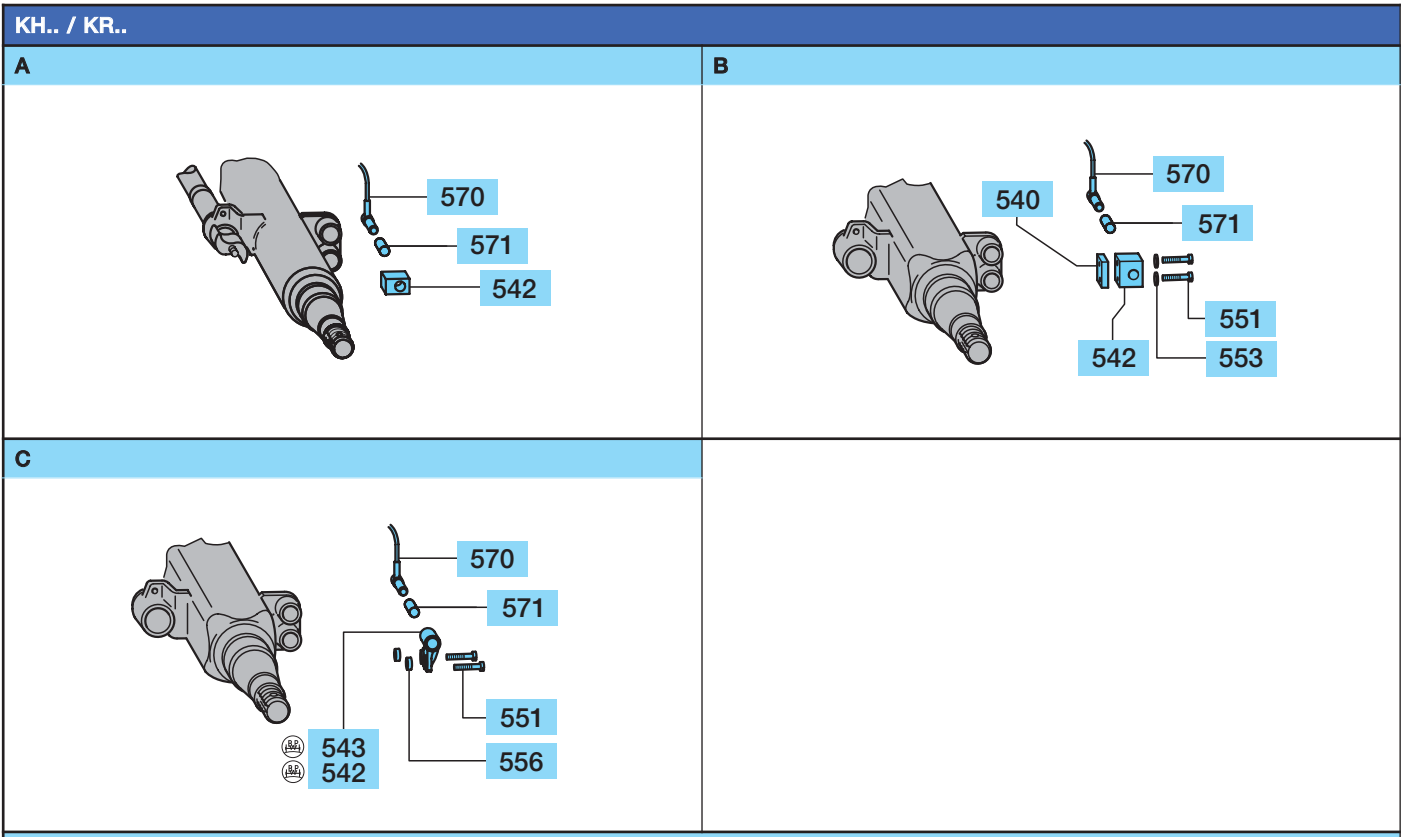

Retrofit part sets see page 81

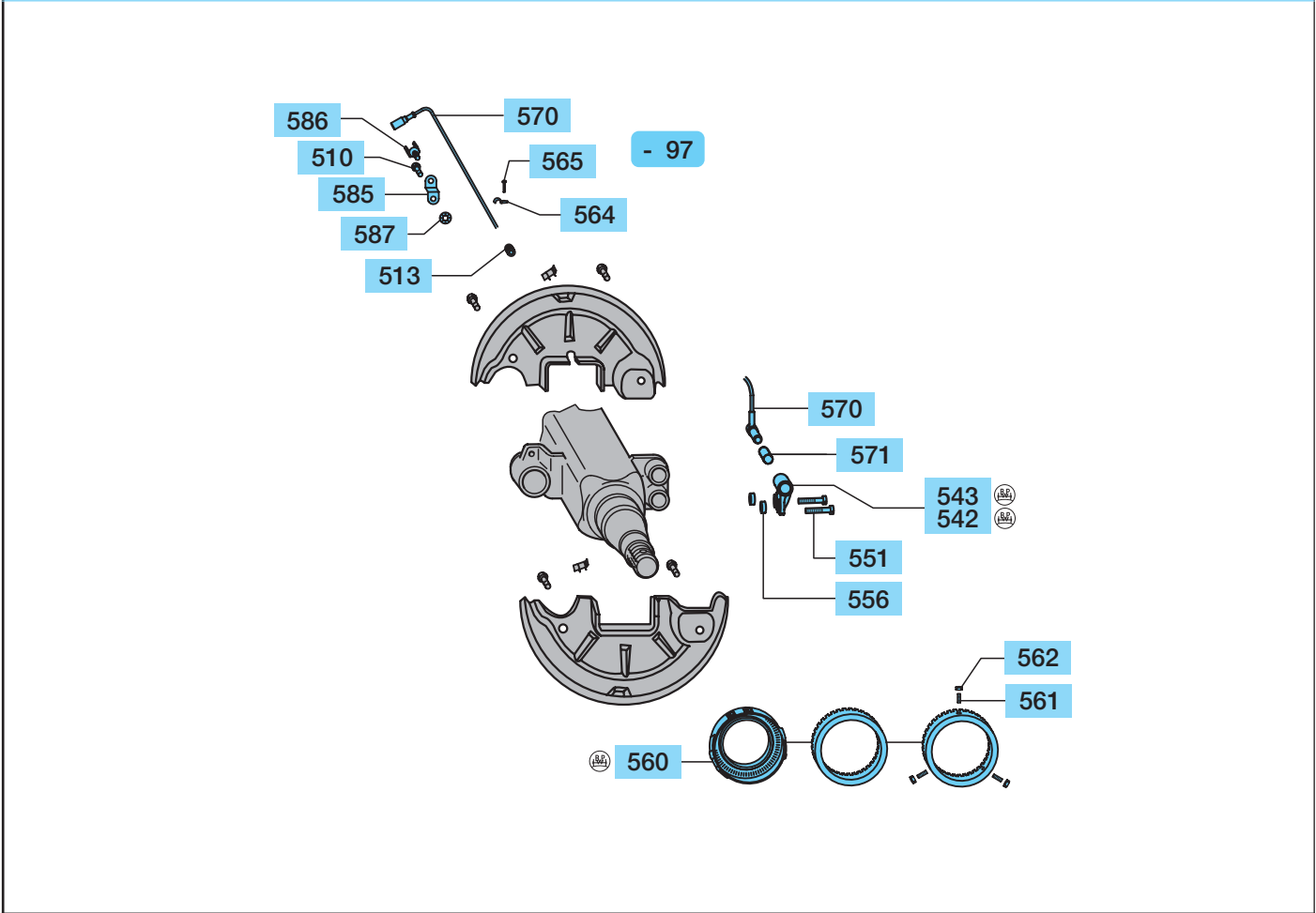

KH.. / KR..				
Item	Designation (Remark)	BPW Code no.	Dimension	
		<b>Sensor bracket for ABS Wabco / Bosch / Grau-Girling DGX / Grau-Girling MGX 100 / Knorr</b>		<b>Axle type</b>
<b>Fig. A</b>				
542	Block	03.221.56.16.0		<b>KRBM 6408</b> 30.65.542....
	Sensor bracket	05.189.05.19.0		<b>KRB.. 6408</b> 30.06.542....
<b>Fig. B</b>				
540	Attachment plate	03.080.03.09.0 03.080.03.05.0 03.080.03.03.0 03.080.03.16.0		<b>KR.. 8 - 9 t</b> <b>KH.. 10 t</b> <b>KR.. 10 - 12 t</b> <b>KM.. 13 t</b>
542	Block	03.221.67.21.0		<b>KR.. 8 - 12 t / KH.. 10 t</b>
	Sensor bracket	05.189.06.15.0		<b>KM.. 13 t</b>
	Sensor bracket	03.189.07.87.0		<b>KR 8 - 12 t / 3</b>
551	Hexagon screw	02.5021.10.80	M 6 x 35 / 931	<b>KR.. 8 - 12 t / KH.. 10 t</b>
	Cylinder head screw	02.5015.00.80	M 6 x 16 / 912	<b>KR 8 - 12 t / 3</b>
	Cylinder head screw	02.5015.06.80	M 6 x 20 / 912	<b>KM.. 13 t</b>
553	Spring washer	02.5601.06.90	A 6 / 127	
<b>Fig. C</b>				
542	Sensor bracket (right)	03.189.07.58.0		<b>KH.. 8 - 12 t</b>
543	Sensor bracket (left)	03.189.07.59.0		
551	Self-tapping screw	02.5047.14.00	AM 8 x 20 / 7513	<b>KH.. 8 - 9 t</b>
		02.5047.16.00	AM 8 x 30 / 7513	
556	Sleeve	03.200.71.06.0	Ø 8.5 / 15 x 10	<b>KH 10 t</b>
560	Ring (Exciter ring)	80-teeth 03.310.08.18.0 100-teeth 03.310.08.15.0 100-teeth 03.310.08.51.0 80-teeth 03.310.08.26.1 80-teeth 03.310.08.24.1 100-teeth 05.310.08.50.1 80-teeth 05.310.08.44.1 80-teeth 03.310.08.34.0	Ø 152/170x15 Ø 152/170x15 Ø 150/180x19.5 Ø 170/176/194x17.5 Ø 170/176/194x17.5/3xM6 Ø 150/176/180x18.5 Ø 150/176/180x19.5 Ø 194/213x15	<b>KH.. / KR.. 6.4 - 9 t</b> <b>KH.. / KR.. 8010/3, 9010/3</b> <b>KH.. 8 - 9 t ECO<sup>Plus</sup></b> <b>KH 10008 / KR 10008 - 12008</b> <b>KH 10010 / KR 10010 - 12010</b> <b>KH.. / KR.. 10010/3</b> <b>KH.. 10 - 12 t ECO<sup>Plus</sup></b> <b>KM 13008</b>
561	Grub screw	02.5018.09.08	M 6x15/914-45H	<b>KH 10010 / KR 10010 - 12010</b>
562	Hexagon nut	02.5202.10.82	M 6/934	
564	Clip (for drive pin)	02.0326.32.00	1 x 6 / 72571-St	
	Clip (Clip for welded bolt)	02.3507.32.00		
565	Drive pin	02.6005.25.40	Ø 4 x 10 / 1476-St	
570	Sensor	02.3317.05.00		
571	Bush	02.0316.59.00		
585	Support	03.189.07.72.0		
586	Support	02.1421.11.00		
587	Serrated lock washer	02.5414.11.90	A 10.5 / 6798	

6.1 ABS parts

N

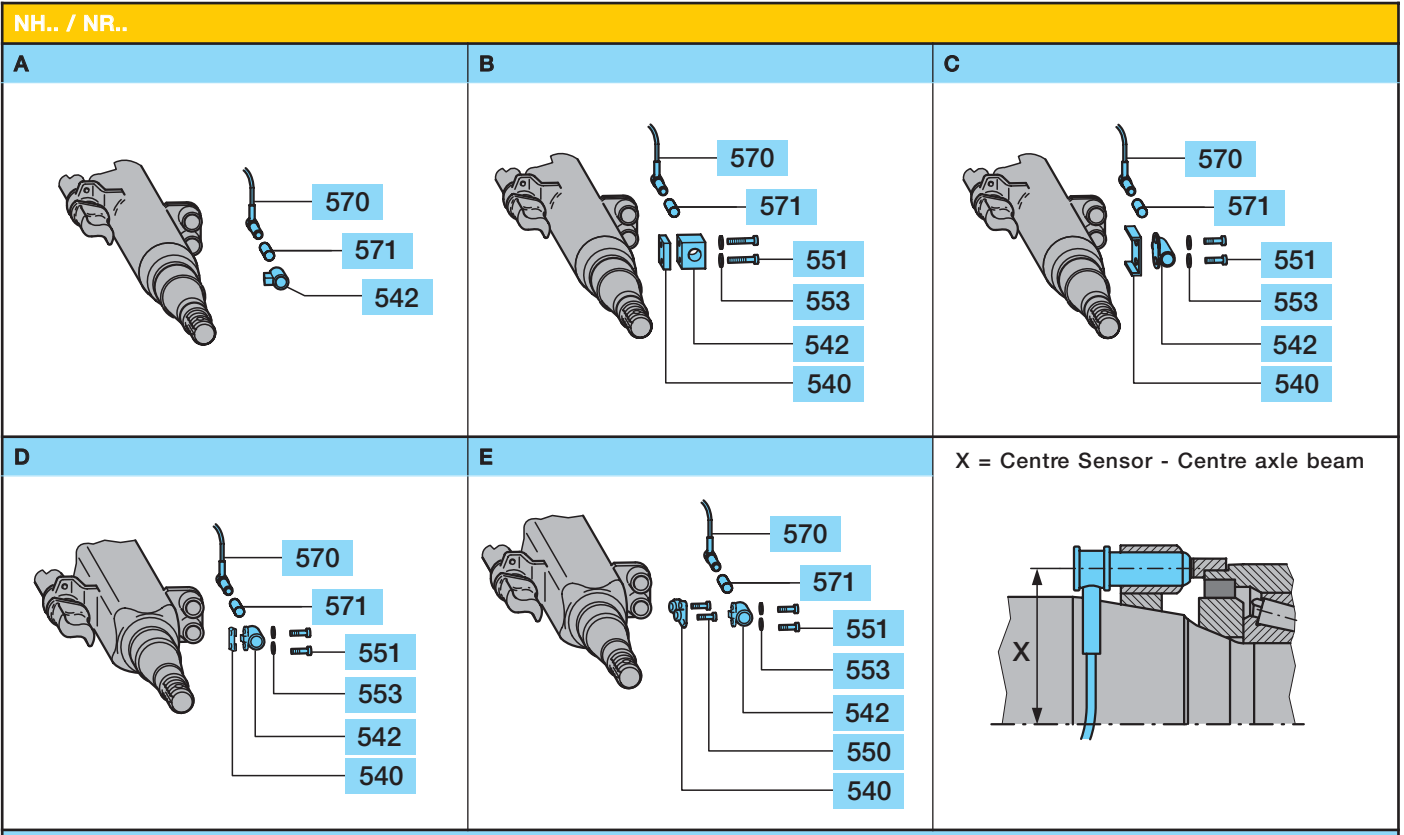

Retrofit part sets see page 81

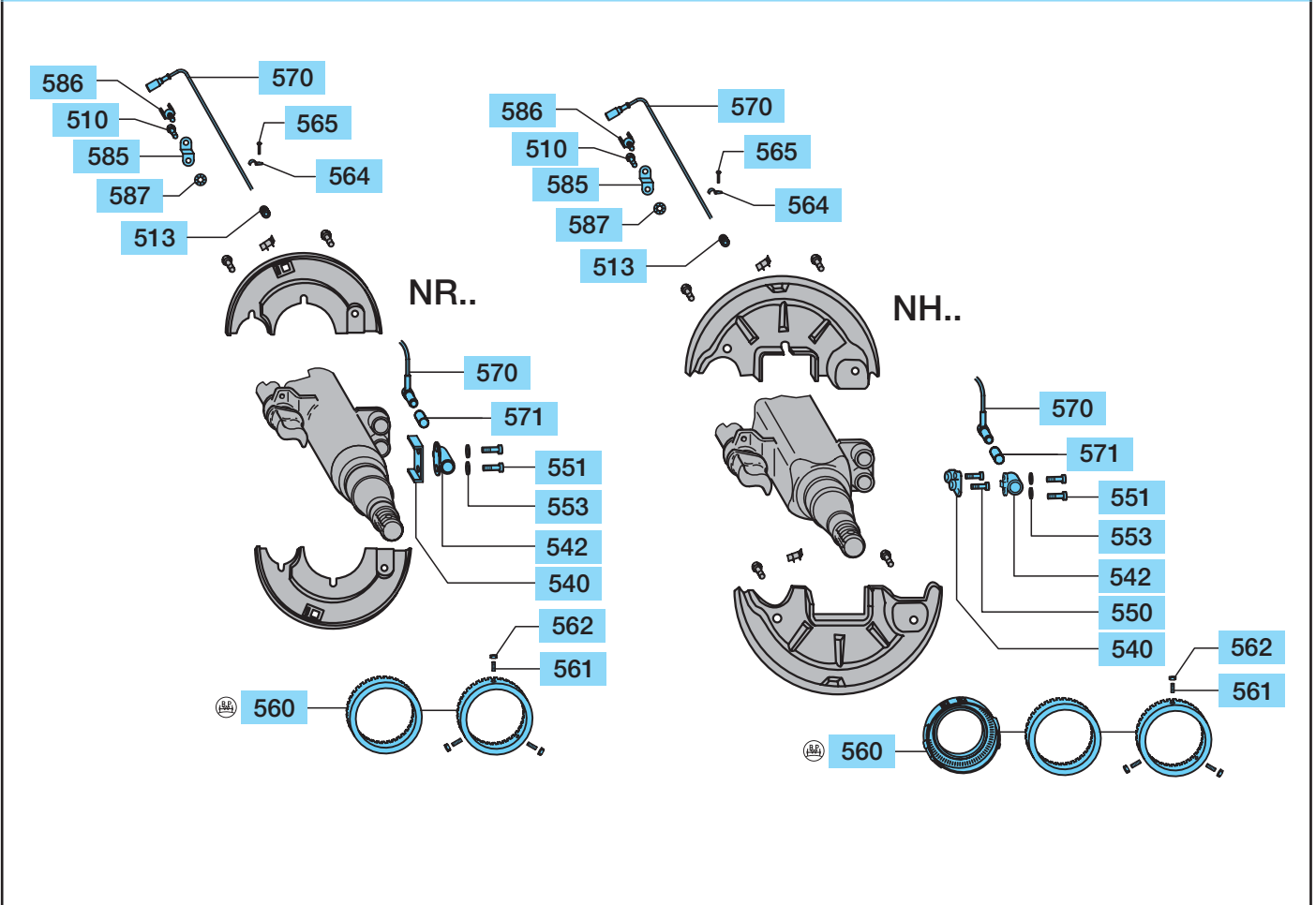

NH.. / NR..					
Item	Designation (Remark)	BPW Code no.	Dimension		
Year of manufacture		Axle type		X	suitable for exciter ring
<b>Fig. A</b>					
542	Sensor bracket	1982 - 1989	05.189.06.23.0 NR.. 6006 05.189.05.19.0 NR.. 6010 / 6410 05.189.05.19.0 NR.. 8010 / 9010 Brake drum 295 mm	77 81 81	03.310.08.27.0 03.310.08.18.0 03.310.08.18.0
<b>Fig. B</b>					
540	Attachment plate	1985 - 1989	03.080.03.03.0 NR.. 10010 - 12010 Brake drum 295 mm	93	03.310.08.24.1
542	Block		03.221.67.21.0		
551	Hexagon screw		02.5021.10.80 M 6 x 35 / 931		
553	Spring washer		02.5601.06.90 A 6 / 127		
<b>Fig. C</b>					
540	Attachment plate	1990 - 1995 1982 - 1989 X = see Fig. 1990 - 1995 1982 - 1989 1990 - 1995	03.080.03.20.0 NR.. 6006 / 6408 / 6410 03.080.04.01.0 NR.. 8010 / 9010 Brake drum 260 mm 03.080.04.01.0 NR.. 8010 / 9010 03.080.03.20.0 NR.. 10010 - 12010 Brake drum 260 mm 03.080.03.20.0 NR.. 10010 - 12010	77 81 81 81 81	03.310.08.27.0 03.310.08.18.0 03.310.08.18.0 03.310.08.44.1 03.310.08.44.1
542	Sensor bracket		03.189.07.87.0		
551	Cylinder head screw		02.5015.00.80 M 6 x 16 / 912		
553	Spring washer		02.5601.06.90 A 6 / 127		
<b>Fig. D</b>					
540	Shaped plate		03.160.23.01.0 NH.. 6006 / 6408 / 6410	77	03.310.08.43.0
542	Sensor bracket		03.189.12.02.0		
551	Cylinder head screw		02.5015.94.80 M 6 x 12 / 912		
553	Spring washer		02.5601.06.90 A 6 / 127		
<b>Fig. E</b>					
540	Sensor bracket		03.189.11.77.0 NH.. 8010 / 9010 NH.. 10010 - 12010	81 81	03.310.08.18.0 03.310.08.44.1
542	Sensor bracket		03.189.07.87.0		
550	Self-tapping screw		03.341.00.05.0 M 8 x 20		
551	Cylinder head screw		02.5015.00.80 M 6 x 16 / 912		
553	Spring washer		02.5601.06.90 A 6 / 127		

560	Ring (Exciter ring) utilization see above	<b>ABS Wabco / Bosch / Grau-Girling DGX / Grau-Girling MGX 100 / Knorr (Exciter ring 80-teeth)</b>	<b>ABS Grau-Girling MGX-2 (Exciter ring 45-teeth) 1986 - 1993</b>
	X = see Fig.	X = 77 X = 77 X = 81 X = 81 X = 93	03.310.08.27.0 Ø 145/152/163x17 03.310.08.43.0 Ø 145/152/163x14.5 03.310.08.18.0 Ø 152/170x15 05.310.08.44.1 <sup>1)</sup> Ø 150/176/180x19.5 03.310.08.24.1 <sup>1)</sup> Ø 170/176/194x17.5/3xM6
561	Grub screw	02.5018.09.08 M 6 x 15 / 914-45H	02.5018.09.08 M 6 x 15 / 914-45H
562	Hexagon nut	02.5202.10.82 M 6 / 934	02.5202.10.82 M 6 / 934
564	Clip (for drive pin) Clip (Clip for welded bolt)	02.0326.32.00 1 x 6 / 72571-St 02.3507.32.00	02.0326.32.00 1 x 6 / 72571-St 02.3507.32.00
565	Drive pin	02.6006.25.40 Ø 4 x 10 / 1476-St	02.6006.25.40 Ø 4 x 10 / 1476-St
570	Sensor	02.3317.05.00	02.3317.03.00 Grau-Girling MGX-2
571	Bush	02.0316.59.00	-
575	Cylinder head screw	-	02.5015.02.80 M 5 x 12 / 912
577	Spring washer	-	02.5601.05.90 A 5 / 128
585	Support	03.189.07.72.0	-
586	Support	02.1421.11.00	-
587	Serrated lock washer	02.5414.11.90 A 10.5 / 6798	-

<sup>1)</sup> Exciter rings with mounting bore Ø 176 can also be bolted to hubs with exciter ring seat Ø 175.

## 6.2 ABS retrofit part sets

ABS retrofit part sets for one axle consisting of exciter rings, sensors, sensor retainers, fastening components and mounting drawings.		<b>ABS System</b>	
		Wabco / Bosch also for: Grau DGX / M Grau MGX 100 Knorr	
<b>H.. / R..</b>			
Axle type		Bremse	BPW Code no.
<b>H.. 6500 - 9000</b>	<input type="checkbox"/> 120 (up to production week 31/87) Sensor bracket welded on	SN 42..-2	05.801.72.17.0
<b>H.. 6500 - 9000</b>	<input type="checkbox"/> 120 (from production week 32/87) Sensor bracket screwed on	SN 42..-2/ SN 42.. BPW 95	05.801.72.01.0
<b>H.. 8000 - 9000 ECOPlus</b>	<input type="checkbox"/> 120 Sensor bracket screwed on	SN 42.. BPW 95	05.801.74.03.0
<b>R.. 6510 - 9010</b>	<input type="radio"/> 127 Sensor bracket screwed on	SN 42..-2/ SN 42.. BPW 95	05.801.73.29.0
<b>H.. 9200</b>	<input type="checkbox"/> 150 Sensor bracket welded on	SN 42..-2	05.801.72.03.0
<b>H.. 10000 - 12000</b>	<input type="checkbox"/> 150 (up to production week 12/88) <input type="checkbox"/> 150 x 16 (up to production week 03/89) Sensor bracket welded on	SN 42..-2	05.801.72.19.0
<b>H.. 10000 - 12000</b>	<input type="checkbox"/> 150 (from production week 13/88) <input type="checkbox"/> 150 x 16 (from production week 04/89) Sensor bracket screwed on	SN 42..-2 SN 42.. BPW 95	05.801.72.07.0
<b>H.. 9100 / 10100</b>	<input type="checkbox"/> 150 Brake position 16° Sensor bracket screwed on	SN 42..-2 SN 42.. BPW 95	05.801.72.59.1
<b>H.. 13000 - 14000</b>	<input type="checkbox"/> 150 Sensor bracket screwed on	SN 42..-2 SN 42.. BPW 95	05.801.73.25.0



## ABS retrofit part sets 6.2

ABS retrofit part sets for one axle consisting of exciter rings, sensors, sensor retainers, fastening components and mounting drawings.			ABS System
			Wabco / Bosch also for: Grau DGX / M Grau MGX 100 Knorr
KH.. / KR..			
Axle type		Bremse	BPW Code no.
KH.. 6500 - 9000	<input type="checkbox"/> 120 Sensor bracket screwed on	SN 36..	05.801.72.29.0
KH.. 6500 - 9000	<input type="checkbox"/> 120 Sensor bracket screwed on	SN 36.. BPW 95	05.801.72.29.0
KH.. 8000 - 9000 ECOPlus	<input type="checkbox"/> 120 Sensor bracket screwed on	SN 36.. BPW 95	05.801.74.13.0
KH.. 8010/3	<input type="checkbox"/> 120 Sensor bracket screwed on	SN 36.. BPW 95	05.801.73.72.0
KH.. 8010/3 ECOPlus	<input type="checkbox"/> 120 Sensor bracket screwed on	SN 36.. BPW 95	05.801.74.12.0
KR 9008 / 9010	<input type="radio"/> 127	SN 36..	05.801.72.53.0
KH.. 10008	<input type="checkbox"/> 120 (up to production week 52/88) Sensor bracket welded on	SN 36..	05.801.72.31.0
KH.. 10008	<input type="checkbox"/> 120 (from production week 1/89) Sensor bracket screwed on	SN 36..	05.801.72.35.0
KR.. 10008	<input type="radio"/> 127	SN 36..	05.801.72.51.0
KH.. 10010	<input type="checkbox"/> 120 (up to production week 52/88) Sensor bracket welded on	SN 36..	05.801.72.33.0
KH.. 10010	<input type="checkbox"/> 120 (from production week 1/89) Sensor bracket screwed on	SN 36..	05.801.72.37.0
KH.. 10010 - 12010	<input type="checkbox"/> 120 Sensor bracket screwed on	SN 36.. BPW 95	05.801.73.67.0
KR.. 10010	<input type="radio"/> 127	SN 36..	05.801.72.61.0

ABS retrofit part sets for one axle consisting of exciter rings, sensors, sensor retainers, fastening components and mounting drawings.			ABS System
			Wabco / Bosch also for: Grau DGX / M Grau MGX 100 Knorr
NH.. / NR..			
Axle type		Brake	BPW Code no.
NR.. 6006	<input type="radio"/> 127	SN 30..-1	05.801.72.49.0
NR.. 6008 / 6010	<input type="radio"/> 127	SN 30..-1	05.801.72.47.0
NH.. 6000 / 6400	<input type="checkbox"/> 120	SN 3015 BPW 95	05.801.73.51.0
NR.. 6400	<input type="radio"/> 127	SN 30..-1	05.801.72.92.0
NR.. 7006	<input type="radio"/> 127	SN 30..-1	05.801.72.63.0
NR.. 8008 / 8010	<input type="radio"/> 127	SN 30..-1	05.801.72.45.0
NR.. 8010	<input type="radio"/> 127, Brake drums 260 mm	SN 30..-1	05.801.72.70.0
NR.. 9010	<input type="radio"/> 127 Sensor bracket welded on	SN 30.. Quick-release brake shoes	05.801.73.01.0
NH.. 8010 / 9010	<input type="checkbox"/> 120 Sensor bracket screwed on	SN 3020 BPW 95	05.801.73.53.0
NR.. 10010	<input type="radio"/> 127, Brake drums 260 mm	SN 30..-1	05.801.72.72.0
NR.. 10010	<input type="radio"/> 127	SN 30.. Quick-release brake shoes	05.801.72.98.0
NH.. 10010 - 12010	<input type="checkbox"/> 120	SN 3020 BPW 95	05.801.73.55.0
NR.. 13010	<input type="radio"/> 127	SN 30..-1	05.801.72.57.0

7 TRILEX

Conventional hub bearing system

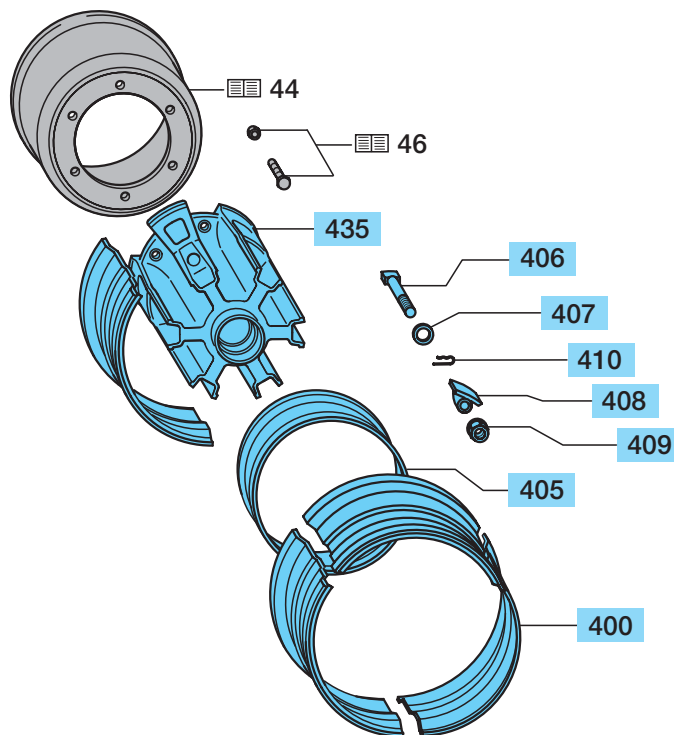

Item	Designation (Remark)	BPW Code no.	Dimension
		<b>6.5 - 9 t</b> --.06. / 08.----	<b>10 - 12 t</b> --.10.----
435	TRILEX wheel		
	HI.. 20" / 22.5"	02.3910.31.16 <sup>1)</sup> BSI / GF	02.3910.49.38 <sup>3)</sup> BSI / GF
	HIZ.. 20" / 22.5"	02.3910.31.24 <sup>2)</sup> BSI / GF	03.328.76.48.0 <sup>2)</sup> BPW
	HIZ.. 24"	02.3910.31.26 <sup>2)</sup> BSI / GF	03.328.76.47.0 <sup>2)</sup> BPW
		<b>13 - 14 t (14000-1)</b> ---.14.----	<b>16 - 18 t</b> ---.16.----
	HIZ.. 20" / 22.5"	02.3910.63.02 <sup>1)</sup> BSI / GF	02.3910.82.01 <sup>1)</sup> BSI / GF
	HIZ.. 20" / 22.5"	02.328.83.04.0 <sup>2)</sup> BPW	-
	HIZ.. 24"	03.328.83.06.0 <sup>3)</sup> BPW	02.3910.82.03 <sup>1)</sup> BSI / GF
	HIZ.. 24"	-	03.328.86.05.0 <sup>2)</sup> BPW, small spoke
	HIZ.. 24"	-	03.328.86.06.0 <sup>2)</sup> BPW, wide spoke

<sup>1)</sup> for TRILEX screws M 18 x 2

<sup>2)</sup> for TRILEX screws M 20 x 2

<sup>3)</sup> for rim 7.5 to 8.5 - 20" and Unilex/Tublex  
TRILEX screws M 20 x 2

H.. / R..					
Item	Designation (Remark)	BPW Code no.	Dimension	BSI or GF - No.	
400	Rim	02.1034.06.00	7.0 - 20	650 - 410 - 318	
		02.1034.05.00	7.5 - 20	650 - 410 - 323	
		02.1034.04.00	8.0 - 20	650 - 410 - 327	
		02.1034.02.00	8.5 - 20	650 - 410 - 355	
		02.1034.03.00	10.0 - 20	650 - 410 - 373	
		02.1034.13.00	10.00V - 20	650 - 311 - 235	
		02.1034.29.00	9.00x22.5	650 - 511 - 913	
		02.1034.18.00	14.00x22.5	650 - 511 - 450	
		02.1034.01.00	8.5 - 24	650 - 410 - 357	
		02.1034.07.00	10.0 - 24	650 - 410 - 374	
405	Spacer	02.5671.54.00	124 - 20	656 - 042 - 044	
		02.5671.53.00	130 - 20	656 - 042 - 046	
		02.5671.61.00	139 - 20	656 - 042 - 049	
		02.5671.58.00	177 - 20	656 - 062 - 059	
		02.5671.52.00	130 - 24	656 - 042 - 446	
		02.5671.56.00	139 - 24	656 - 042 - 449	
		02.5671.59.00	147 - 24	656 - 042 - 451	
		02.5671.63.00	177 - 24	656 - 062 - 459	
406	Screw	02.5070.25.00	M 18x2x95	659 - 112 - 454	
		02.5070.21.00	M 18x2x110	659 - 112 - 455	
		02.5070.22.00	M 18x2x125	659 - 112 - 456	
		02.5070.23.00	M 18x2x140	659 - 112 - 457	
		02.5070.89.00	M 20x2x57	659 - 112 - 616	
		02.5070.86.00	M 20x2x100	659 - 112 - 611	
		02.5070.32.00	M 20x2x115	659 - 112 - 612	
		02.5070.87.00	M 20x2x130	659 - 112 - 613	
		02.5070.88.00	M 20x2x145	659 - 112 - 614	
407	Washer	02.5450.22.00	Ø 20.5/34x2.5	659 - 120 - 228	
408	Clamping plate	<b>HIZ..</b> 1	02.1816.14.00	Ø 21 20"/24"	659 - 002 - 171
		<b>HI..</b> 2	02.1816.18.00	Ø 21 20"/24"	659 - 002 - 193
		<b>HI..</b> Unilex/Tublex E 3	02.1816.19.00	Ø 21 20"/22.5"	659 - 002 - 199
409	Nut	02.5270.03.00	M 18x2/SW27	659 - 115 - 300	
		02.5270.04.00	M 20x2/SW27	659 - 115 - 304	
410	Clip	02.1818.10.00		659 - 130 - 017	

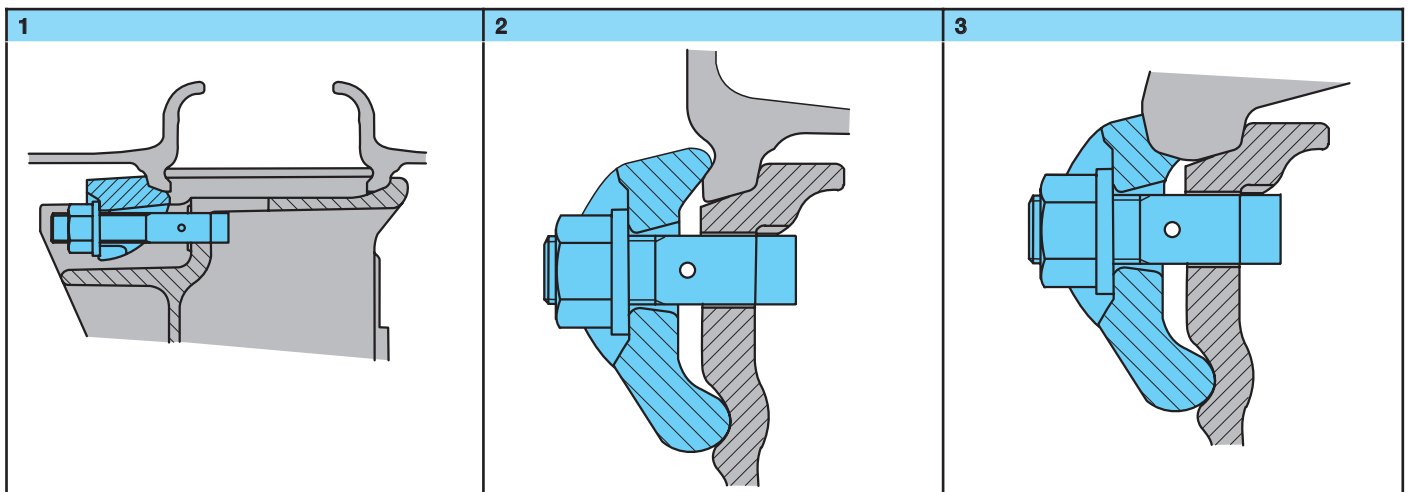

## 8 Wheel studs

H

### General

K

#### BPW wheel studs

The wheel nave (or wheel disc) connects the rim to the wheel hub. It must absorb the vertical, lateral and longitudinal forces which arise and transmit them to the wheel hub via the wheel studs (wheel bolts).

N

BPW axles are suitable for wheels with either stud or hub centring. BPW axles are supplied with either collar studs or spiral studs, depending on the axle type and axle load.

Spiral studs are easy to maintain and connect the brake drum to the hub using a pressfit. As a result, there is no need for internal nuts.

The hub bore is not damaged even after several removal/installation operations (in contrast to the situation with splined studs) and the holding forces for the wheel studs remain constant. A collar stud also allows repeated removal and installation, although it is secured using an internal nut.

The prescribed BPW tightening torques for wheel attachment are listed in the current BPW maintenance instructions and must be observed.

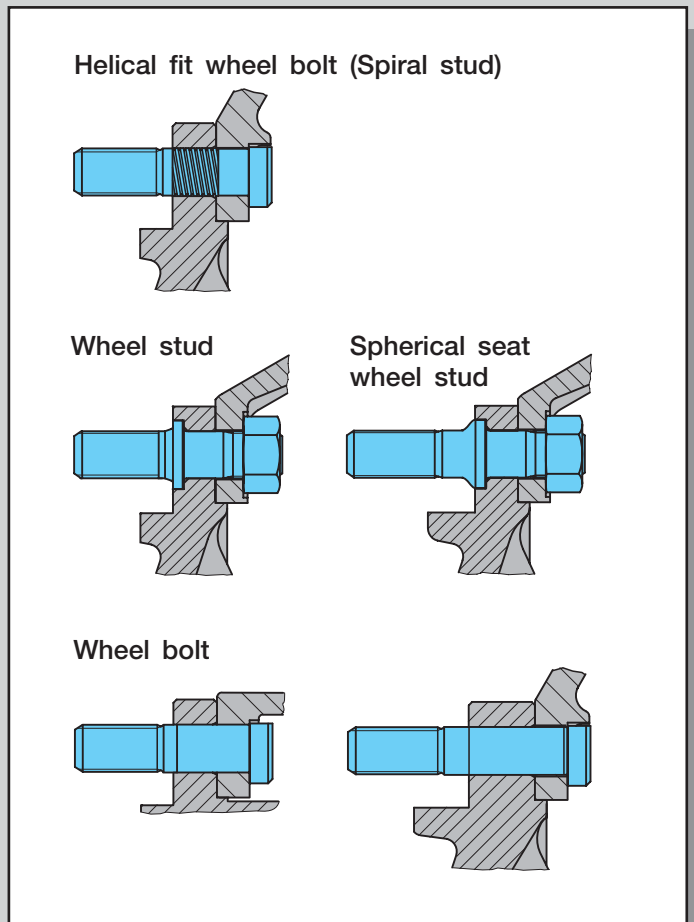

### Stud alignment

In stud centring, the wheel nave (with countersunk stud holes) is centred using wheel studs with (spring) centring rings.

In the case of spherical studs, the wheel nave is directly centred on the collar of the wheel studs.

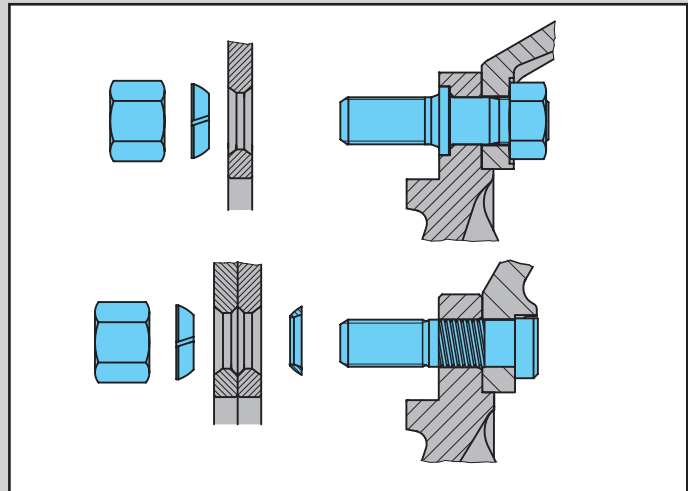

### Spigot alignment

In hub centring, the wheel nave is centred using a centring spigot or ring surfaces on the wheel hub.

In the case of 8-hole disc wheels with countersunk stud holes and 10-hole disc wheels, a centring bush is mounted on 2 opposite wheel studs for each hub.

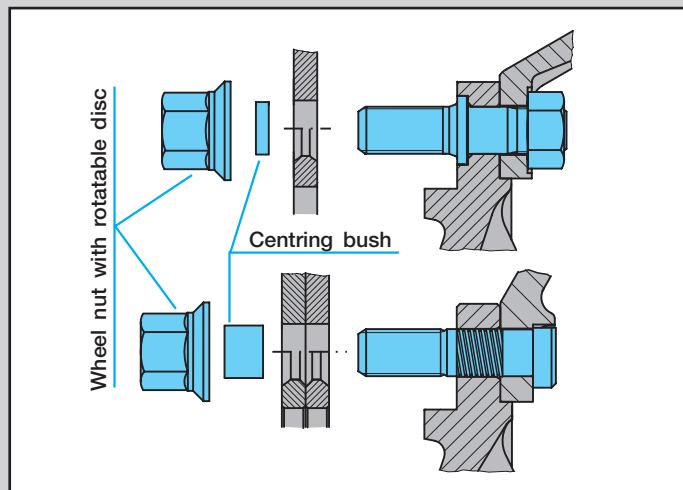

### Alloy wheels

In the case of aluminium wheels, the wheel nave is centred using a centring cam or ring surfaces on the wheel hub.

The flange thickness of aluminium wheels is greater than that of steel wheels, so it is necessary to check whether the vehicle is equipped for having aluminium wheels fitted (with stud hole  $\text{Ø } 26$ ), i.e. whether there is a sufficient hub shoulder and longer wheel studs).

If not, aluminium wheels with stud hole  $\text{Ø } 32$  can be used in conjunction with shaft nuts without replacing the hub or the wheel studs.

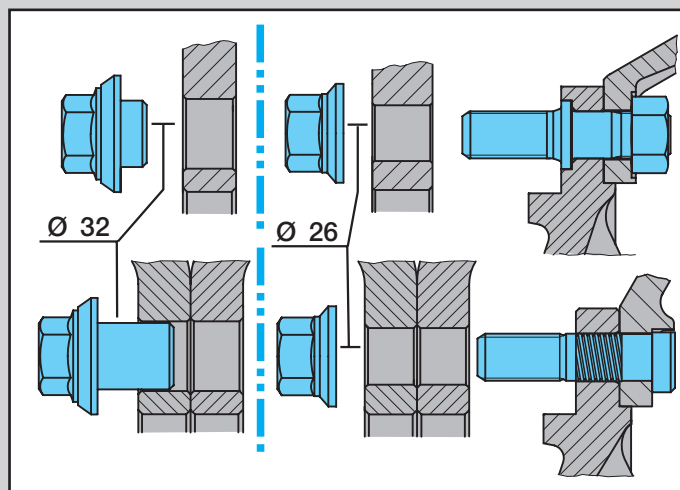

8.1 Wheel studs, single wheels

Single wheels

Thread ( D ) Wheel stud	Hub		Wheel type						Wheel nut type				Fig.	item 470 Wheel stud assembly cpl. 09.806. (item 472-474, 477-479)	Dimension Wheel stud L / L1 / L2	item 472 Wheel stud 03.296.	item 474 Rear nut 03.260.
	Steel hub	Alloy hub	Steel wheel with offset	Steel wheel without offset	Alloy wheel Ø 26 with offset	Alloy wheel Ø 26 without offset	Alloy wheel Ø 32 with offset	Alloy wheel Ø 32 without offset	Stud alignment	Spigot alignment	Standard SW 24	Standard SW 27					

M 18 x 1.5

Wheel stud	•			•					•		•					2 A	21.14.0	87/36/47	21.11.0	03.05.0
	•			•					•		•					~2 B	21.18.0	89/41/44	21.14.0	03.05.0

M 20 x 1.5

Wheel stud	•			•					•		•					2 B	22.05.0	94/43/47	22.04.0	03.05.0
	•			•					•		•					2 D	22.18.0	94/43/47	22.04.0	03.05.0

M 22 x 1.5

Wheel stud	•		•						•							1 A	23.23.0	84/46/33	23.14.0	04.06.0
	•		•						•							1 C	23.17.0	84/46/33	23.14.0	04.06.0
	•		•						•							~1 C	23.36.0	84/46/33	23.14.0	04.06.0
	•			•					•							2 A	23.27.0	100/46/49	23.15.1	04.06.0
	•			•					•							2 C	23.18.0	100/46/49	23.15.1	04.06.0
	•			•					•							~2 C	23.37.0	100/45/49	23.15.1	04.06.0
	•				•											1 E	23.56.0	101/60/36	23.16.0	04.06.0
	•					•										2 E	23.41.0	114/60/49	23.17.0	04.06.0
	•						•									~2 E	23.51.0	114/60/49	23.17.0	04.06.0
	•							•								1 F	23.52.0	84/46/33	23.14.0	04.06.0
•								•							2 F	23.43.0	100/46/49	23.15.1	04.06.0	
Helical fit wheel bolt	•			•					•							3 A	33.57.0	89/50	33.14.1	-
	•			•					•							3 C	33.11.0	89/50	33.14.1	-
	•			•					•							~3 C	33.61.0	89/50	33.14.1	-
	•					•										3 E	33.68.0	97/62	33.12.1	-
	•					•										~3 E	33.63.0	103/58	33.13.1	-
	•						•									3 F	33.64.0	89/50	33.14.1	-
	•		•						•							3 A	33.65.0	103/58	33.13.1	-
	•		•						•							3 C	33.59.0	103/58	33.13.1	-
	•		•						•							~3 C	33.66.0	103/58	33.13.1	-
	•					•										3 E	33.59.0	103/58	33.13.1	-
•					•										~3 E	33.66.0	103/58	33.13.1	-	
•						•									3 F	33.60.0	103/58	33.13.1	-	

M 22 x 2

Spherical seat wheel stud	•		•						•							1 A	23.01.0	84/46/33	23.02.0	04.06.0
	•			•					•							2 A	23.02.0	100/46/49	23.05.0	04.06.0
	•			•					•							~2 A	23.25.0	100/46/49	23.05.0	04.06.0

1) Bush not included in wheel stud assembly 09.806..... SW = Spanner width 03.260.03.05.0 = M 20 x 1.5  
 Fitted to two oppositely mounted wheel studs per hub with 8-hole disc wheels with countersunk stud holes and 10-hole disc wheels. 03.260.04.06.0 = M 22 x 2

# Wheel studs, single wheels 8.1

item 476	item 478	item 479
Bush 1) 03.112.	Spring washer 02.5615.	Wheel nut
-	18.94	02.5213.12.10
-	-	02.5219.18.10
-	20.90	02.5213.14.10
-	-	02.5219.20.10
-	22.90	03.260.04.12.0
00.43.0	-	05.260.54.10.0
00.43.0	-	05.260.54.19.0
-	22.90	03.260.04.12.0
00.43.0	-	05.260.54.10.0
00.43.0	-	05.260.54.19.0
-	-	05.260.54.10.0
-	-	05.260.54.10.0
-	-	05.260.54.19.0
-	-	05.260.54.21.1
-	-	05.260.54.21.1
-	22.90.0	03.260.04.12.0
00.43.0	-	05.260.54.10.0
00.43.0	-	05.260.54.19.0
-	-	05.260.54.10.0
-	-	05.260.54.19.0
-	-	05.260.54.21.1
-	22.90	03.260.04.12.0
00.43.0	-	05.260.54.10.0
00.43.0	-	05.260.54.19.0
-	-	05.260.54.10.0
-	-	05.260.54.19.0
-	-	05.260.54.21.1
-	22.90	03.260.04.01.0
-	22.90	03.260.04.01.0
-	22.90	05.260.14.05.0

Wheel stud		Helical fit wheel bolt											
<b>Wheel stud</b> <b>Wheels with offset</b> 1 	<b>Wheel stud</b> <b>Wheels without offset</b> 2 	<b>Helical fit wheel bolt</b> 3 <p>Steel hub x = 20 Alloy hub x = 30</p>											
<b>Steel wheels</b> <b>Stud alignment</b> A 		<b>B</b> <b>Tightening torques for wheel nuts item 479</b> <table border="1"> <thead> <tr> <th>Thread</th> <th>Stud alignment</th> </tr> </thead> <tbody> <tr> <td>M 18 x 1.5</td> <td>270 Nm (255-285)</td> </tr> <tr> <td>M 20 x 1.5</td> <td>350 Nm (330-370)</td> </tr> <tr> <td>M 22 x 1.5</td> <td>475 Nm (450-500)</td> </tr> <tr> <td>M 22 x 2</td> <td>430 Nm (410-450)</td> </tr> </tbody> </table>		Thread	Stud alignment	M 18 x 1.5	270 Nm (255-285)	M 20 x 1.5	350 Nm (330-370)	M 22 x 1.5	475 Nm (450-500)	M 22 x 2	430 Nm (410-450)
Thread	Stud alignment												
M 18 x 1.5	270 Nm (255-285)												
M 20 x 1.5	350 Nm (330-370)												
M 22 x 1.5	475 Nm (450-500)												
M 22 x 2	430 Nm (410-450)												
<b>C</b> <b>Steel wheels</b> <b>Spigot alignment</b> 		<b>D</b> <b>Tightening torques for wheel nuts item 479</b> <table border="1"> <thead> <tr> <th>Thread</th> <th>Spigot alignment</th> </tr> </thead> <tbody> <tr> <td>M 18 x 1.5</td> <td>320 Nm (305-335)</td> </tr> <tr> <td>M 20 x 1.5</td> <td>450 Nm (425-475)</td> </tr> <tr> <td>M 22 x 1.5</td> <td>600 Nm (570-630)</td> </tr> </tbody> </table>		Thread	Spigot alignment	M 18 x 1.5	320 Nm (305-335)	M 20 x 1.5	450 Nm (425-475)	M 22 x 1.5	600 Nm (570-630)		
Thread	Spigot alignment												
M 18 x 1.5	320 Nm (305-335)												
M 20 x 1.5	450 Nm (425-475)												
M 22 x 1.5	600 Nm (570-630)												
<b>E</b> <b>Alloy wheels Ø 26</b> 	<b>F</b> <b>Alloy wheels Ø 32</b> 	<b>Tightening torques for wheel nuts item 479</b> <table border="1"> <thead> <tr> <th>Thread</th> <th>Alloy wheels</th> </tr> </thead> <tbody> <tr> <td>M 22 x 1.5</td> <td>600 Nm (570-630)</td> </tr> </tbody> </table>		Thread	Alloy wheels	M 22 x 1.5	600 Nm (570-630)						
Thread	Alloy wheels												
M 22 x 1.5	600 Nm (570-630)												
		<b>Tightening torques for rear nuts item 474</b> <table border="1"> <thead> <tr> <th>Thread</th> <th></th> </tr> </thead> <tbody> <tr> <td>M 20 x 1.5</td> <td>495 Nm (470-520)</td> </tr> <tr> <td>M 22 x 2</td> <td>640 Nm (610-670)</td> </tr> </tbody> </table>		Thread		M 20 x 1.5	495 Nm (470-520)	M 22 x 2	640 Nm (610-670)				
Thread													
M 20 x 1.5	495 Nm (470-520)												
M 22 x 2	640 Nm (610-670)												

H  
K  
N

## 8.2 Wheel studs, twin wheels

### Twin wheels

Thread ( D )	Hub		Wheel type				Wheel nut type					Fig.	item 470 Wheel stud assembly cpl. 09.806. (item 472-474, 477-479)	Dimension Wheel stud L / L1 / L2	item 472	item 474	item 476	
	Steel hub	Alloy hub	Steel wheels	Alloy wheels Ø 26	Alloy wheels Ø 32	Stud alignment	Spigot alignment	Standard SW 24	Standard SW 27	Standard SW 32	Cap nutSW 32							Cap nutSW 33
Wheel stud																		

### M 18 x 1.5

Wheel stud	•		•			•		•					1 C	21.19.0	102/51/47	21.15.0	03.05.0	-
Spherical seat wheel stud	•		•			•		•					2 B	11.11.0	97/46/47	11.10.0	03.05.0	-
Wheel bolt	•		•			•		•					4 A	31.08.0	81/50	31.03.0	-	-
	•		•			•		•					4 D	31.09.0	81/ 50	31.03.0	-	-

### M 20 x 1.5

Wheel stud	•		•			•		•					1 A	12.03.0	101/48/47	12.04.0	03.05.0	-
Wheel bolt	•		•			•		•					4 A	32.07.0	89/56	32.03.0	-	-
	•		•			•		•					4 D	32.06.0	89/56	32.03.0	-	-

### M 22 x 1.5

Wheel stud	•		•			•		•					1 A	23.28.0	114/60/49	23.17.0	04.06.0	-
	•		•			•		•					1 C	23.22.0	114/60/49	23.17.0	04.06.0	00.42.0
	•		•			•		•					~1 C	23.29.0	114/60/49	23.17.0	04.06.0	00.42.0
	•			•				•					1 E	23.50.0	136/82/49	23.24.0	04.06.0	-
	•			•					•				~1 E	23.49.0	136/82/49	23.24.0	04.06.0	-
	•				•								1 F	23.44.0	136/82/49	23.24.0	04.06.0	-
Helical fit wheel bolt	•		•			•		•					3 A	33.67.0	97/62	33.12.1	-	-
	•		•			•		•					3 C	33.68.0	97/62	33.12.1	-	00.42.0
	•		•			•		•					~3 C	33.69.0	97/62	33.12.1	-	00.42.0
Wheel bolt	•		•			•		•					5 A	33.06.0	92/70	33.08.0	-	-
	•		•			•		•					5 C	33.07.0	92/70	33.08.0	-	00.42.0
	•		•			•		•					~5 C	33.09.0	92/70	33.08.0	-	00.42.0
		•	•			•		•					6 A	33.70.0	128/84	33.09.0	-	-
		•	•			•		•					6 C	33.71.0	128/84	33.09.0	-	00.42.0
		•	•			•		•					~6 C	33.72.0	128/84	33.09.0	-	00.42.0
		•	•					•					6 D	33.73.0	128/84	33.09.0	-	-
		•	•						•				~6 D	33.72.0	128/84	33.09.0	-	-
		•		•									6 F	33.74.0	128/84	33.09.0	-	-

### M 22 x 2

Spherical seat wheel stud	•		•			•		•					2 B	13.02.0	111/57/49	13.09.0	04.06.0	-
	•		•			•				•			~2 B	13.09.0	111/57/49	13.09.0	04.06.0	-
	•		•							•			~2 B	13.23.0	111/57/49	13.09.0	04.06.0	-

- 1) Bush not included in wheel stud assembly 09.806..... SW = Spanner width 03.260.03.05.0 = M 20 x 1.5  
 Fitted to two oppositely mounted wheel studs per hub with 8-hole disc wheels with countersunk stud holes and 10-hole disc wheels. 03.260.04.06.0 = M 22 x 2
- 2) Centring ring with spherical wheel stud and twin wheels.



## Wheel studs, twin wheels 8.2

item 477	item 478	item 479
Centring ring 2) 03.310.	Spring washer 02.5615.	Wheel nut
-	-	05.260.53.07.0
-	18.94	02.5213.12.14
10.27.0	18.94	02.5213.12.14
-	-	02.5219.18.10
-	20.90	02.5213.14.10
10.02.0	20.90	02.5213.14.10
-	-	02.5219.20.10
10.13.0	22.90	03.260.04.12.0
-	-	05.260.54.10.0
-	-	05.260.54.19.0
-	-	05.260.54.10.0
-	-	05.260.54.19.0
-	-	05.260.54.14.1
10.13.0	22.90	03.260.04.12.0
-	-	05.260.54.10.0
-	-	05.260.54.19.0
10.13.0	22.90	03.260.04.12.0
-	-	05.260.54.10.0
-	-	05.260.54.19.0
-	-	05.260.54.19.0
-	-	05.260.54.14.1
-	22.90	03.260.04.01.0
-	22.90	05.260.14.03.0
-	22.90	05.260.14.05.0

Wheel stud	Spherical seat wheel stud	Helical fit wheel bolt	Wheel bolt										
<b>Wheel stud</b>	<b>1 Spherical seat wheel stud</b>	<b>2 Helical fit wheel bolt</b>	<b>3</b>										
<b>Wheel bolt</b>	<b>4 Wheel bolt NR..</b>	<b>5 Wheel bolt, Alloy hub</b>	<b>6</b>										
<b>Steel wheels Stud alignment</b>	<b>A</b>	<b>B</b>	<b>Tightening torques for wheel nuts item 479</b>										
			<table border="1"> <thead> <tr> <th>Thread</th> <th>Stud alignment</th> </tr> </thead> <tbody> <tr> <td>M 18 x 1.5</td> <td>270 Nm (255-285)</td> </tr> <tr> <td>M 20 x 1.5</td> <td>350 Nm (330-370)</td> </tr> <tr> <td>M 22 x 1.5</td> <td>475 Nm (450-500)</td> </tr> <tr> <td>M 22 x 2</td> <td>430 Nm (410-450)</td> </tr> </tbody> </table>	Thread	Stud alignment	M 18 x 1.5	270 Nm (255-285)	M 20 x 1.5	350 Nm (330-370)	M 22 x 1.5	475 Nm (450-500)	M 22 x 2	430 Nm (410-450)
Thread	Stud alignment												
M 18 x 1.5	270 Nm (255-285)												
M 20 x 1.5	350 Nm (330-370)												
M 22 x 1.5	475 Nm (450-500)												
M 22 x 2	430 Nm (410-450)												
<b>Steel wheels Spigot alignment</b>	<b>C</b>	<b>D</b>	<b>Tightening torques for wheel nuts item 479</b>										
			<table border="1"> <thead> <tr> <th>Thread</th> <th>Spigot alignment</th> </tr> </thead> <tbody> <tr> <td>M 18 x 1.5</td> <td>320 Nm (305-335)</td> </tr> <tr> <td>M 20 x 1.5</td> <td>450 Nm (425-475)</td> </tr> <tr> <td>M 22 x 1.5</td> <td>600 Nm (570-630)</td> </tr> </tbody> </table>	Thread	Spigot alignment	M 18 x 1.5	320 Nm (305-335)	M 20 x 1.5	450 Nm (425-475)	M 22 x 1.5	600 Nm (570-630)		
Thread	Spigot alignment												
M 18 x 1.5	320 Nm (305-335)												
M 20 x 1.5	450 Nm (425-475)												
M 22 x 1.5	600 Nm (570-630)												
<b>Alloy wheels Ø 26</b>	<b>E</b>	<b>F</b>	<b>Tightening torques for wheel nuts item 479</b>										
			<table border="1"> <thead> <tr> <th>Thread</th> <th>Alloy wheels</th> </tr> </thead> <tbody> <tr> <td>M 22 x 1.5</td> <td>600 Nm (570-630)</td> </tr> </tbody> </table>	Thread	Alloy wheels	M 22 x 1.5	600 Nm (570-630)						
Thread	Alloy wheels												
M 22 x 1.5	600 Nm (570-630)												
			<b>Tightening torques for rear nuts item 474</b>										
			<table border="1"> <thead> <tr> <th>Thread</th> <th></th> </tr> </thead> <tbody> <tr> <td>M 20 x 1.5</td> <td>495 Nm (470-520)</td> </tr> <tr> <td>M 22 x 2</td> <td>640 Nm (610-670)</td> </tr> </tbody> </table>	Thread		M 20 x 1.5	495 Nm (470-520)	M 22 x 2	640 Nm (610-670)				
Thread													
M 20 x 1.5	495 Nm (470-520)												
M 22 x 2	640 Nm (610-670)												

H  
K  
N

9 Hub caps with integrated Hubodometer

Axle load	Axle series	Axle type	Hub cap thread	for tyre e.g.	Developed area	Hub cap with integrated Hubodometer BPW Code no.	
6.5 - 9 t	H.. / R..	H.. / R..	M 115 x 2	365/80 R 20	3280 - 3310	05.212.23.27.0	
				385/65 R 22.5	3240 - 3260	05.212.23.35.0	
				10.00 R 20	3175 - 3220	05.212.23.34.0	
				11.00 R 22.5			
		H.. ECO H.. ECO MAXX	M 125 x 2	365/ 80 R 20	3280 - 3310	05.212.24.56.0	
				385/65 R 22.5	3240 - 3260	05.212.24.29.0	
				425/65 R 22.5	3410 - 3470	05.212.24.54.0	
				10.00 R 20	3175 - 3220	05.212.24.49.0	
				11.00 R 22.5			
				315/70 R 22.5	3015 - 3134	05.212.24.51.0	
				275/70 R 22.5	2915	05.212.24.52.0	
				255/70 R 22.5	2830 - 2860	05.212.24.53.0	
		H.. ECOPlus	M 136 x 2.5	255/70 R 22.5	2830 - 2860	05.212.25.41.0	
				275/70 R 22.5	2915	05.212.25.42.0	
				315/70 R 22.5	3015 - 3134	05.212.25.44.0	
				10.00 R 20	3175 - 3220	05.212.25.45.0	
				11.00 R 22.5			
				385/65 R 22.5	3240 - 3260	05.212.25.46.0	
	12.00 R 22.5			3280 - 3310	05.212.25.47.0		
	425/65 R 22.5			3410 - 3470	05.212.25.48.0		
	13.00 R 22.5						
	445/65 R 22.5			3505	05.212.25.49.0		
	KH.. / KR..	KH.. / KR..	M 115 x 2	265/70 R 19.5	2620 - 2650	05.212.23.29.0	
				KH.. ECO KH.. ECO MAXX	M 125 x 2	385/65 R 19.5	3015 - 3134
		425/55 R 19.5	2960			05.212.24.46.0	
		445/45 R 19.5	2790			05.212.24.50.0	
		265/70 R 19.5	2620 - 2650			05.212.24.34.0	
		245/70 R 19.5	2560			05.212.24.44.0	
KH.. ECOPlus		M 136 x 2.5	265/70 R 19.5			2620 - 2650	05.212.25.38.0
			285/70 R 19.5	2712 - 2750	05.212.25.39.0		
			445/45 R 19.5	2790	05.212.25.40.0		
			425/55 R 19.5	2960	05.212.25.43.0		
			NH.. / NR..	M 115 x 2	215/75 R 17.5	2350	05.212.23.30.0
					235/75 R 17.5	2425	05.212.23.31.0
245/70 R 17.5		2464 - 2520			05.212.23.36.0		
NH.. ECO NH.. ECO MAXX		M 125 x 2			215/75 R 17.5	2350	05.212.24.35.0
	235/75 R 17.5				2425	05.212.24.58.0	
	245/70 R 17.5				2464 - 2520	05.212.24.36.0	
	205/65 R 17.5		2170	05.212.24.48.0			

 Hub caps for BPW ECO axles have internal thread.  
Further types upon request.

\* Modified cap thread from 09/00.  
Note thread size stamped on the cap!

## Hub caps with integrated Hubodometer

Axle load	Axle series	Axle type	Hub cap thread	for tyre e.g.	Developed area	Hub cap with integrated Hubodometer BPW Code no.		
<b>10 - 12 t</b>	<b>H.. / R..</b>	<b>H.. / R..</b>	<b>M 125 x 2</b>	425/65 R 22.5	3410 - 3470	05.212.24.32.0		
				445/65 R 22.5	3505	05.212.24.37.0		
				385/65 R 22.5	3240 - 3260	05.212.24.43.0		
				275/70 R 22.5	2915	05.212.24.38.0		
				10.00 R 20	3175 - 3220	05.212.24.31.0		
				11.00 R 22.5				
				12.00 R 22.5	3280 - 3310	05.212.24.39.0		
				13.00 R 22.5	3410 - 3470	05.212.24.32.0		
				<b>H.. ECO H.. ECO MAXX</b>	<b>M 135 x 2</b>	425/65 R 22.5	3410 - 3470	05.212.25.11.0
		445/65 R 22.5	3505			05.212.25.12.0		
		385/65 R 22.5	3240 - 3260			05.212.25.19.0		
		275/70 R 22.5	2915			05.212.25.13.0		
		10.00 R 20	3175 - 3220			05.212.25.10.0		
		11.00 R 22.5					05.212.25.10.5 Miles	
		12.00 R 22.5	3280 - 3310			05.212.25.14.0		
		13.00 R 22.5	3410 - 3470			05.212.25.11.0		
		255/70 R 22.5	2830 - 2860			05.212.25.24.0		
		315/70 R 22.5	3015 - 3134			05.212.25.25.0		
		<b>H.. ECO H.. ECO MAXX H.. ECOPlus</b>	<b>M 136 x 2.5</b>			255/70 R 22.5	2830 - 2860	05.212.25.41.0
				275/70 R 22.5	2915	05.212.25.42.0		
				315/70 R 22.5	3015 - 3134	05.212.25.44.0		
				10.00 R 20	3175 - 3220	05.212.25.45.0		
				11.00 R 22.5				
				385/65 R 22.5	3240 - 3260	05.212.25.46.0		
				12.00 R 22.5	3280 - 3310	05.212.25.47.0		
				425/65 R 22.5	3410 - 3470	05.212.25.48.0		
				13.00 R 22.5				
				445/65 R 22.5	3505	05.212.25.49.0		
		<b>KH.. / KR..</b>	<b>KH.. / KR..</b>	<b>M 125 x 2</b>	285/70 R 19.5	2712 - 2750	05.212.24.40.0	
					<b>KH.. ECO KH.. ECO MAXX</b>	<b>M 135 x 2</b>	285/70 R 19.5	2712 - 2750
	265/70 R 19.5						2620 - 2650	05.212.25.20.0
	245/70 R 19.5		2560	05.212.25.28.0				
	<b>KH.. ECO KH.. ECO MAXX KH.. ECOPlus</b>		<b>M 136 x 2.5</b>	265/70 R 19.5			2620 - 2650	05.212.25.38.0
				285/70 R 19.5	2712 - 2750	05.212.25.39.0		
				445/45 R 19.5	2790	05.212.25.40.0		
	425/55 R 19.5		2960	05.212.25.43.0				
	<b>NH.. / NR..</b>		<b>NH.. / NR..</b>	<b>M 125 x 2</b>	235/75 R 17.5	2425	05.212.24.41.0	
					245/70 R 17.5	2464 - 2520	05.212.24.57.0	
		9.50 R 17.5			2560	05.212.24.42.0		
		8.25 R 15						
		<b>NH.. ECO NH.. ECO MAXX</b>	<b>M 135 x 2</b>	245/75 R 17.5	2425	05.212.25.17.0*		
				235/70 R 17.5	2464 - 2520	05.212.25.51.0*		
9.50 R 17.5				2560	05.212.25.28.0*			
8.25 R 15								
<b>NH.. ECO NH.. ECO MAXX</b>		<b>M 136 x 2.5</b>	205/65 R 17.5	2170	05.212.25.34.0*			
			215/75 R 17.5	2350	05.212.25.35.0*			
			245/70 R 17.5	2425	05.212.25.36.0*			
			235/75 R 17.5					
9.50 R 17.5	2560	05.212.25.37.0*						
8.25 R 17.5								

H  
K  
N







BPW-ELHKN-05/1 e

