

OM 443

Mercedes-Benz Motorbaumuster

Mercedes-Benz Engine Model I Modèle de moteur Mercedes-Benz I Modelo

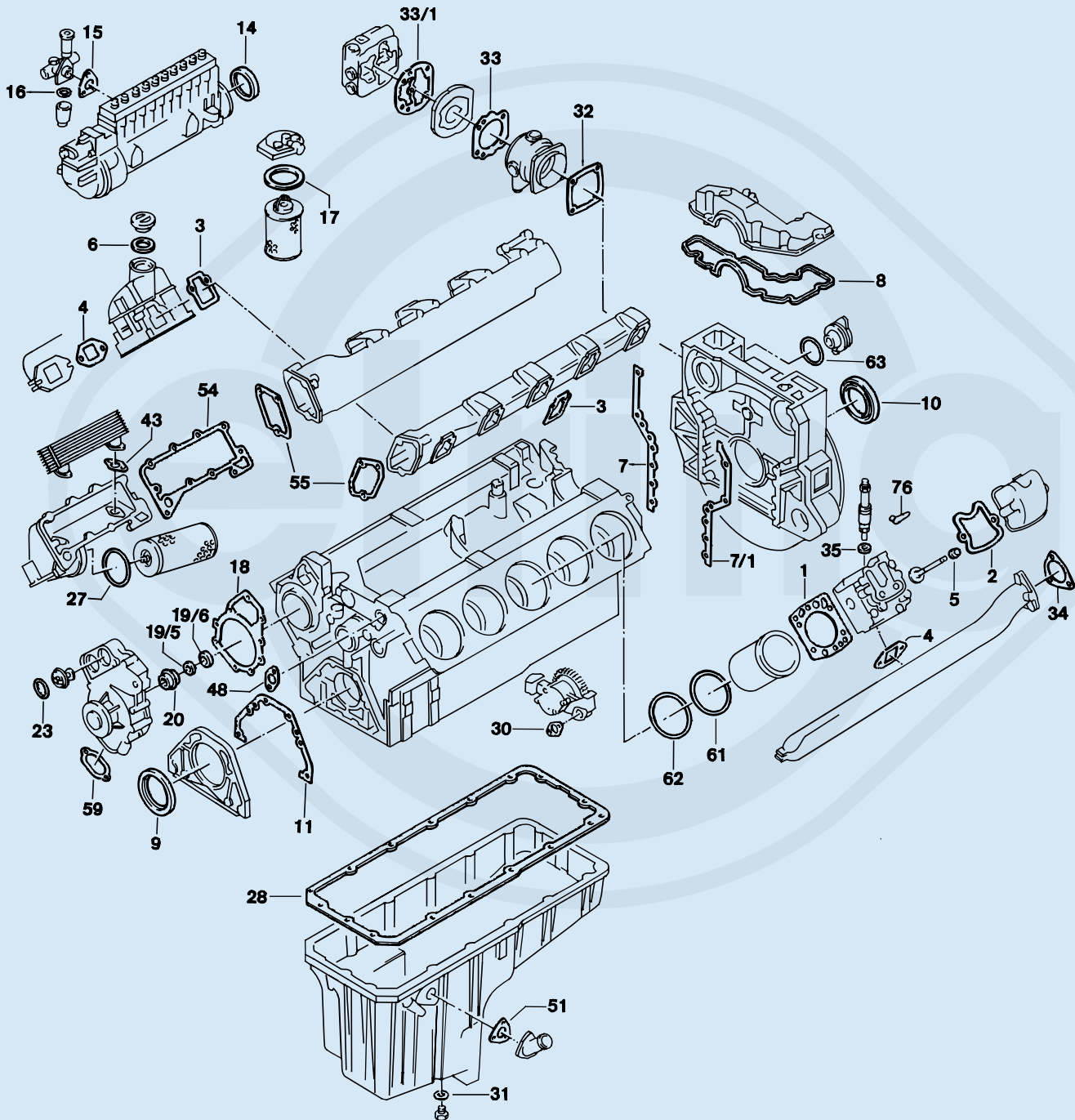

de motor Mercedes-Benz

Bild-Nr. Fig. No. No d'illustration Nº figura	Elring-Nr. Elring reference Référence Elring Referencia Elring	Stück Pieces Pièces Piezas	Teile-Nr. Part Number Référence Referencia	Bauart Material Abmessung Type Material Dimensions Type matériau dimension Tipo Material Medidas	Bemerkung Remarks Remarque Notas
ZLBS	827.568	10	–	–	incl. Tombak
ES	812.544	10	444 010 01 20	–	incl. 896.510
ES	812.545	10	444 010 01 20	–	incl. 412.180
ES	812.529	10	–	–	incl. 748.080
ES	413.810	10	–	–	incl. 896.510
CS *	812.587	10	423 010 06 08	–	–
WPS	812.617	1	422 200 09 01	–	–
SZ	812.552	1	423 010 48 33	–	Steuergehäuse timing case carter de distribution cubierta de la distribución
ZKS	820.091	10	–	–	–
1	748.110	10	422 016 07 20	143,5 Ø, 1,33 mm	Reparaturstufe repair size cote de réparation nivel de reparación
1	896.510	10	442 016 03 20	143,5 Ø, 1,25 mm	–
1	412.180	10	442 016 04 20	143,5 Ø, 1,25 mm	–
2	977.438	10	442 016 06 21	–	–
3	896.365	10	442 141 17 80	–	–
4	225.126	10	403 142 03 80	–	–
5	562.297	20	422 053 01 96	12x15,7/20x15 FPM	–
7	819.190	1	442 015 01 80	–	–
7/1	819.204	1	442 015 00 80	–	–
8	759.139	1	442 015 00 60	–	–
9	524.973	1	014 997 46 47	AW/BS RD FPM 105x130x12	–
10	562.920	1	013 997 14 47	AW/BS LD FPM 120x140x13	–
11	756.768	1	442 011 00 80	–	–
14	759.147	1	442 074 00 59	94,5x105,3x9 ACM PR	–
15	a.A.	1	001 074 22 80	–	–
16	716.200	1	000 997 00 40	28x36x2 NBR A	–
17	733.431	1	000 477 31 80	–	–
18	756.881	1	442 201 00 80	–	–
20	577.804	1	000 201 92 19	–	–
23	a.A.	2	024 997 28 48	–	–
27	780.103	1	008 997 70 45	–	–
28	775.347	1	443 014 00 22	–	mit Siebdruck with screen print avec sérigraphie con serigrafía
28	069.310	1	443 014 00 22	–	ohne Siebdruck without screen print sans sérigraphie sin serigrafía
30	759.309	1	917003 036003	–	–
31	031.046	1	007603 026109	26x34x2 CUW	–
32	452.130	1	442 131 27 80	–	–
33	773.204	1	442 131 06 80	–	→ Mot. 794006
33	490.710	1	442 131 28 80	–	Mot. 794007 →
33/1	137.452	1	442 131 29 80	–	→ Mot. 794006
33/1	137.440	1	442 131 22 80	–	Mot. 794007 →
34	778.060	2	442 492 00 80	–	–
35	106.909	10	346 017 01 60	1 mm	–
35	067.989	10	346 017 02 60	1,5 mm	–
43	759.295	2	917003 026003	–	–
51	756.784	1	442 018 00 80	–	–
54	765.732	1	442 188 05 80	–	–
55	756.830	2	442 141 07 80	–	–
59	768.391	1	442 201 04 80	–	–
61	001.860	10	025 997 84 48	140x143,8x1,9 FPM RD	–
61/1	703.214	10	442 011 00 59	Metall 0,15 mm	Tombak
61/1	863.020	10	–	Metall 0,25 mm	Tombak
61/1	896.455	10	442 011 02 59	Metall 0,50 mm	Tombak
62	001.880	20	025 997 85 48	144x151,6x3,8 FPM RD	–
63	a.A.	1	014 997 61 48	78x84x3 ACM RD	–