



DX Air Disc Brake Catalog Supplement

Table of Contents

	Page
DX195 Air Disc Brake	
Exploded View (Figure 1).....	2
Service Kits.....	3
Rotors (Figure 2).....	4
Hubs & Wheel Studs.....	4
 DX225 Air Disc Brake	
Exploded View (Figure 3).....	5
Service Kits.....	6
Rotor Identity (Figures 4 & 5).....	7
Rotors.....	8
Rotor Mounting Bolt.....	8
Hubs & Wheel Studs.....	8
Rear Hub Assemblies.....	8

Figure 1 - DX195 Caliper Assembly

DX-195-39 shown
DX-195-40 opposite

Note: Caliper assy. kit excludes
items 1,2,5,6,9,11,12

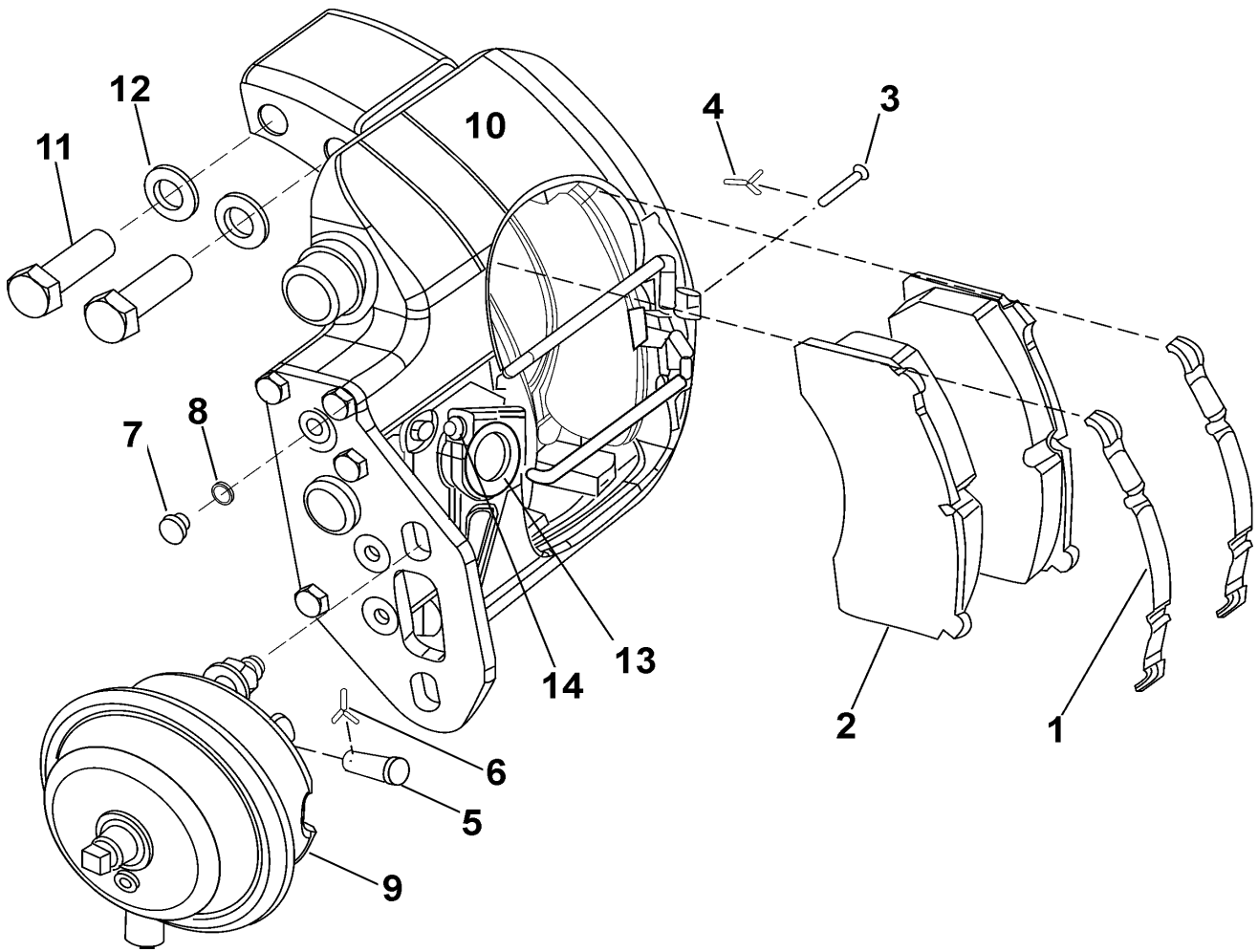

DX195 Caliper Service Kits – Figure 1

Kit Description	Aftermarket Kit	Item No.	OE Part Number	Qty. per Kit	Part Description
Pad Kit (R702)	KIT 195010	1	2258-C-1303	2	Spring
		2	A1-3222-T-2308	2	R702 Pad
		4	K-234Z	1	Cotter Pin
Stabilizing Bar Pin Kit	KIT 195012	3	19-X-1131	1	Retaining Pin
		4	K-234Z	1	Cotter Pin
Clevis Pin Kit	KIT 195013	5	43-X-1194	1	Clevis Pin
		6	K-234Z	1	Cotter Pin
Caliper Assembly Kit (Old # X1951011K)	DX-195-39	10	DX-195-39	1	Caliper
		3	19-X-1131	1	Retaining Pin
		4	K-234Z	1	Cotter Pin
Caliper Assembly Kit (Old # X1951012K)	DX-195-40	10	DX-195-40	1	Caliper
		3	19-X-1131	1	Retaining Pin
		4	K-234Z	1	Cotter Pin
Plug Kit	KIT 195005	7	1250-R-1006	1	Plug
		8	1229-V-4468	1	Washer
Air Chamber Kit Part numbers based on type of chamber used on the axle.	KIT 195006	9	V89-3276-P-16	1	Chamber - Type 16
		5	43-X-1194	1	Clevis Pin
		6	K-237Z	1	Cotter Pin
	KIT 195014	9	V87-3276-T-20	1	Chamber - Type 20
		5	43-X-1194	1	Clevis Pin
		6	K-237Z	1	Cotter Pin
	KIT 195015A	9	C49-3276-X-24	1	Chamber - Type 24
		5	43-X-1194	1	Clevis Pin
		6	K-237Z	1	Cotter Pin
	KIT 195015B	9	C39-3276-X-24	1	Chamber - Type 24
		5	43-X-1194	1	Clevis Pin
		6	K-237Z	1	Cotter Pin
	KIT 195016A	9	C2-3276-T-20	1	Chamber - Type 20/24
		5	43-X-1194	1	Clevis Pin
		6	K-237Z	1	Cotter Pin
	KIT 195017A	9	C40-3276-X-14	1	Chamber - Type 24/24
		5	43-X-1194	1	Clevis Pin
		6	K-237Z	1	Cotter Pin
	KIT 195017B	9	C46-3276-X-24	1	Chamber - Type 24/24
		5	43-X-1194	1	Clevis Pin
		6	K-237Z	1	Cotter Pin
	KIT 195018A	9	C47-3276-X-24	1	Chamber - Type 24/30
		5	43-X-1194	1	Clevis Pin
		6	K-237Z	1	Cotter Pin
	KIT 195018B	9	C48-3276-X-24	1	Chamber - Type 24/30
		5	43-X-1194	1	Clevis Pin
		6	K-237Z	1	Cotter Pin
Saddle Bolt Kit	KIT 195011	11	41-X-1484	4	Saddle Bolt
		12	MWA-520P	4	Washer
Lever Kit	KIT 195003	13	3501-M-1183	1	Lever
		14	MS-208050Z-1	1	Bolt

DX195 Rotors

Figure 2 - Rotor

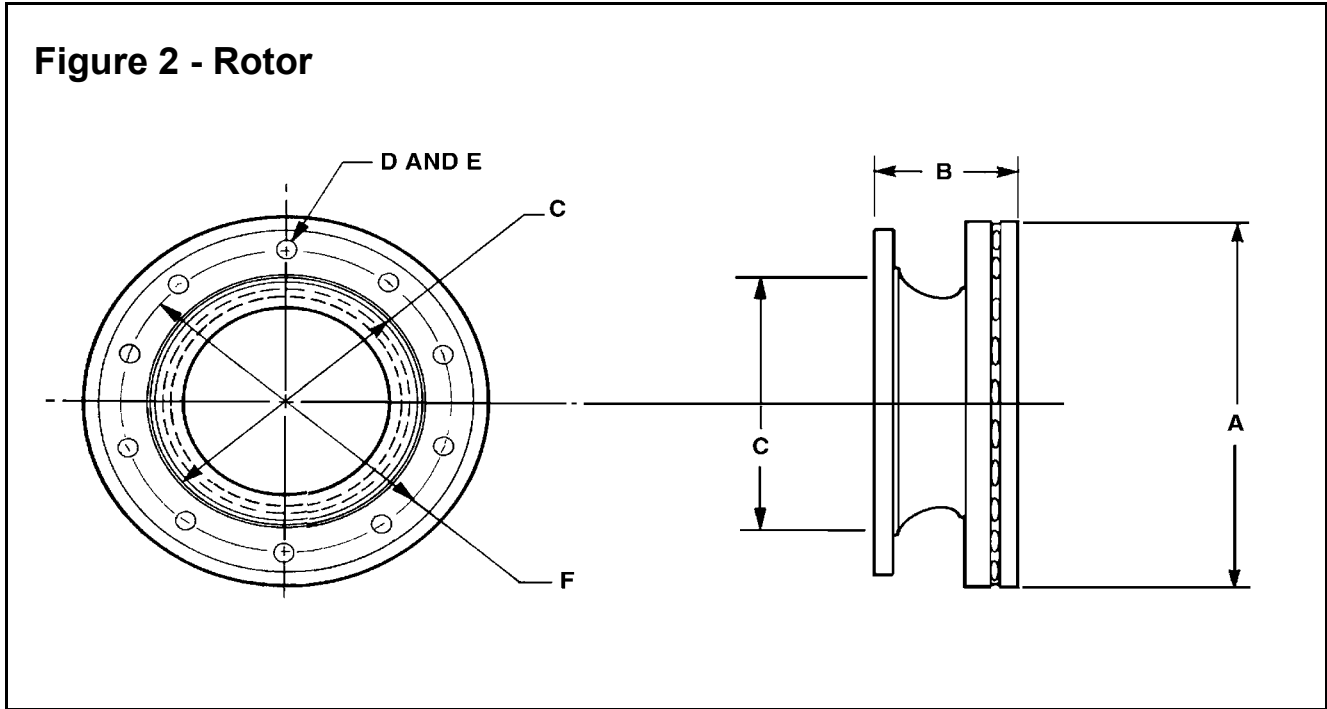

DX195 Rotors – Figure 2

Part Number	DX195	A	B	C	D & E	F
3218-K-1415	Rotor 8 Stud U Section	378 mm [14.82 in]	156 mm [6.14 in]	216 mm [8.5 in]	8 holes x 27 mm [1.06 in]	275 mm [10.8 in]
3218-N-1366	Rotor 10 Stud U Section	378 mm [14.82 in]	156 mm [6.14 in]	216 mm [8.5 in]	10 holes x 32 mm [1.25 in]	286 mm [11.25 in]

Hubs & Wheel Studs (studs are separate as they also retain the rotor)

8 Stud FF Hub	A-333-T-4310
10 Stud FF Hub	A-333-M-4277
Wheel Stud (8 Stud Hub)	20-X-2474
Wheel Stud (10 Stud Hub)	20-X-2282

Figure 3 - DX225 Caliper Assembly

DX-225-21-1001K shown
DX-225-21-1002K opposite

Note: Caliper assy. kit excludes
items 1,2,5,6,9,11,12

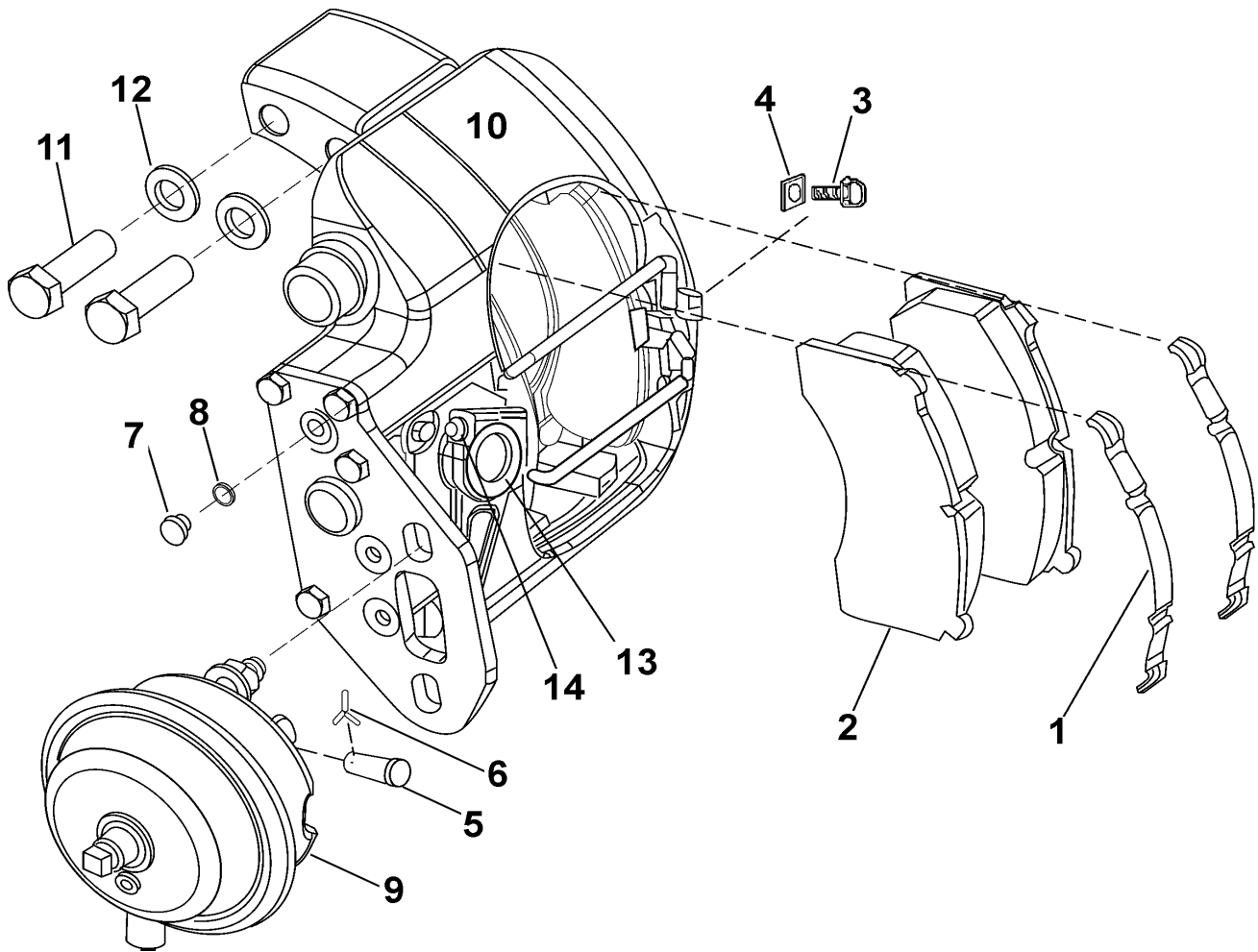

DX225 Caliper Service Kits – Figure 3

Kit Description	Aftermarket Kit	Item No.	OE Part Number	Qty. per Kit	Part Description
Pad Kit (R702)	KIT 225010	1	2258-C-1303	2	Spring
		2	A1-3222-A-2367	2	R702 Pad
		4	10-X-1556	1	Bolt
Stabilizing Bar Bolt Kit	KIT 225012	3	42-X-1040	1	Retaining Washer
		4	10-X-1556	1	Bolt
Clevis Pin Kit	KIT 195013	5	43-X-1194	1	Clevis Pin
		6	K-237Z	1	Cotter Pin
Caliper Assembly Kit	DX-225-21-1001K	10	DX-225-21-1001K	1	Caliper
		3	42-X-1040	1	Retaining Washer
		4	10-X-1556	1	Bolt
Caliper Assembly Kit	DX-225-21-1002K	10	DX-225-21-1002K	1	Caliper
		3	42-X-1040	1	Retaining Washer
		4	10-X-1556	1	Bolt
Plug Kit	KIT 195005	7	1250-R-1006	1	Plug
		8	1229-V-4468	1	Washer
Air Chamber Kit Part numbers based on type of chamber used on the axle.	KIT 195006	9	V89-3276-P-16	1	Chamber - Type 16
		5	43-X-1194	1	Clevis Pin
		6	K-237Z	1	Cotter Pin
	KIT 195014	9	V87-3276-T-20	1	Chamber - Type 20
		5	43-X-1194	1	Clevis Pin
		6	K-237Z	1	Cotter Pin
	KIT 195015A	9	C49-3276-X-24	1	Chamber - Type 24
		5	43-X-1194	1	Clevis Pin
		6	K-237Z	1	Cotter Pin
	KIT 195015B	9	C39-3276-X-24	1	Chamber - Type 24
		5	43-X-1194	1	Clevis Pin
		6	K-237Z	1	Cotter Pin
	KIT 195016A	9	C2-3276-T-20	1	Chamber - Type 20/24
		5	43-X-1194	1	Clevis Pin
		6	K-237Z	1	Cotter Pin
	KIT 195017A	9	C40-3276-X-14	1	Chamber - Type 24/24
		5	43-X-1194	1	Clevis Pin
		6	K-237Z	1	Cotter Pin
	KIT 195017B	9	C46-3276-X-24	1	Chamber - Type 24/24
		5	43-X-1194	1	Clevis Pin
		6	K-237Z	1	Cotter Pin
	KIT 195018A	9	C47-3276-X-24	1	Chamber - Type 24/30
		5	43-X-1194	1	Clevis Pin
		6	K-237Z	1	Cotter Pin
KIT 195018B	9	C48-3276-X-24	1	Chamber - Type 24/30	
	5	43-X-1194	1	Clevis Pin	
	6	K-237Z	1	Cotter Pin	
Saddle Bolt Kit	KIT 195011	11	41-X-1484	4	Saddle Bolt
		12	MWA-520P	4	Washer
Lever Kit	KIT 195003	13	3501-M-1183	1	Lever
		14	MS-208050Z-1	1	Bolt

DX225 Rotors

Figure 4 - Rotor Identity

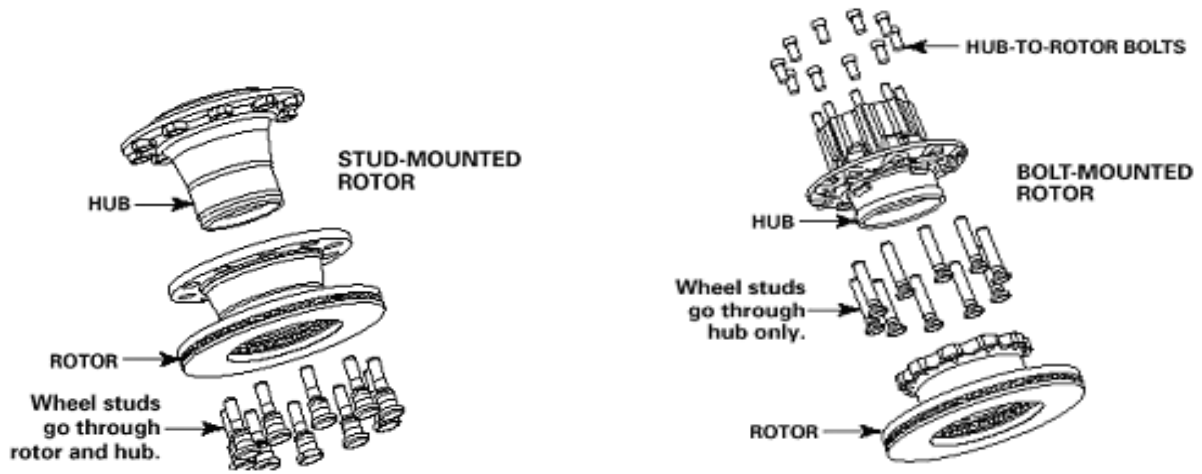

How to identify "Stud Mount" and "Bolt Mount" style rotors.

Figure 5 - Rotor

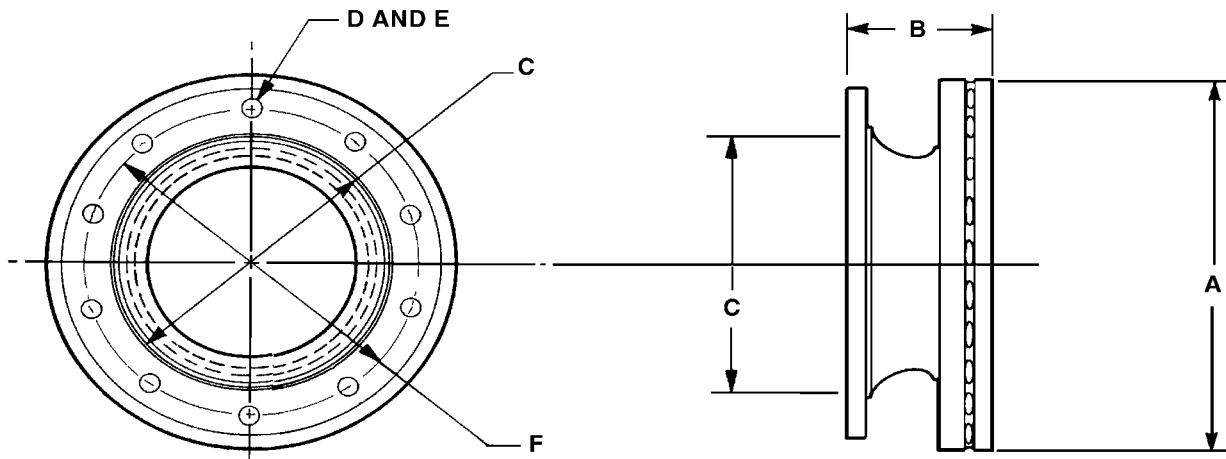

DX225 Rotors – Figure 4 and Figure 5

Part No.	DX225	A	B	C	D & E	F
3218-U-1425	Bolt Mount, 10 Wheel Studs	420 mm [16.5 in]	160 mm [6.3 in]	216 mm [8.5 in]	10 holes x 15.9 mm [0.63 in]	250 mm [9.8 in]
3218-K-1441	Stud Mount, 8 Wheel Studs	420 mm [16.5 in]	156 mm [6.14 in]	216 mm [8.5 in]	8 holes x 32 mm [1.25 in]	275 mm [10.8 in]
3218-T-1424	Stud Mount, 10 Wheel Studs	420 mm [16.5 in]	156 mm [6.14 in]	216 mm [8.5 in]	10 holes x 32 mm [1.25 in]	286 mm [11.25 in]

DX225 Rotor Mounting Bolt

Part No.	DX225	Quantity
15-X-1796	Rotor Mounting Bolt Only required for "Bolt Mount Rotors"	10 per Rotor

Front Hubs & Wheel Studs (studs are separate as they also retain the rotor)

8 Stud FF Hub	A-333-T-4310
10 Stud FF Hub	A-333-M-4277
Wheel Stud (8 Stud FF Hub)	20-X-2474
Wheel Stud (10 Stud FF Hub)	20-X-2282

Rear Hub Assemblies

10 Stud M22 x 3.227 Standout, with ABS	0415965001
10 Stud M22 x 2.527 Standout, with ABS	0415965002
10 Stud 3/4 x 16 UNF 1.34 Standout, with ABS	0415965003 RH 0415965004 LH
10 Stud M22 x 3.227 Standout, without ABS	0415965005
10 Stud M22 x 2.527 Standout, without ABS	0415965006
10 Stud 3/4 x 16 UNF 1.34 Standout, without ABS	0415965007 RH 0415965008 LH



Commercial Vehicle Aftermarket

Meritor Heavy Vehicle Systems, LLC
7975 Dixie Highway
Florence, KY 41042 USA
888-725-9355
www.arvinmeritor.com

Information contained in this publication was in effect at the time the publication was approved for printing and is subject to change without notice or liability. ArvinMeritor reserves the right to revise the information presented or discontinue the production of parts described at any time.

Copyright 2003
ArvinMeritor, Inc.

Printed in U.S.A.

Issued 9/03
PB-8857A